



RC8 4 TEAM KIT

RC8 4 TEAM KIT

#80947 RC8T4 Team Kit
#80948 RC8T4e Team Kit



1:18 Scale Nitro & Electric 4WD Off Road Competition Truggy Kit Manual



CHAMPIONS *by* DESIGN

www.associatedelec.com



:: Introduction

Thank you for purchasing this Team Associated product. This assembly manual contains instructions and tips for building and maintaining your new Kit. Please take a moment to read through this manual to help familiarize yourself with these steps. We are continually changing and improving our designs; therefore, actual parts may appear slightly different than in the illustrations. New parts will be noted on supplementary sheets located in the appropriate parts bags. Check each bag for these sheets before you start to build.

:: KIT Features

Features in the RC8T4 / T4e Kit:

- New gearboxes are specific to front and rear with larger bearing sizes resulting in longer life of ring and pinion gears: Front gearbox is a 3.5° inclined pinion gear angle to straighten the center driveshaft for increased drivetrain efficiency and reduced phasing and vibration. Rear gearbox is a 0° pinion gear angle and rear chassis brace mount
- Innovative front-end geometry with new 8° steering blocks are paired with a new wider upper suspension arm pivot for improved steering balance and predictable handling in all conditions
- New front and rear gearbox designs are engineered for better drivetrain efficiency with reduced phasing and vibration. Larger bearing sizes resulting in longer life of ring and pinion gears
- New front shock tower design with updated suspension geometry and body mount positions for all styles of truck bodies.
- Front lower and rear suspension arms have new material on rod ends and anti-roll bar links for improved durability.
- Front upper suspension arm updated to have bushing insert for improved fitment and performance.
- New rear wing mount has adjustable wing angle shims, significant strength improvements, an aerodynamic shape, and extra clearance for shock position adjustment
- The adjustable rear wing has more vertical fins for increased straight line stability, a taller rear lip height for increased downforce and increased strength in various areas to reduce bending fatigue
- New rear chassis brace is mounted centrally to the gearbox, which reduces material fatigue, centralizes shear forces, and improves the life of rear end drivetrain parts. There are three different chassis flex options using two chassis hole mounting locations and an optional turnbuckle ball for flex in more degrees of freedom
- New rear hub features symmetrical left and right common design with axle height inserts for adjustable roll center tuning options
- Front and rear center dogbone driveshafts for improved drivetrain efficiency and durability.
- +2° steering block arms
- V3 differentials with 46T ring and 10T pinion gears for improved gear ratios
- RC8T3.2 split center diff mounts with aluminum center top plate
- 16mm shocks equipped with improved material locking spring cups and rod ends, V2 springs, 'stiff' style shock bladder, combination bleeder/emulsion caps, and blue aluminum threaded collars
- RC8B3.2 narrow C and D arm mounts

RC8T4 Nitro Team Kit Features:

- Fuel tank with an ergonomically designed lid puller, high capacity, quick reference fuel markings and 1-, 2-, and 3cc stackable volume inserts for volume adjustment at sanctioned events

RC8T4e Team Kit Features:

- New chassis layout featuring saddle pack style battery configurations. Both configurations include a centrally mounted center differential and in-line center driveshafts for superior drivetrain efficiency and equalized chassis balance.
- Battery configurations are: Two 2s shorty or full size "saddle pack" for lowest CG and exceptional weight bias or one 4s shorty or full size simplified setup and more centralized weight bias

:: Additional

Your new RC8T4 / T4e comes as a kit. There are some items you will need to complete your kit (refer to website for suggestions):

- | | |
|---|---------------------------------|
| • 4.8-7.4v receiver battery (Flat style NiMH, Flat style LiPo, Flat style LiFe) | • Transmitter batteries |
| • 2 or 3 channel radio/transmitter set with switch (2.4GHz recommended) | • Throttle and Steering servos |
| • Polycarbonate body and specific paint | • Reamer / hole punch - (#1499) |
| • Model car fuel (20-30% nitro recommended) | • Glow igniter - (#27377) |
| • .21 class rear exhaust engine | • Fuel bottle - (#1747) |
| • CA (cyanoacrylic) glue - (#1597) | • Hobby knife |
| • Thread-locking compound - (#1596) | • Ride height gauge |

:: Other Helpful Items

- | | |
|---|---------------------------------|
| • Silicone Shock/Diff Fluids (Refer to website for complete listings) | • Body Scissors (AE #1737) |
| • Shock Pliers - (#1681) | • FT Hex Wrenches - (#1518) |
| • Wire Cutters | • Calipers or a Precision Ruler |
| | • FT Nut Drivers - (#1519) |















Associated Electrics, Inc.
21062 Bake Parkway
Lake Forest, CA 92630

















Customer Service
Tel: 949.544.7500
Fax: 949.544.7501

:: Hardware - 1:1 Scale View







Flat Head (fhcs)

	2.5x6mm (4675)
	2.5x8mm (31448)
	3x5mm (31540)
	3x6mm (31541)
	3x8mm (25201)
	3x10mm (25202)
	3x12mm (25203)
	3x14mm (89208)
	3x30mm (89212)
	4x10mm (81262)
	4x12mm (89214)
	4x14mm (89217)
	4x16mm (81263)
	4x20mm (81264)





Button Head (bhcs)

	2.5x6mm (31520)
	2.5x8mm (31521)
	2.5x18mm (81259)
	3x6mm (31531)
	3x8mm (31532)
	3x10mm (25211)
	3x12mm (89202)
	3x14mm (25187)
	3x16mm (89203)
	3x18mm (2308)
	3x20mm (25188)
	3x22mm (25189)
	3x24mm (89204)
	4x14mm (81260)
	4x16mm (81261)





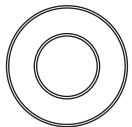
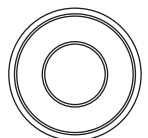

Set Screws

	3x3mm (25225)
	3x6mm (81257)
	3x10mm (4671)
	3x12mm (81258)
	4x4mm (7732)
	5x4mm (89221)





Ball Bearings

	5x8x2.5mm (8680)
	5x10x4mm (91560)
	6x10mm (31404)
	6x13x5mm flanged (91559)
	8x16x5mm (91564)
	8x16x5mm flanged (91565)







Socket Head (shcs)

	2x5mm (31511)
	2x16mm (7184)
	3x10mm (25620)
	3x12mm (89454)
	3x24mm (89225)
	3x26mm (89226)
	3x28mm (89227)

LP Socket Head (lp shcs)

	3x6mm (41089)
	3x10mm (41090)
	3x14mm (41094)
	3x16mm (41093)
	3x20mm (41091)

Nuts (lock/plain)

	M3 Nut (91477)
	M3 Alum. Locknut, Blue (31550)
	M3 Locknut, Black (25215)
	M3 Locknut w/Flange (25612)
	FT 3mm Locknuts, Blue(25392)
	FT M4 Locknut, Blue (31551)
	M4 Locknut, Serrated (91738)

:: Table of Contents

1..... Cover	16 - 18.....Rear End Build (Bags 7.1, 7.2, 7.3)
2..... Introduction	19 - 20.....Rear Hubs Build (Bag 8.1)
3..... 1:1 Hardware "Fold Out"	21 - 25.....Center Bulkhead Build (Bag 9.1)
4..... Table of Contents	25 - 26.....Linkages Build (Bag 10.1)
5 - 7.....Differentials Build (Bags 1.1, 1.2)	26 - 27.....Radio Tray Build (Bag 11.1)
7 - 8.....Shocks Build (Bag 2.1)	27 - 30.....Clutch / Filter Build (Bags 12.1, 12.2)
9.....Turnbuckles Build (Bags 3.1, 3.2)	30 - 31.....Fuel Tank Build (Bags 13.1, 13.2)
10 - 11.....Steering / Chassis Build (Bag 4.1)	31 - 32.....Wheels / Tires / Body (Misc.)
11 - 14.....Front Gearbox Build (Bags 5.1, 5.2, 5.3)	33..... Droop Settings
14 - 15.....Steering Blocks Build (Bags 6.1, 6.2)	30..... Back Cover

:: Notes



This symbol indicates a special note or instruction in the manual.



This symbol indicates a specific build order in the manual.



This symbol indicates a Racers Tip.



There is a 1:1 hardware foldout page in the front of the manual. To check the size of a part, line up your hardware with the correct drawing until you find the exact size. Each part in the foldout has a number assigned to it for ordering replacement parts.

**Associated Electrics, Inc.
21062 Bake Parkway
Lake Forest, CA 92630**



**Customer Service
Tel: 949.544.7500
Fax: 949.544.7501**

:: Differential Build (Front and Rear) - Bag 1.1, 1.2 - Step 1

#6588 black grease

81379 Diff Case

81385 Outdrive O-Ring 5.8x1.9mm

91564 8x16x5 Bearing

81008 15mm Outdrive (Front Diff)

81012 17mm Outdrive (Rear Diff)

81381 Diff Shim 6x8x0.20mm

#6588 black grease

81380 Pin 2.5x12mm

81380 Diff Sun Gear, 20T, HTC

Set aside 13x15.8mm shims until diff install

Align pin with groove in sun gear

:: Differential Build (Front and Rear) - Bag 1.1, 1.2 - Step 2

81381 x4 Diff Shim 3.6x12x0.12mm

81380 x4 Diff Planet Gear, 10T, HTC

81380 x2 Diff Crosspin

#6588 black grease

81385 Outdrive O-Ring 5.8x1.9mm

81014 Diff Ring Gear, 46T

91564 8x16x5 Bearing

81008 15mm Outdrive (Front Diff)

81012 17mm Outdrive (Rear Diff)

81381 Diff Shim 6x8x0.20mm

#6588 black grease

:: Differential Build (Front and Rear) - Bag 1.1, 1.2 - Step 3

81380 Pin 2.5x12mm

81380 Diff Sun Gear, 20T, HTC

81384 Diff Gasket

#6588 black grease

Racer's Tip:
Use black grease (#6588) to coat the back side of the diff gasket (i.e. not the entire gasket) before installation!

Align pin with groove in sun gear

:: Differential Build (Front and Rear) - Bag 1.1, 1.2 - Step 4



Racer's Tip:

Fill diff above the cross pins, below the planet gears as shown.

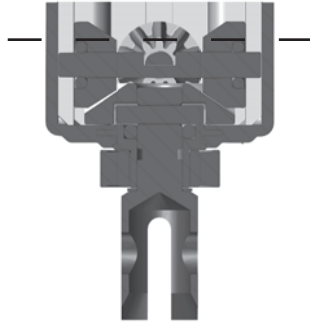

89208 $\times 4$
3x14mm
FHCS

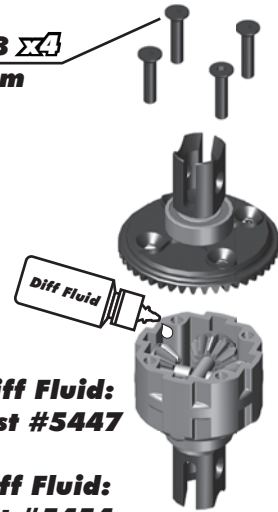

Front Diff Fluid:
15,000cst #5447

Rear Diff Fluid:
7,000cst #5454

:: Differential Build (Center) - Bag 1.1, 1.2 - Step 5



81379
Diff Case

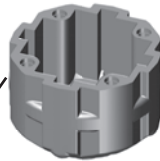

81385
Outdrive O-Ring
5.8x1.9mm

91564
8x16x5 Bearing



81381
Diff Shim
6x8x0.20mm



81008
15mm Outdrive, Center Diff



81380
Pin
2.5x12mm

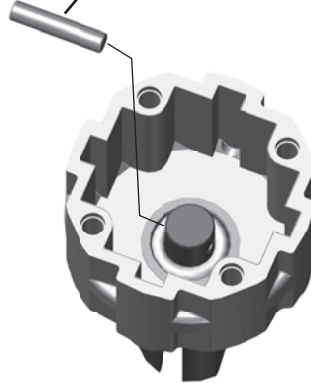

81380
Diff Sun Gear, 20T, HTC

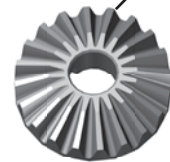

Align pin with groove in sun gear

:: Differential Build (Center) - Bag 1.1, 1.2 - Step 6

81381 $\times 4$
Diff Shim
3.6x12x0.12mm



81380 $\times 2$
Diff Crosspin

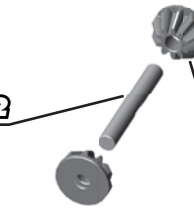

81380 $\times 4$
Diff Planet Gear, 10T, HTC

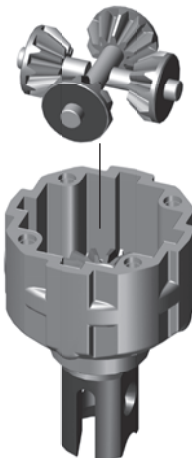
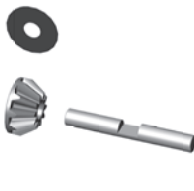

81389
Plastic Spur Gear, 46T



81386
Metal Spur Gear, 46T (Nitro shown)



81385
Outdrive O-Ring
5.8x1.9mm

91564
8x16x5 Bearing



81381
Diff Shim
6x8x0.20mm



81008
15mm Outdrive, Center Diff



:: Differential Build (Center) - Bag 1.1, 1.2 - Step 7

81380
Pin
2.5x12mm



81380
Diff Sun Gear, 20T, HTC



81384
Diff Gasket



#6588
black grease



Align pin with groove in sun gear

Racer's Tip:

Use black grease [#6588] to coat the back side of the diff gasket (i.e. not the entire gasket) before installation!

:: Differential Build (Center) - Bag 1.1, 1.2 - Step 8



Racer's Tip:

Fill diff above the cross pins, below the planet gears as shown.

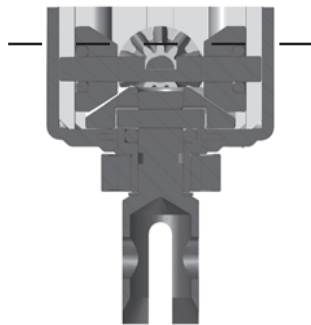

89208 
3x14mm
FHCS

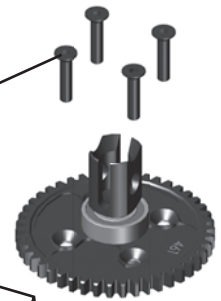

Diff Fluid

Center Diff Fluid:
15,000cst #5447

:: Shocks Build - Bag 2.1 - Step 1

81200
Shock Piston
(8x1.2 tapered)
Front and Rear

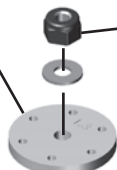

89215
2.5mm Shock Piston Locknut

89278 
2.6x6mm
Washer

81608
TiN Shock Shaft,
3.5x35.5mm
(Front)

81611
TiN Shock Shaft,
3.5x44.5mm
(Rear)



Install pistons taper down

81160
Shock Body,
30.5mm
(Front)



81161
Shock Body,
39.5mm
(Rear)

81185
Shock Body
O-Ring

81185
O-Ring Hat
Bushing

81188
Shock Body
Seal
Retainer

81186 
Shock
O-Ring

81185
O-Ring
Spacer

:: Shocks Build - Bag 2.1 - Step 2

Racer's Tip:
Use green slime (#1105) to lube the o-rings before installation!

81190 Shock Boots

81562 Rod End Ball

81512 Shock Rod End, +0 Front/Rear

81452 RC8B3.2 Shock Cap

81512 Shock Cap Insert

91492 2x4mm BHCS

91492 Gasket (2)

81453 Bladder, Stiff (1)

When installing the shock bladder, make sure it is correctly seated within the shock cap as shown.

:: Shocks Build - Bag 2.1 - Step 3

Fill to top of shock body.

Front Shock Fluid: 45wt #5430

Rear Shock Fluid: 40wt #5423

Leave a gap when installing the shock cap.

Compress shock shaft fully. Let shock fluid bleed from cap, then tighten cap.

For more rebound, do not compress shock shaft as far before tightening the shock cap.

:: Shocks Build - Bag 2.1 - Step 4

The springs come with a colored marking pre-installed for easy identification

81221 Spring Collar O-Ring, 20mm

81221 Spring Collar, 20mm

81226 V2 Front Spring, Yellow (5.70lb/in)

81237 V2 Rear Spring, Red (4.70lb/in)

81512 Spring Cup (1)

25211 3x10mm BHCS (2)

:: Turnbuckles Build - Bag 3.1 - Step 1

Electric Steering Servo Turnbuckle

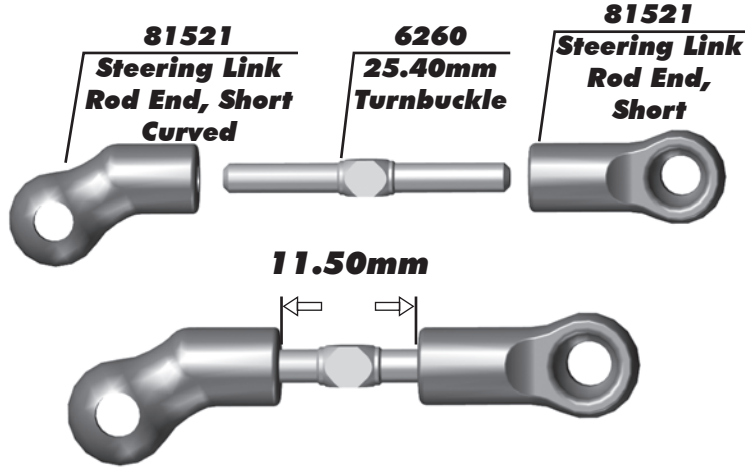

Nitro Steering Servo Turnbuckle

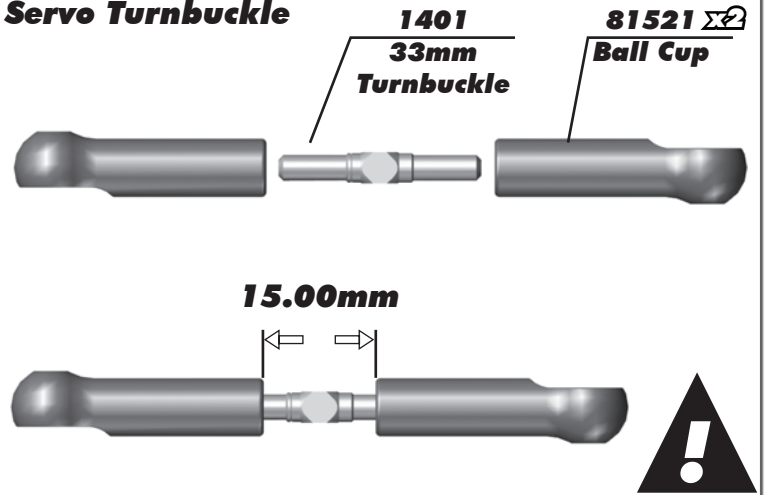

Set aside until page 22

:: Turnbuckles Build - Bag 3.1 - Step 2

Steering Turnbuckle

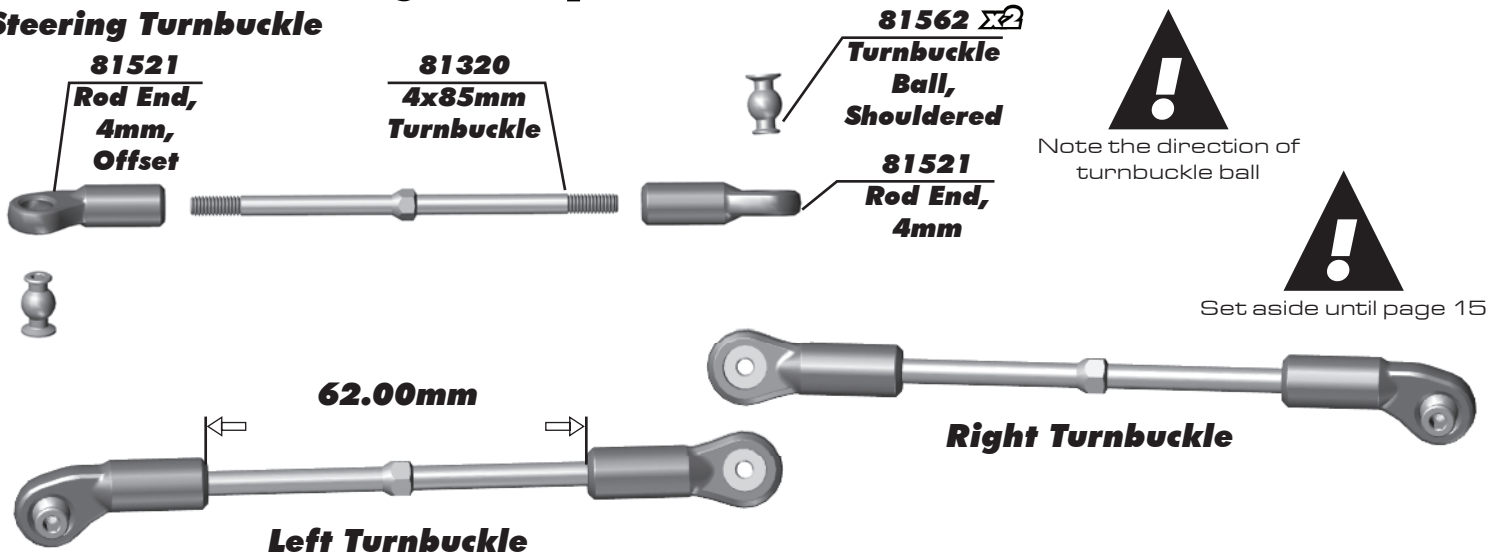

Set aside until page 15

:: Turnbuckles Build - Bag 3.1 - Step 3

Rear Hub Turnbuckle

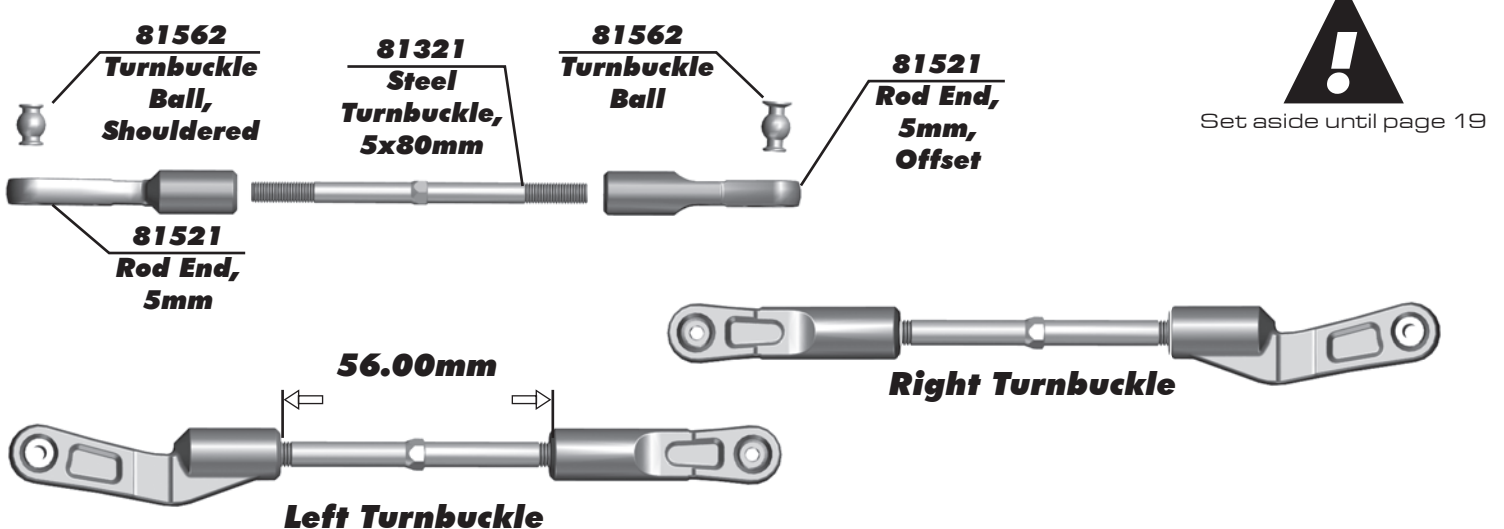

Set aside until page 19

:: Steering / Chassis Build - Bag 4.1 - Step 1

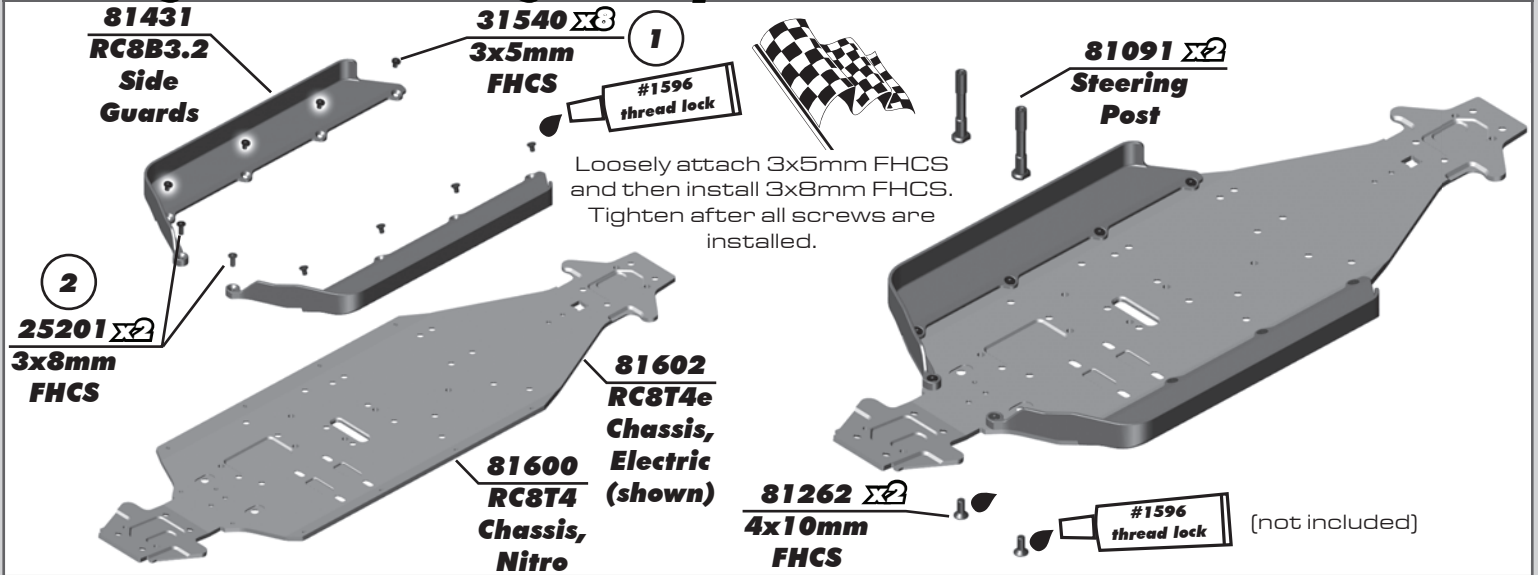

:: Steering / Chassis Build - Bag 4.1 - Step 2

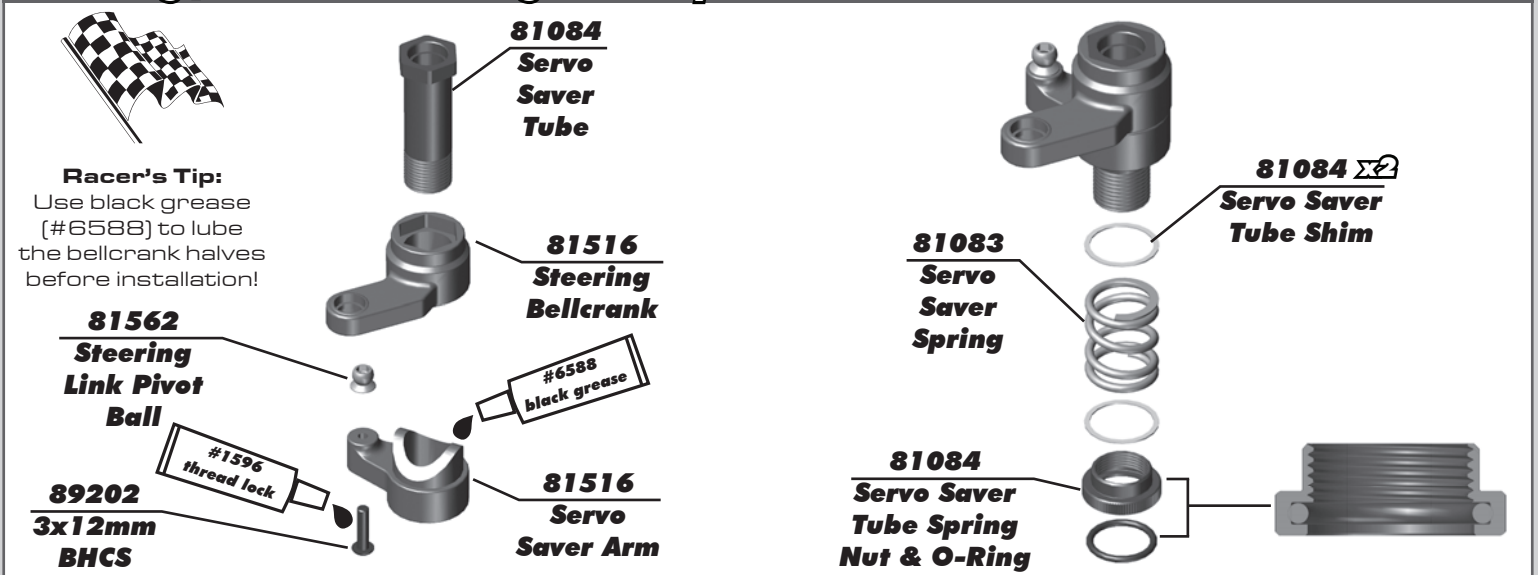

:: Steering / Chassis Build - Bag 4.1 - Step 3

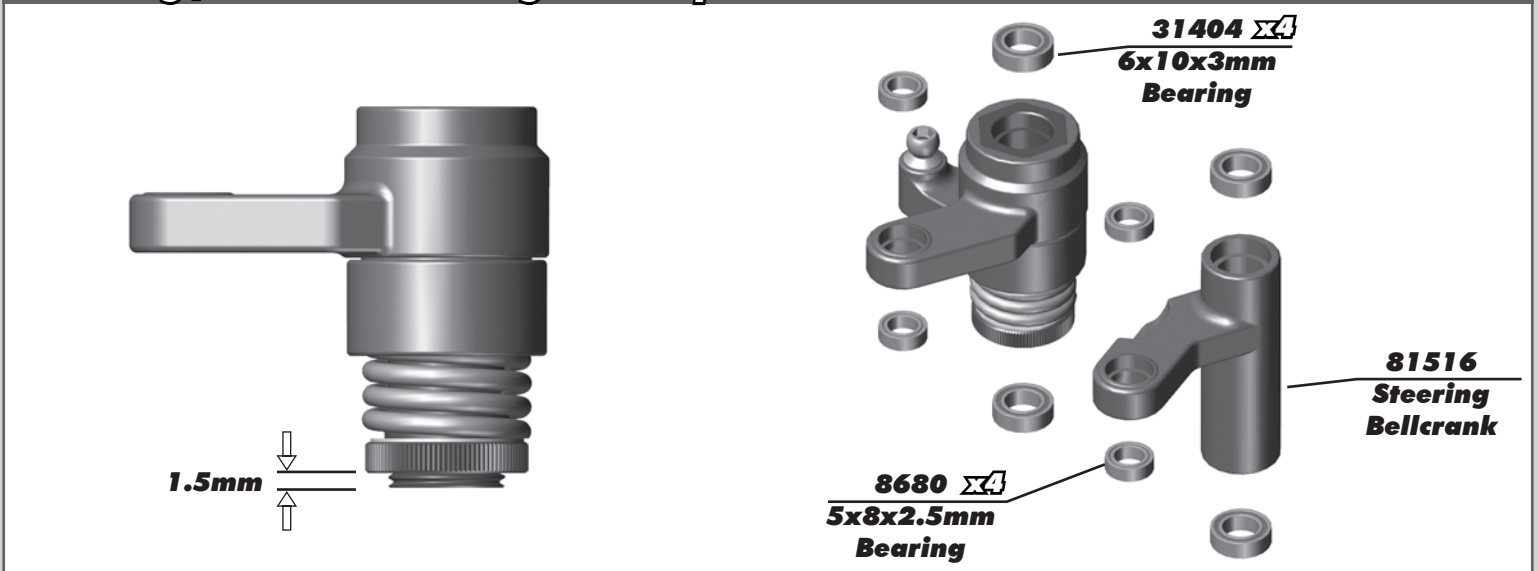

:: Steering / Chassis Build - Bag 4.1 - Step 4

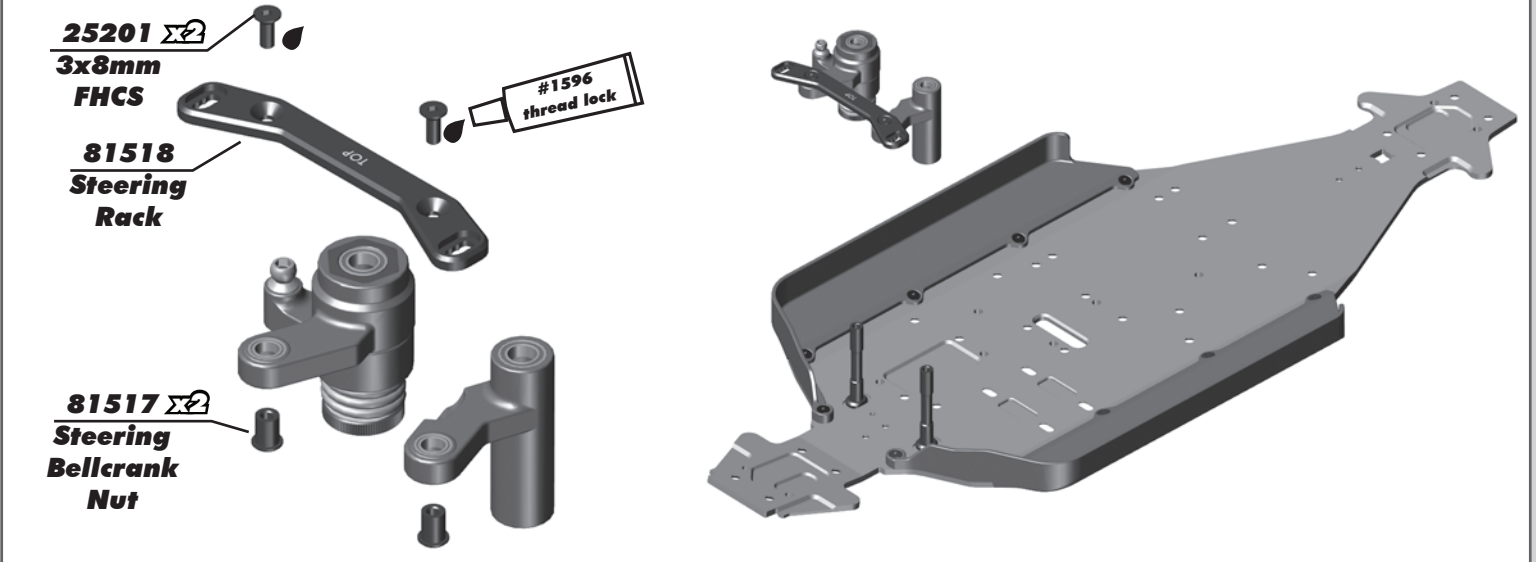

:: Front Gearbox Build - Bag 5.1, 5.2, 5.3 - Step 1

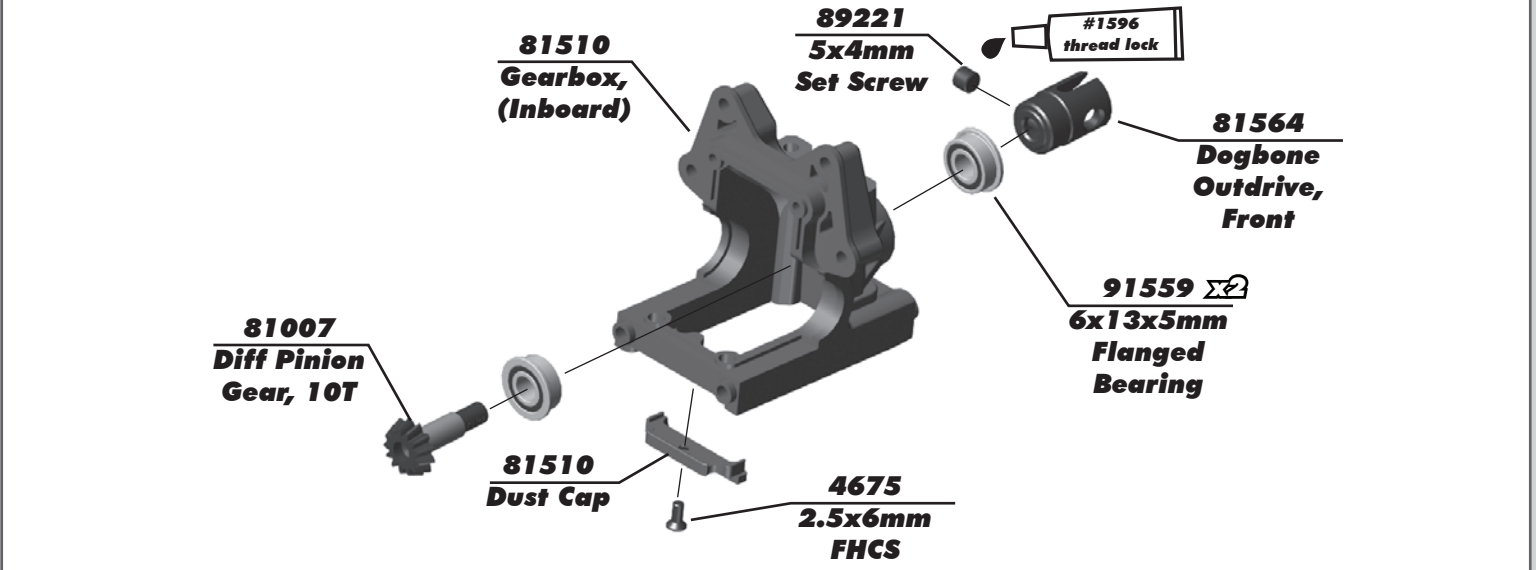

:: Front Gearbox Build - Bag 5.1, 5.2, 5.3 - Step 2

! Diff Install Note:
The diffs for nitro vs electric are installed in a different direction. Pictured is the T4e electric direction.

Rotate the diff 180 degrees for the T4 nitro kit.

81381 Diff Shim 13.5x15.8x0.20mm

81510 Anti-Roll Bar Cap

25620 3x10mm SHCS

81510 Gearbox, (Outboard)

! Nitro Direction

! STEP 1

! STEP 2

#6588 black grease

Step 1:
Add shims on the ring gear side to TIGHTEN gear mesh. Subtract shims on this side to LOOSEN gear mesh.
NOTE:
Start 1x Thick 0.2mm

Step 2:
Add or subtract shims here to finalize diff side to side play once gear mesh is set from Step 1.
Recommended diff "side-to-side" clearance [gearbox assembly] 0.10 - 0.25mm. Start with 1 x 0.1 mm.

Note:
0.1 mm shim can be used for fine tuning of gear mesh

:: Front Gearbox Build - Bag 5.1, 5.2, 5.3 - Step 3

Kit Setup:

Build left and right side!

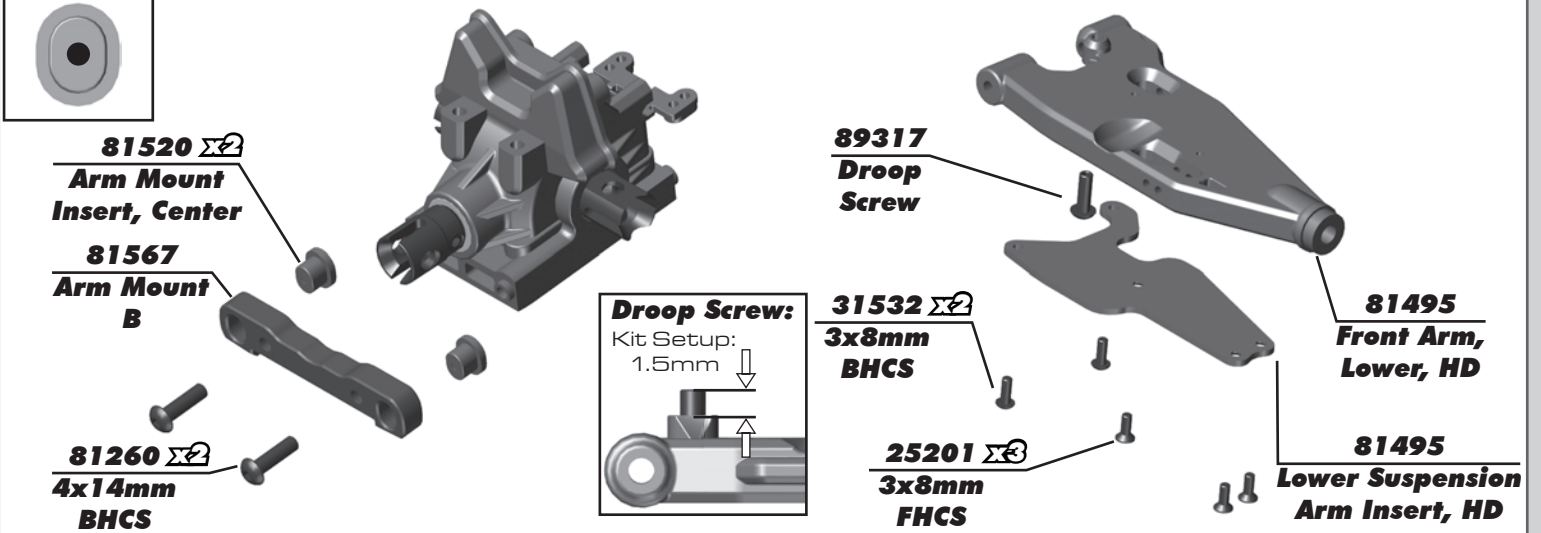

:: Front Gearbox Build - Bag 5.1, 5.2, 5.3 - Step 4

Kit Setup:

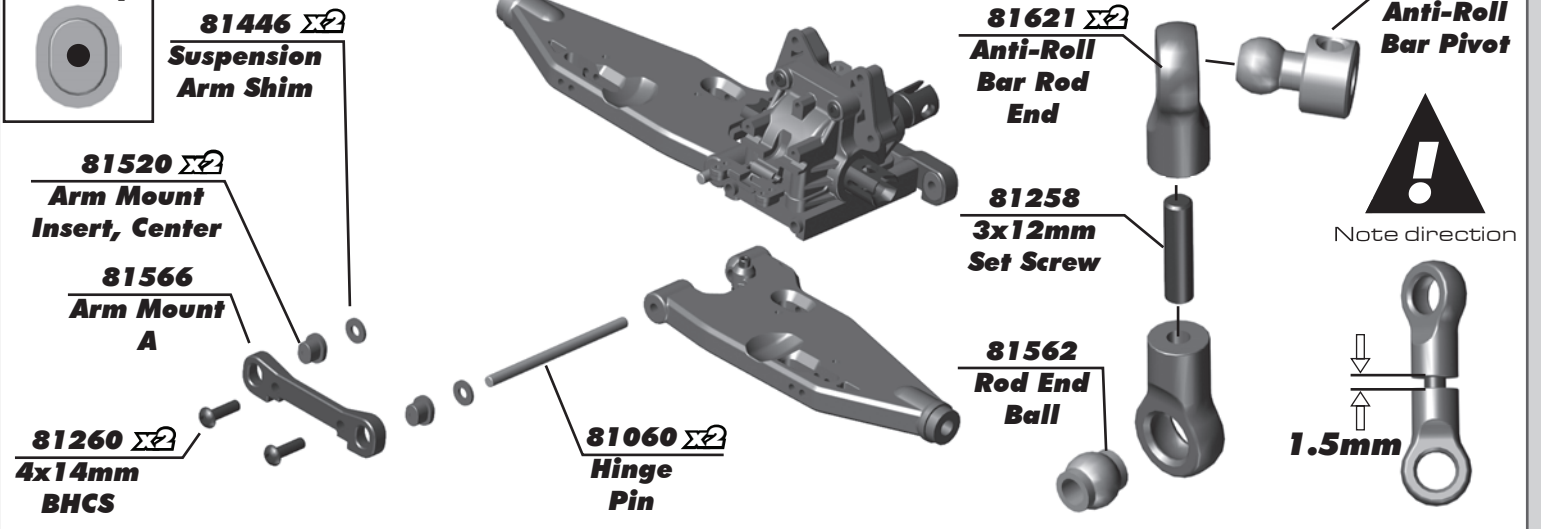

:: Front Gearbox Build - Bag 5.1, 5.2, 5.3 - Step 5

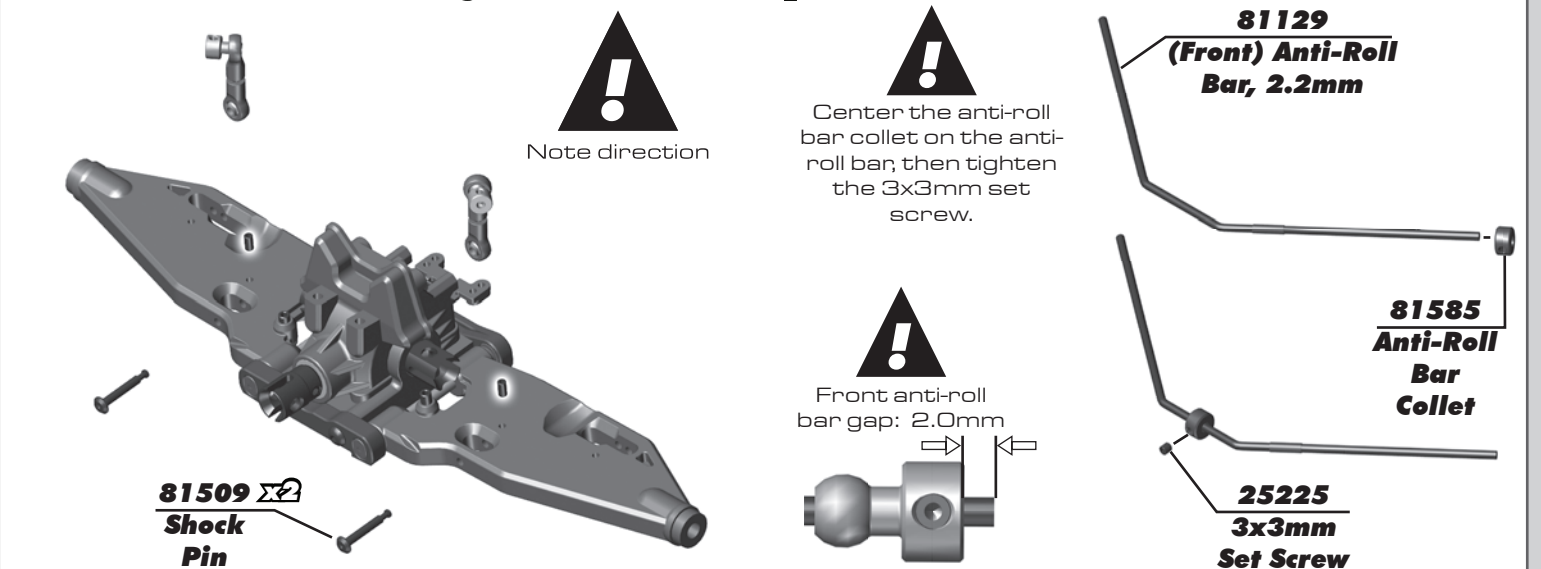

:: Front Gearbox Build - Bag 5.1, 5.2, 5.3 - Step 6



Tighten 3x6mm set screws just enough to still allow the anti-roll bar to move freely.

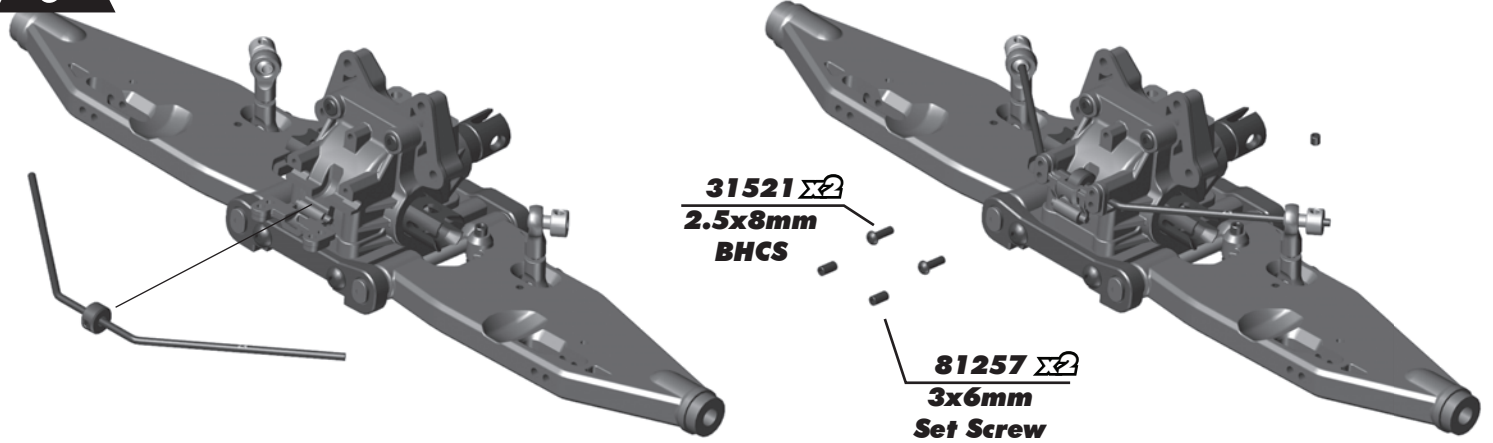

:: Front Gearbox Build - Bag 5.1, 5.2, 5.3 - Step 7

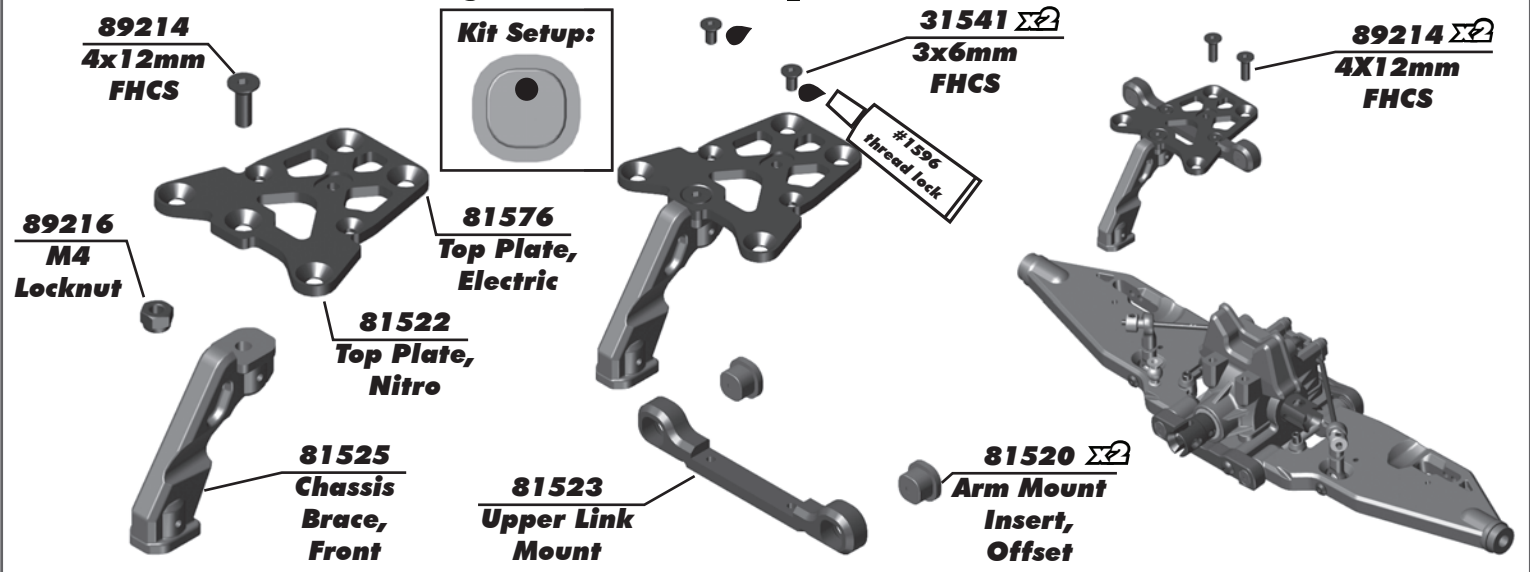

:: Front Gearbox Build - Bag 5.1, 5.2, 5.3 - Step 8

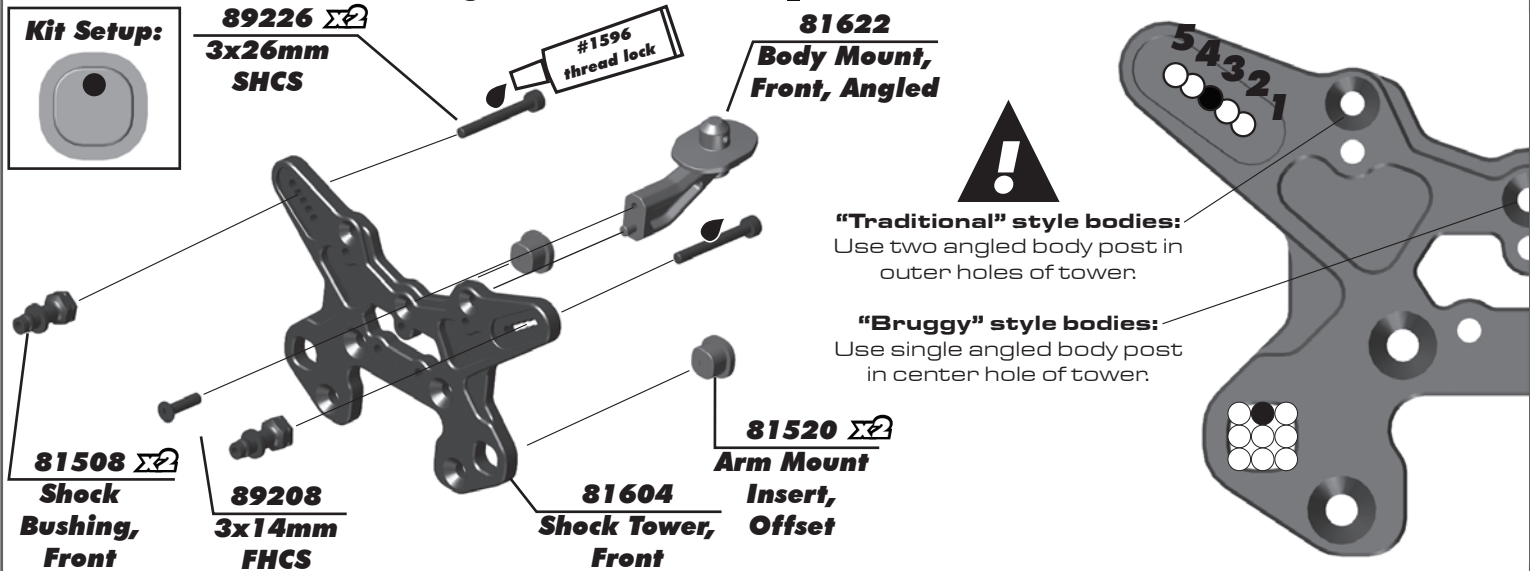

:: Front Gearbox Build - Bag 5.1, 5.2, 5.3 - Step 9

Build left and right side!

Kit setup is zero caster clips behind upper suspension arm. Adjusting final arm spacing to have a tight fit and freely rotating arm is done by adding shims to the front of the arm. Start with a 1 mm caster clip.

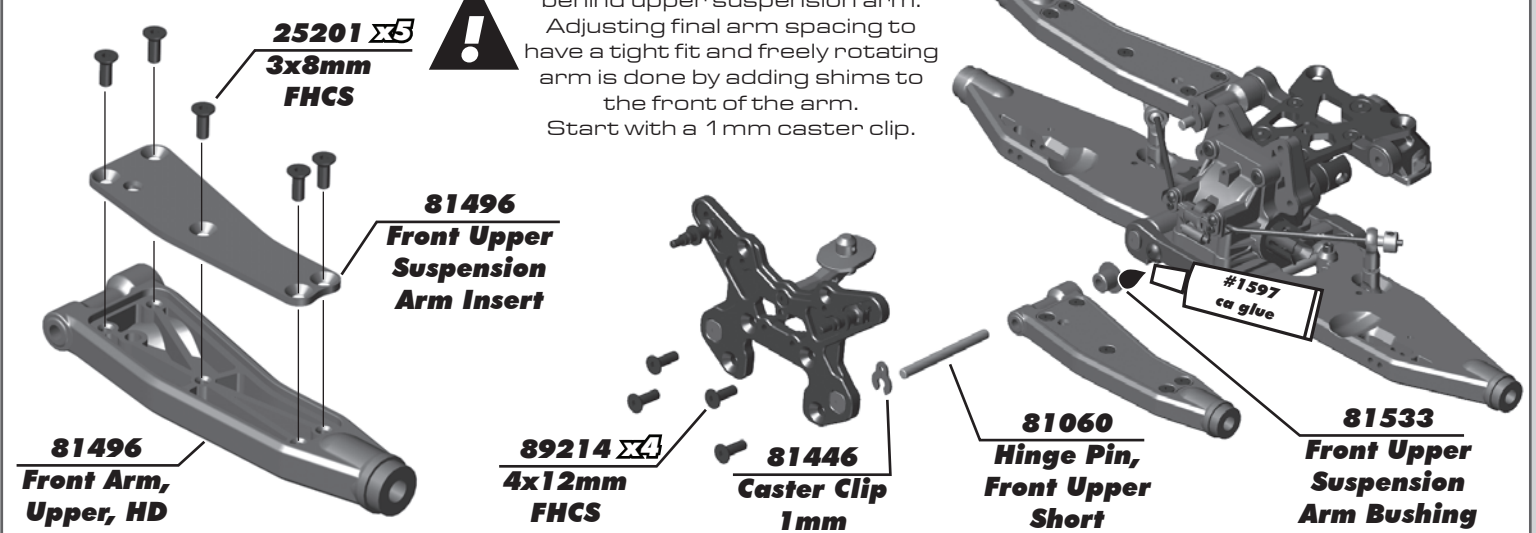

:: Steering Blocks Build - Bag 6.1 - Step 1

Build left and right side!

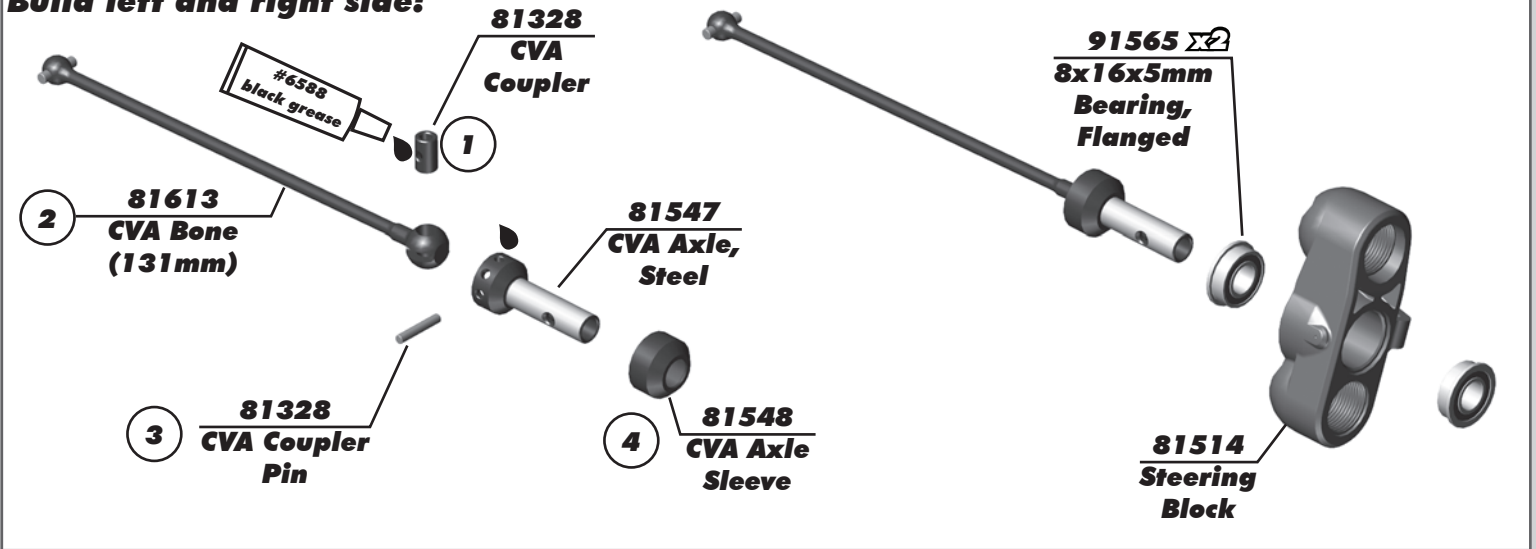

:: Steering Blocks Build - Bag 6.1 - Step 2

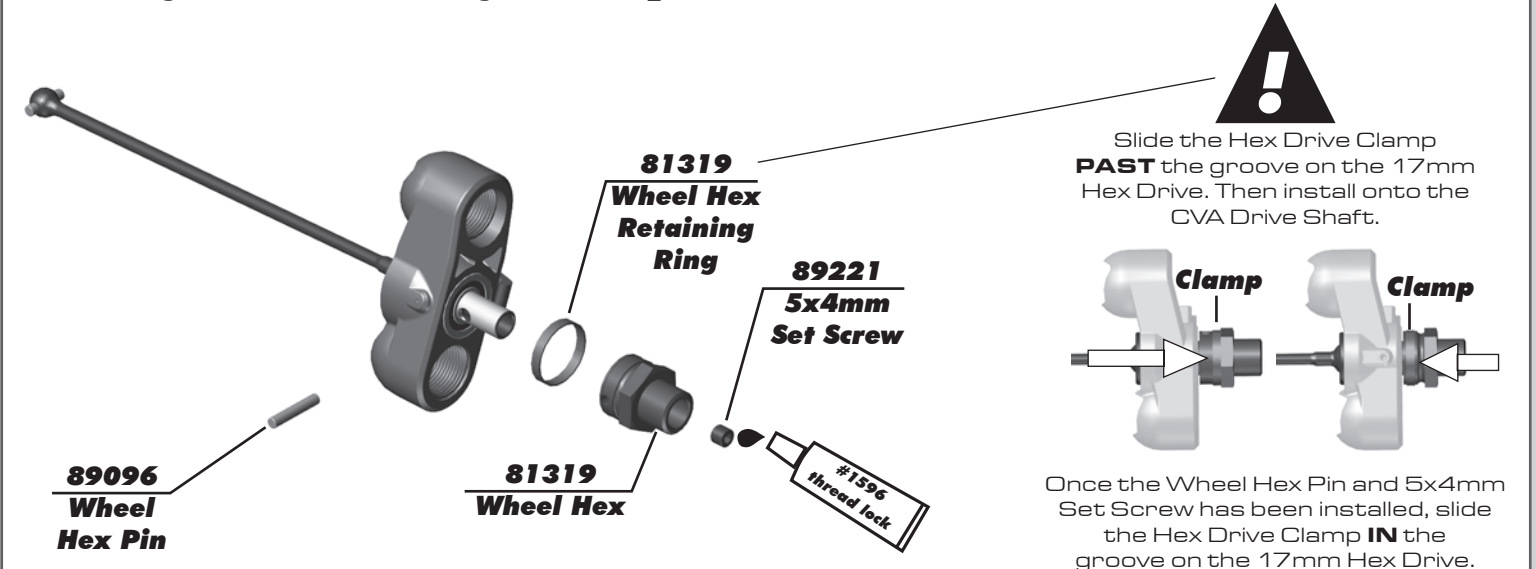

:: Steering Blocks Build - Bag 6.1 - Step 3

Build left and right side!

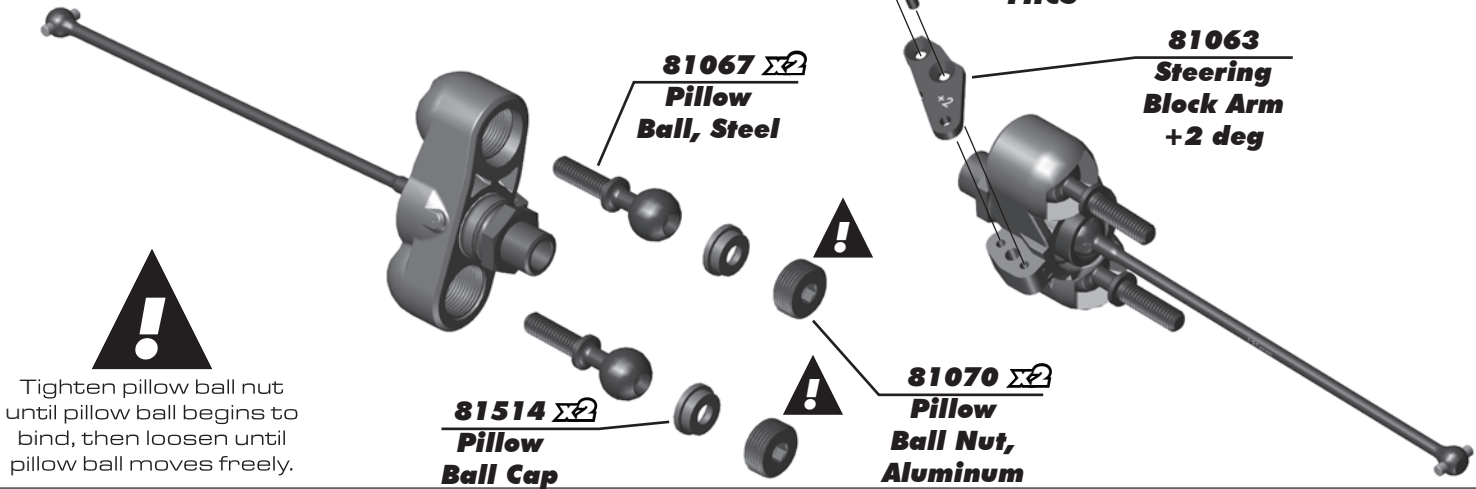

:: Steering Blocks Build - Bag 6.1 - Step 4

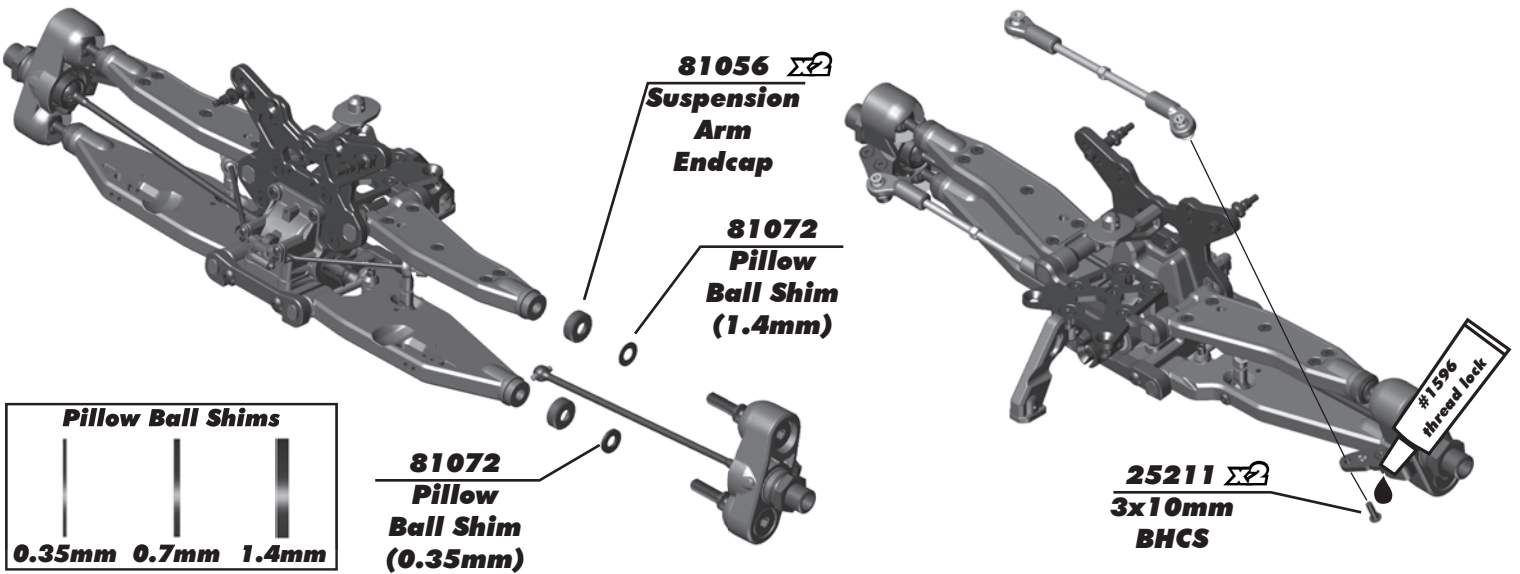

:: Steering Blocks Build - Bag 6.1 - Step 5

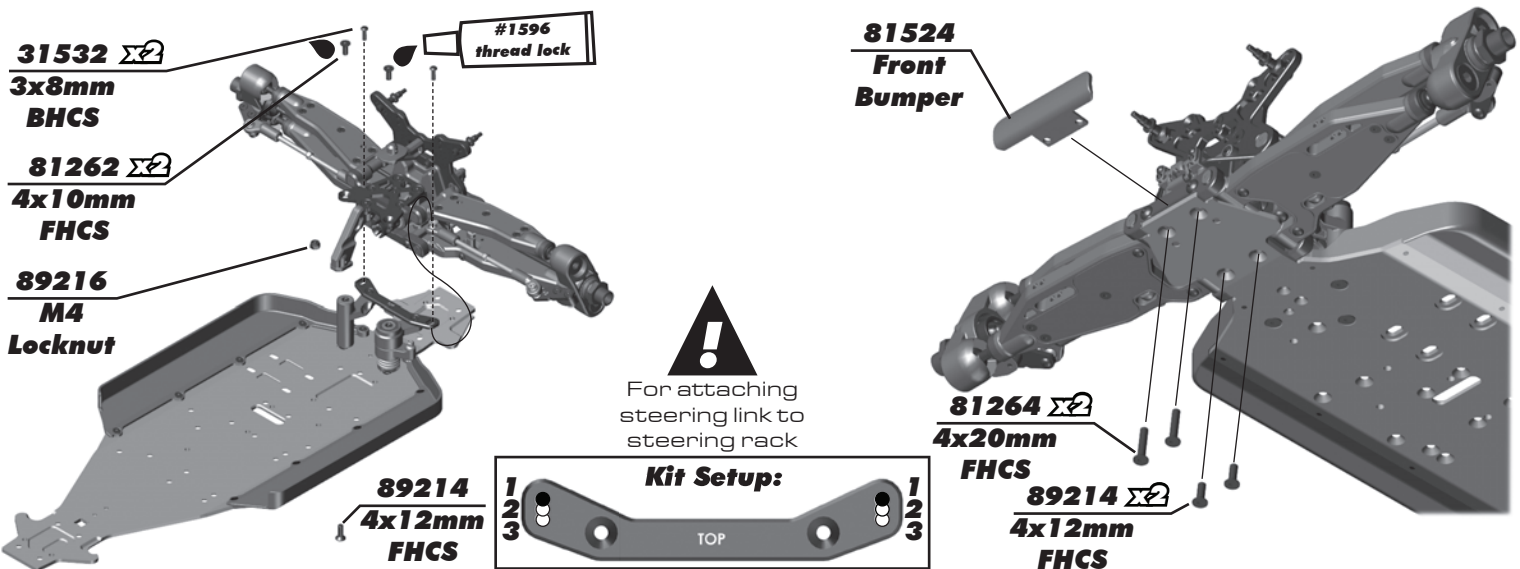

:: Rear End Build - Bag 7.1, 7.2, 7.3 - Step 1

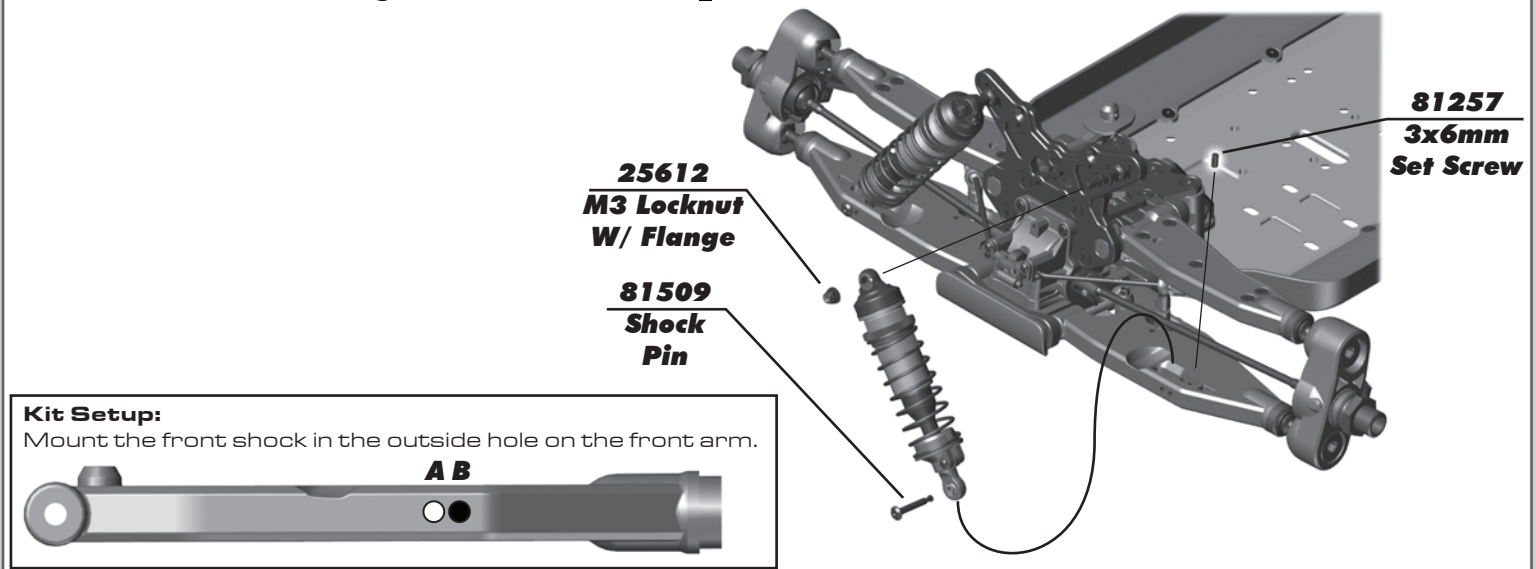

:: Rear End Build - Bag 7.1, 7.2, 7.3 - Step 1

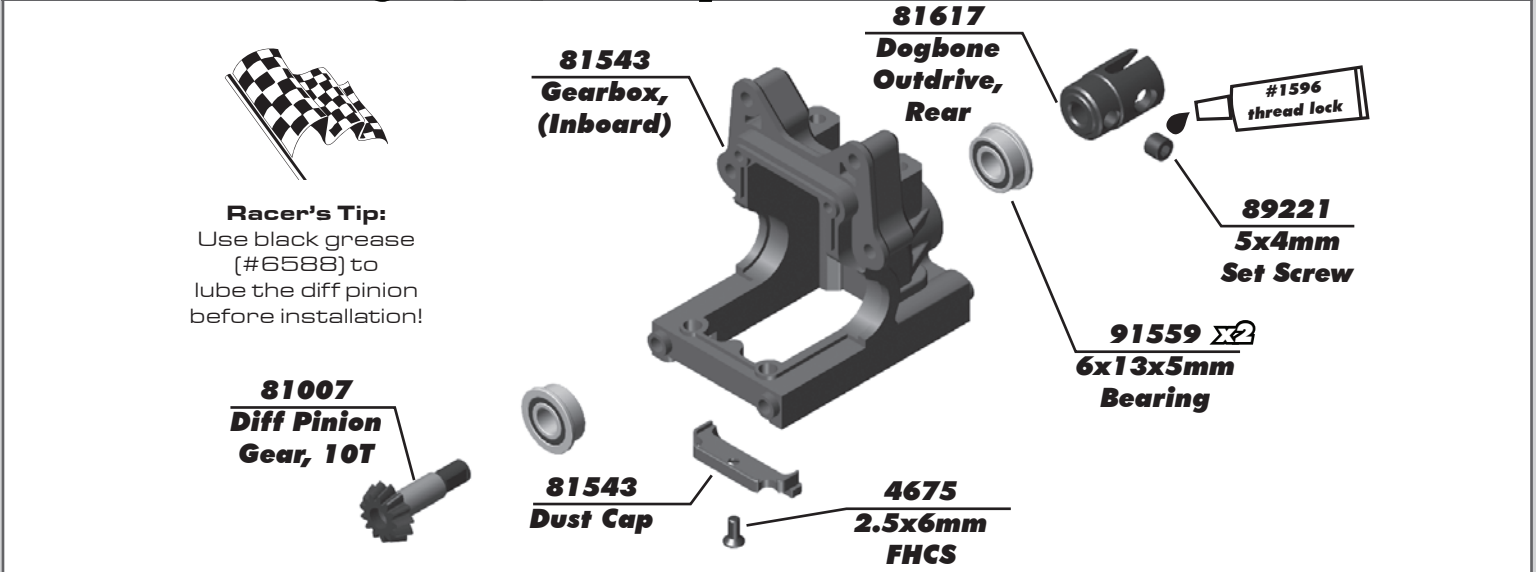

:: Rear End Build - Bag 7.1, 7.2, 7.3 - Step 2

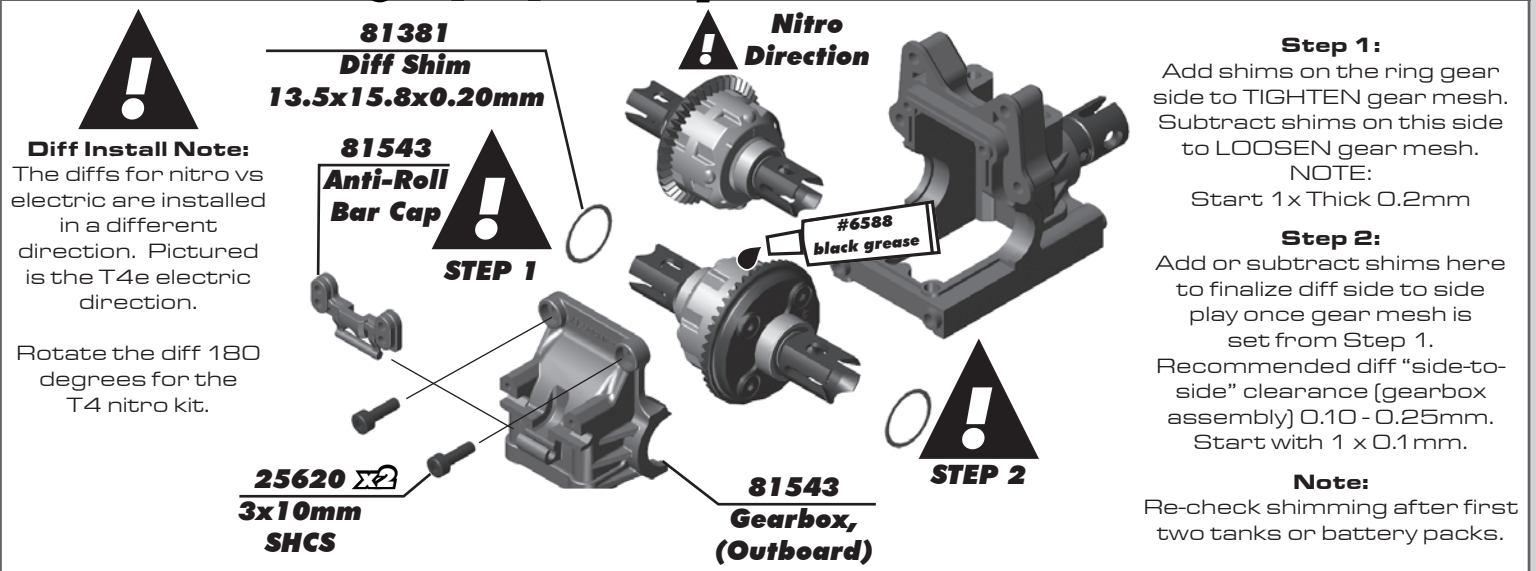

:: Rear End Build - Bag 7.1, 7.2, 7.3 - Step 3

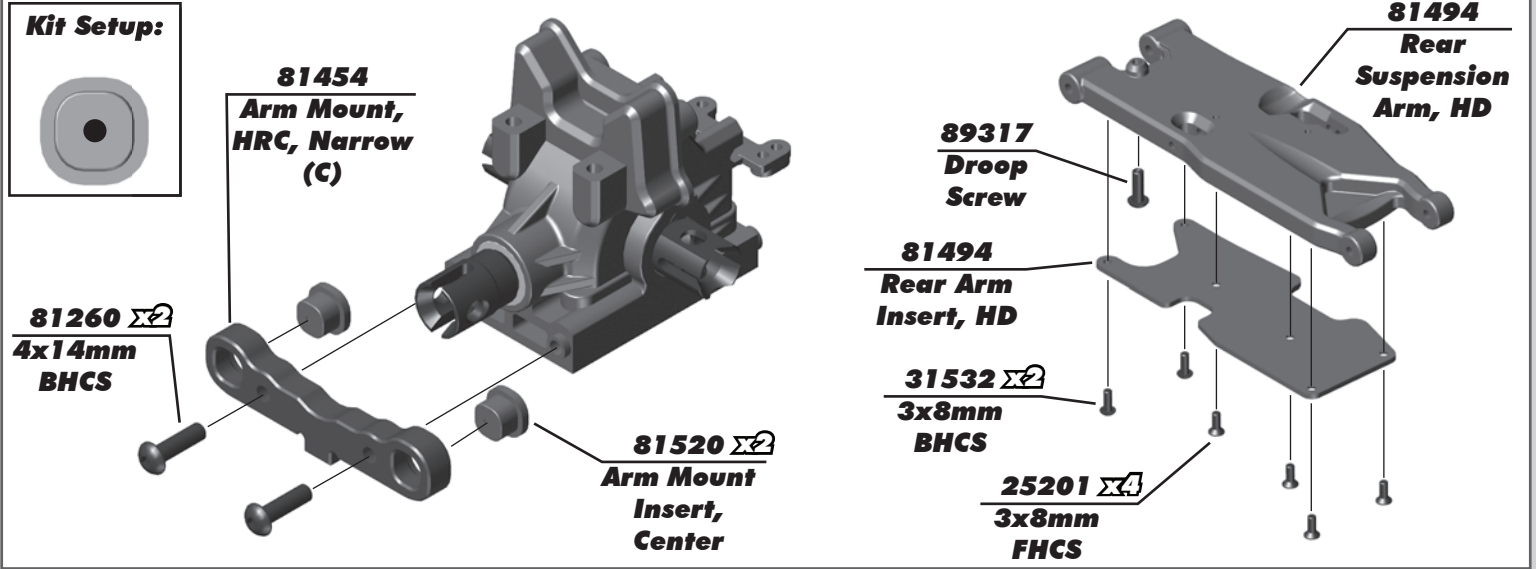

:: Rear End Build - Bag 7.1, 7.2, 7.3 - Step 4

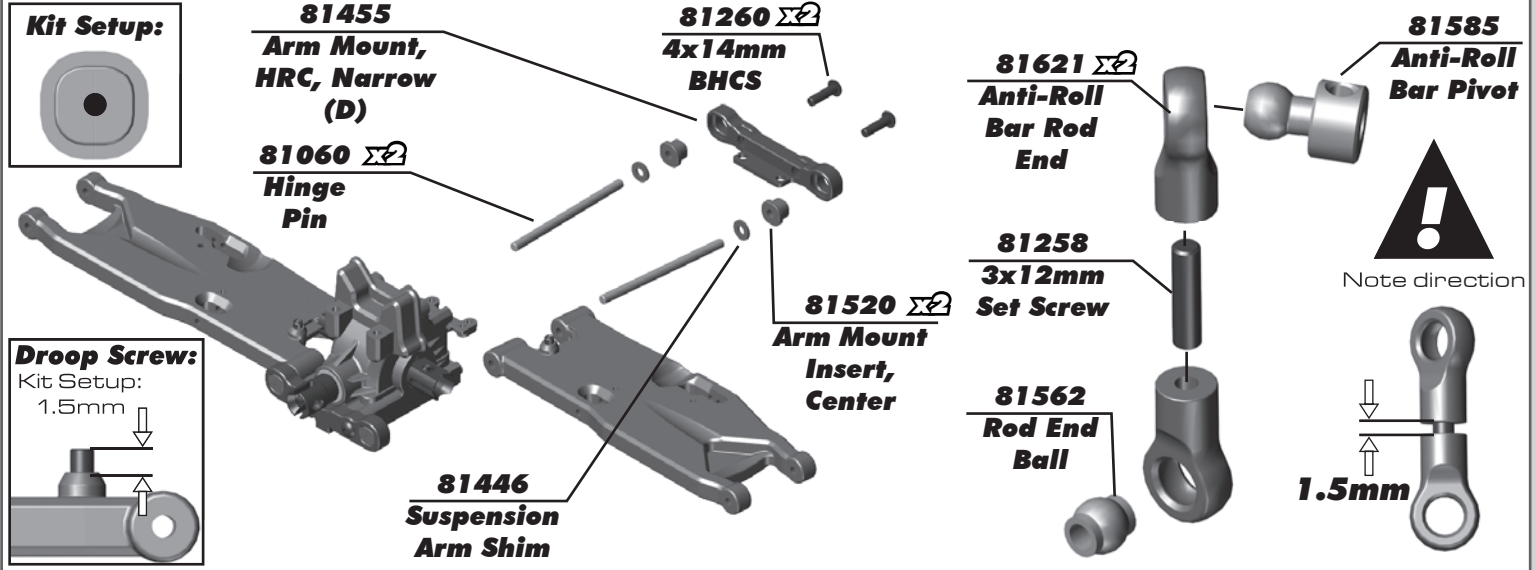

:: Rear End Build - Bag 7.1, 7.2, 7.3 - Step 5

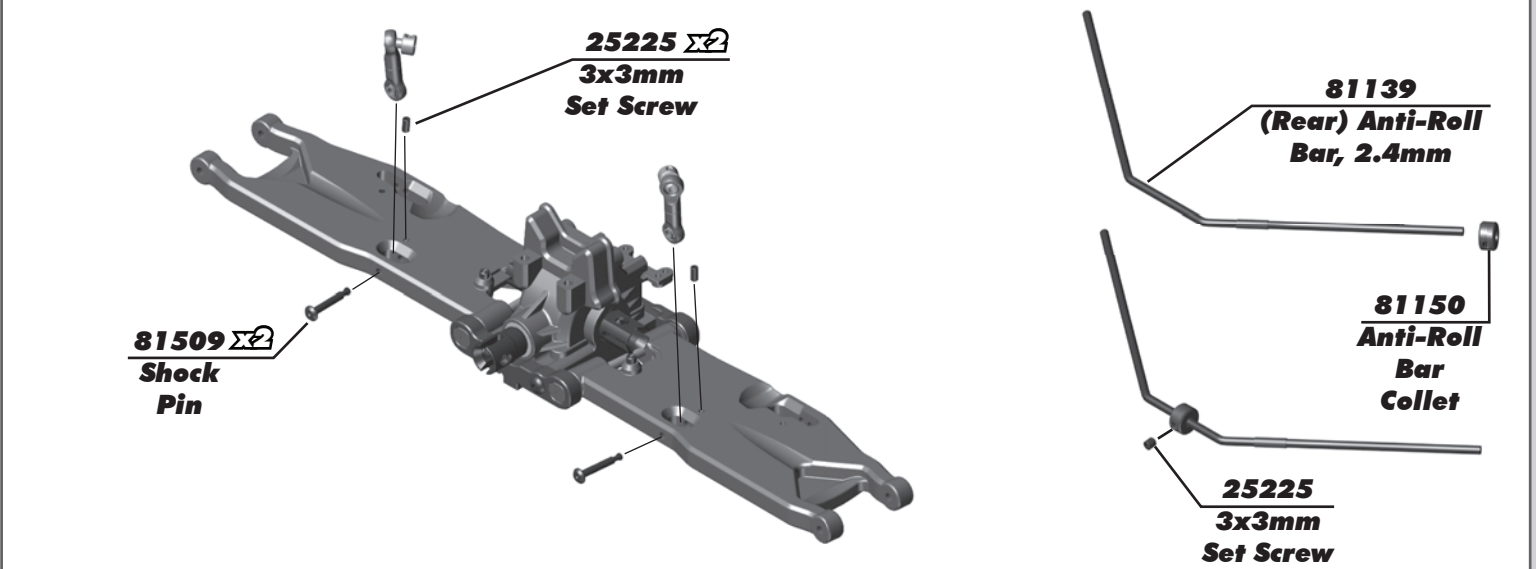

:: Rear End Build - Bag 7.1, 7.2, 7.3 - Step 6

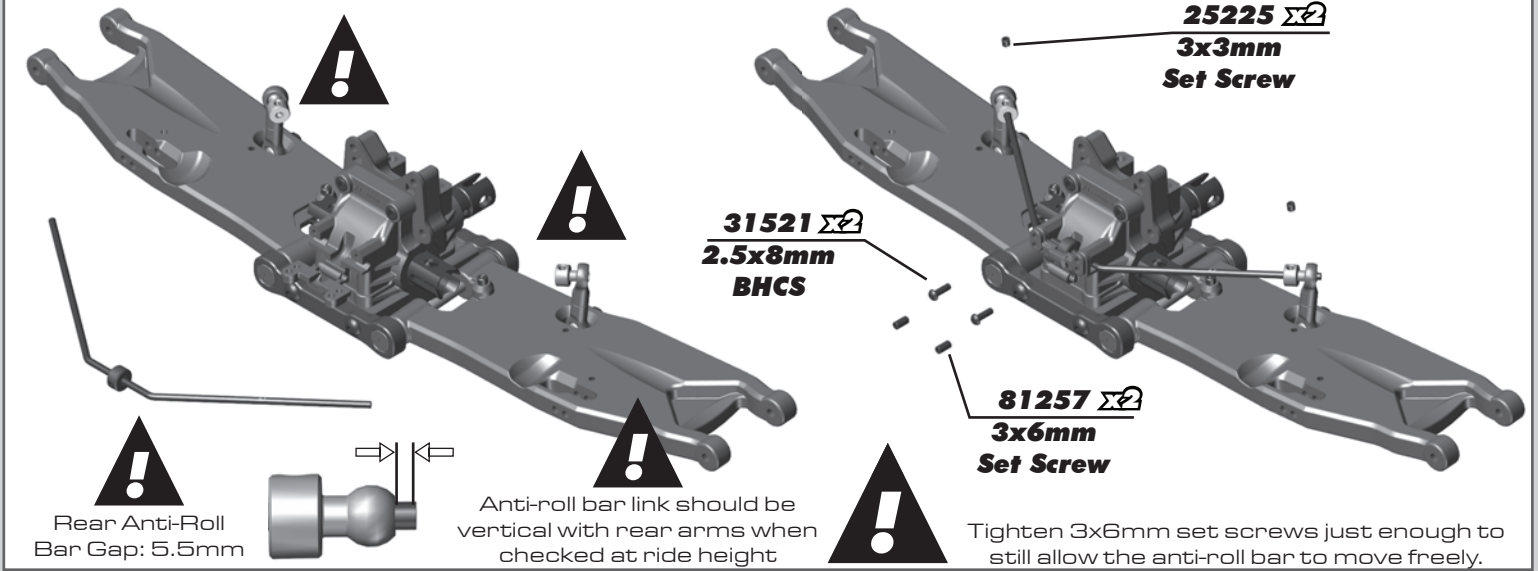

:: Rear End Build - Bag 7.1, 7.2, 7.3 - Step 7

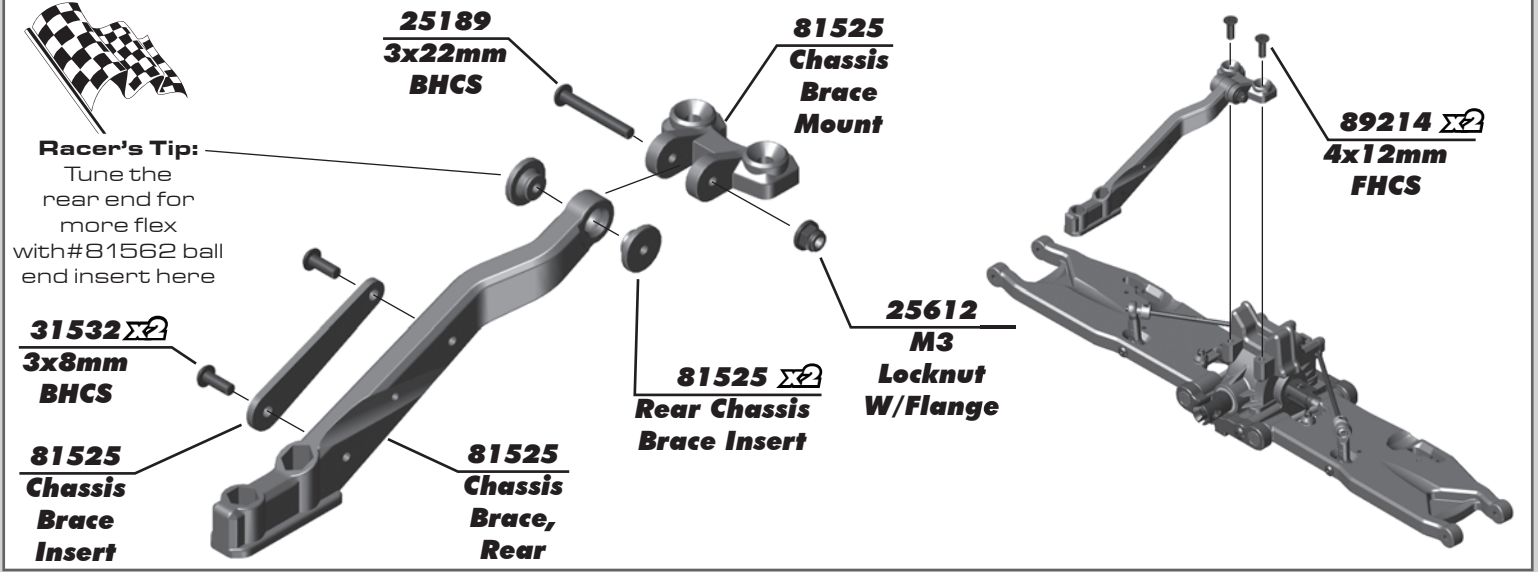

:: Rear End Build - Bag 7.1, 7.2, 7.3 - Step 8

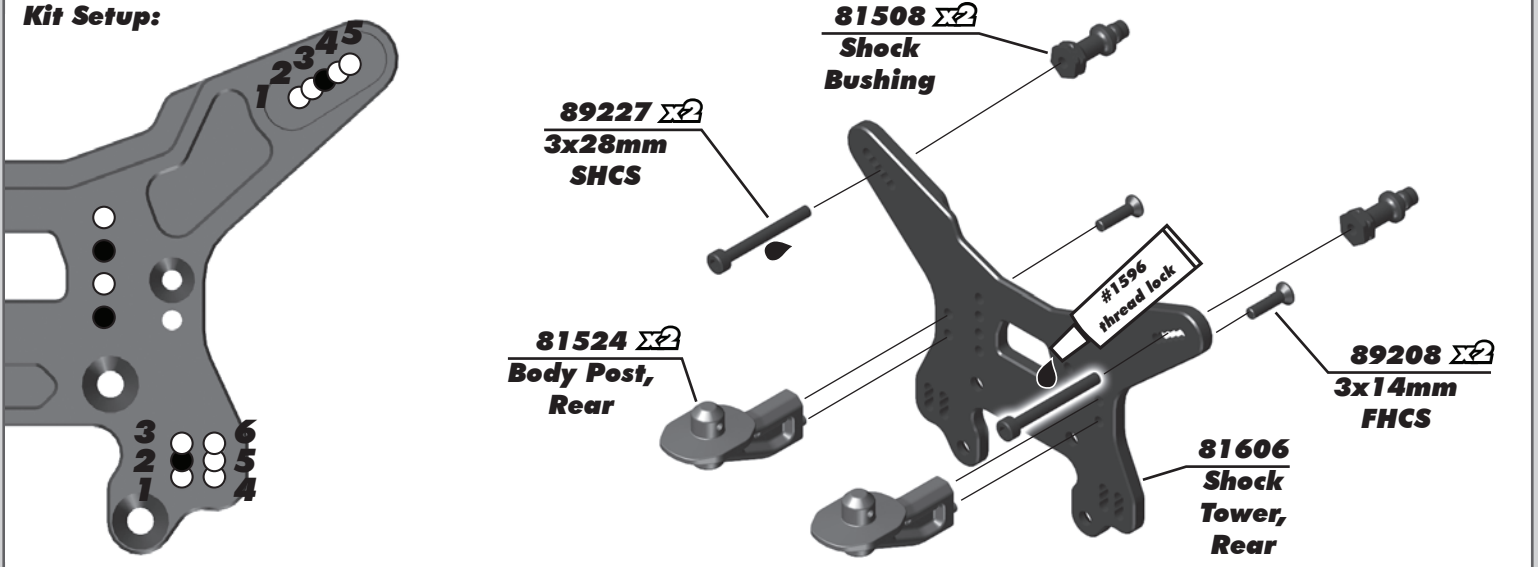

:: Rear End Build - Bag 7.1, 7.2, 7.3 - Step 9



CHOOSE ONE
 Fin adds straight-line stabilization.
 Button adds agility in corners.

89208 X2
3x14mm FHCS

81553 X2
Wing Buttons

81553
Wing, Black

81552 X2
Wing Angle Shim, -2

81552
Wing Mount

25215 X2
M3 Locknut



Refer to previous step (8) for wing height position

81552 X2
Wing Mount Adapter

25215 X4
M3 Locknut

89454 X4
3x12mm SHCS

:: Rear End Build - Bag 7.1, 7.2, 7.3 - Step 10

89214 X4
4x12mm FHCS

:: Rear Hubs Build - Bag 8.1 - Step 1

Build two!

81328
CVA Coupler

#6588
black grease

91565 X2
8x16x5mm Bearing, Flanged

81545
Rear Hub Insert, Offset (Low Axle)

81613
CVA Bone (131mm)

81547
CVA Axle, Steel

81545
Rear Hub

81328
CVA Coupler Pin

81548
CVA Axle Sleeve

2

1

3

4

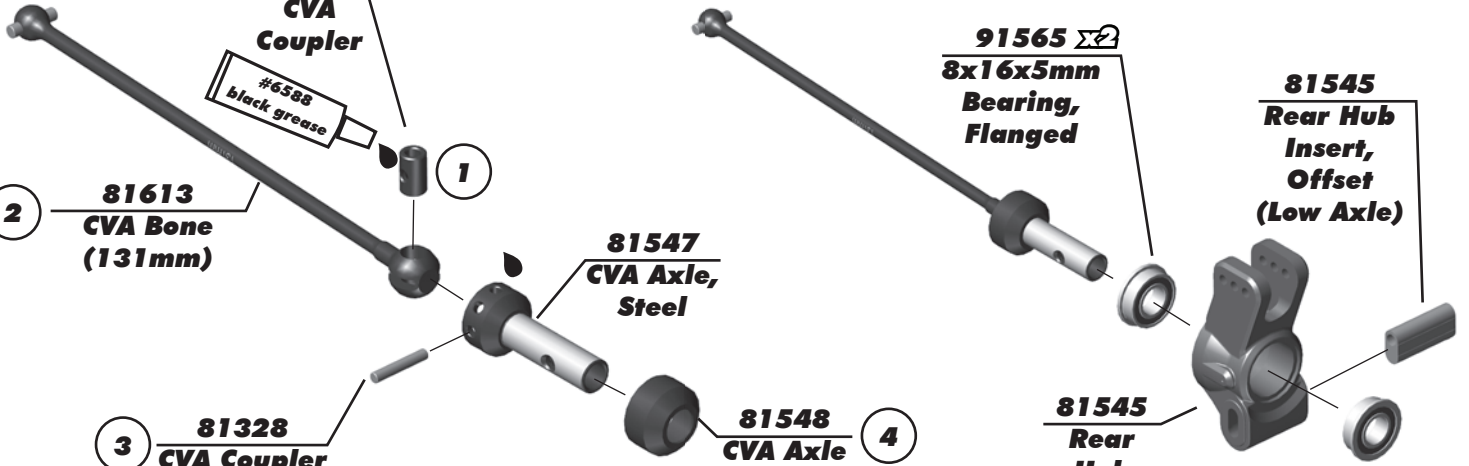

:: Rear Hubs Build - Bag 8.1 - Step 2

81257 $\Sigma 2$
3x6mm
Set Screw

89096
Wheel
Hex Pin

81319
Wheel Hex
Retaining
Ring

81319
Wheel Hex

89221
5x4mm
Set Screw

#1596
thread lock

Clamp

Slide the Hex Drive Clamp **PAST** the groove on the 17mm Hex Drive when installing onto the CVA Drive Shaft.

Once the Wheel Hex Pin and 5x4mm Set Screw has been installed, slide the Hex Drive Clamp **IN** the groove on the 17mm Hex Drive.

:: Rear Hubs Build - Bag 8.1 - Step 3
Install left and right side!

Kit Setup:

81545
Rear Hub
Shim, 2.5mm

81545
Rear Hub
Shim, 1.5mm

81076
Hub Hinge
Pin

25211
3x10mm
BHCS

#1596
thread lock

25612
M3 Locknut
w/Flange

81545
Rear Hub
Shim, 1.0mm

89204
3x24mm
BHCS

:: Rear Hubs Build - Bag 8.1 - Step 4

Tuning Tip:
Remove screw A for "soft/short" flex configuration.

A B

89216 $\Sigma 2$
M4
Locknut

81264 $\Sigma 2$
4x20mm
FHCS

89214 $\Sigma 4$
4x12mm
FHCS

Kit Setup:
Mount the rear shock in the outside hole on the rear arm.

AB

25612
M3 Locknut
W/ Flange

81509
Shock
Pin

81257
3x6mm
Set Screw

:: RC8T4 Nitro Kit and RC8T4e Electric Kit

If you are building an RC8T4e Electric kit, continue on to Center Bulkhead Build below this step.

If you are building an RC8T4 Nitro kit, go to page 23 to build the Center Bulkhead.

:: Center Bulkhead Build - 9.1 - Step 1 (RC8T4e)



Note: Do not use brake rotor guides on center bulkheads



Note: The upper center bulkheads have "F" for front and "R" for rear.

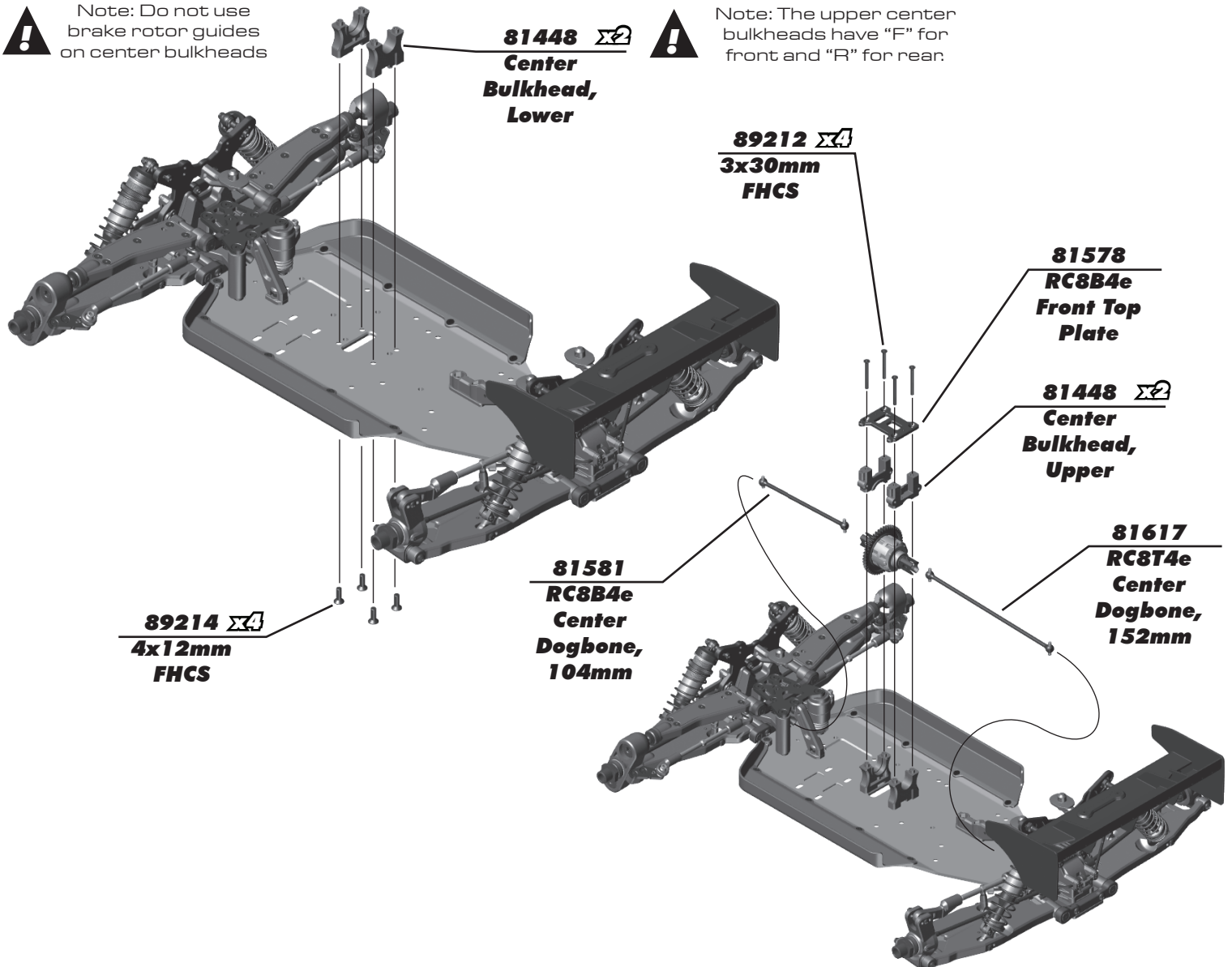

:: Center Bulkhead Build - 9.1 - Step 2 (RC8T4e)

81582 $\Sigma 2$
RC8B4e
Motor Mount, Lower

31520 $\Sigma 2$
2.5x6mm
BHCS

81572 $\Sigma 2$
RC8B4e **Wire**
Routing Clips

81114 $\Sigma 4$
Engine Mount
Washer

81262 $\Sigma 4$
4x10mm
FHCS

#1596
thread lock

89454 $\Sigma 4$
3x12mm
SHCS

81582 $\Sigma 2$
RC8B4e
Motor Mount, Upper

#1596
thread lock

! Optional! 30mm fan (not included)

! Fan, motor, and pinion not included. If installing a fan, attach before installing motor mounts. Hardware not included. Maximum screw depth 4mm.

:: Center Bulkhead Build - 9.1 - Step 3 (RC8T4e)

(not included)

41094 $\Sigma 4$
3x14mm
LP SHCS

31518
2.5x4mm
FHCS

(not included)

81572 $\Sigma 2$
RC8B4e
Receiver Box, Lower

81572 $\Sigma 1$
RC8B4e
Receiver Box Wire Clip

! Install servo mount wire clip 1st, then the receiver box to the chassis

81572
RC8B4e
Receiver Box, Upper

81572
RC8B4e
Servo Mount Wire Clip

4675 $\Sigma 3$
2.5x6mm
FHCS

4675 $\Sigma 1$
2.5x6mm
FHCS

89214 $\Sigma 2$ **2**
4x12mm
FHCS

:: Center Bulkhead Build - 10.1 - Step 4 (RC8T4e)

Spline Count



Printed here
23T
25T

81556
Servo Horn
(Steering)

81556
Servo Horn
Insert

25215
M3
Locknut

91048
HD Ball
Stud, 8mm

#1596
thread lock

25211
3x10mm
BHCS

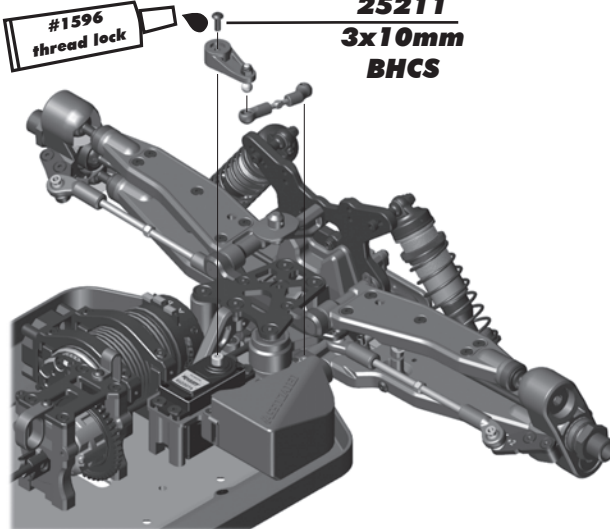

:: Center Bulkhead Build - 11.1 - Step 5 (RC8T4e)

6727
Servo
Tape

(not included)

81572
ESC Tray

81584 $\times 2$
Hook and
Loop Strap

25201 $\times 4$
3x8mm
FHCS

81574 $\times 2$
Battery
Tray Spacer

81262 $\times 2$
4x10mm
FHCS

81574
Battery
Tray

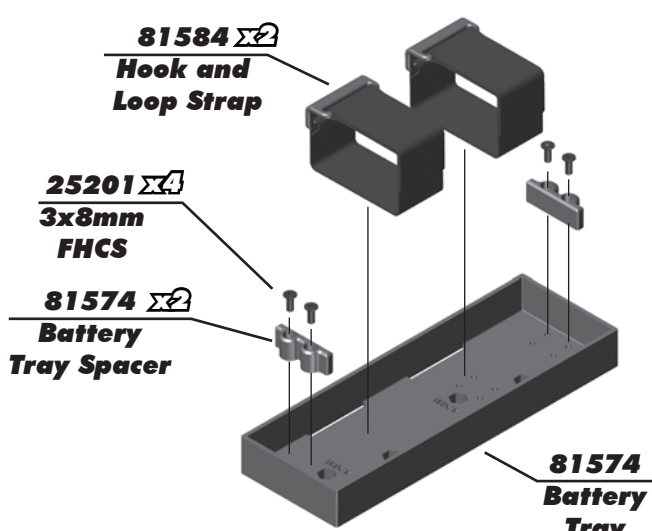
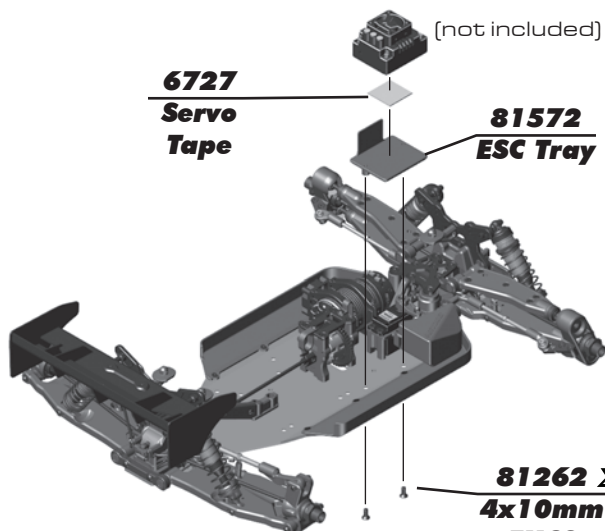

:: Center Bulkhead Build - 11.1 - Step 6 (RC8T4e)

89216 $\times 4$
M4
Locknut

(not included)

81262 $\times 4$
4x10mm
FHCS

RC8T4e
Build End

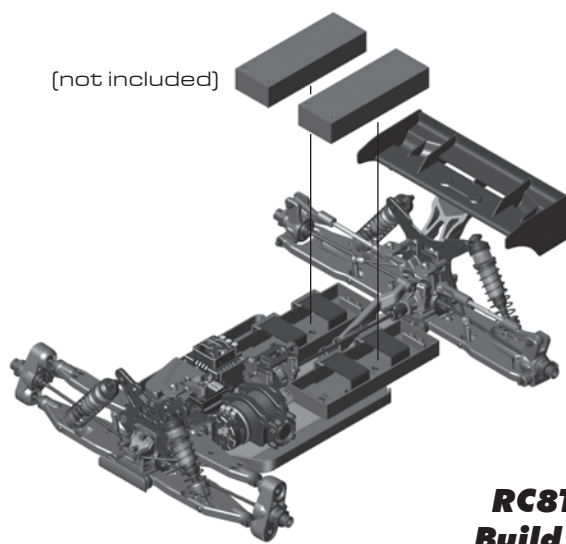
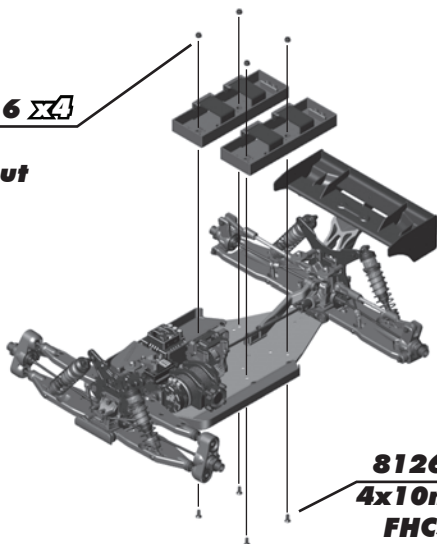

:: Center Bulkhead - Bag 9.1 - Step 1 (RC8T4 Nitro)

RC8T4 Nitro Build Continued

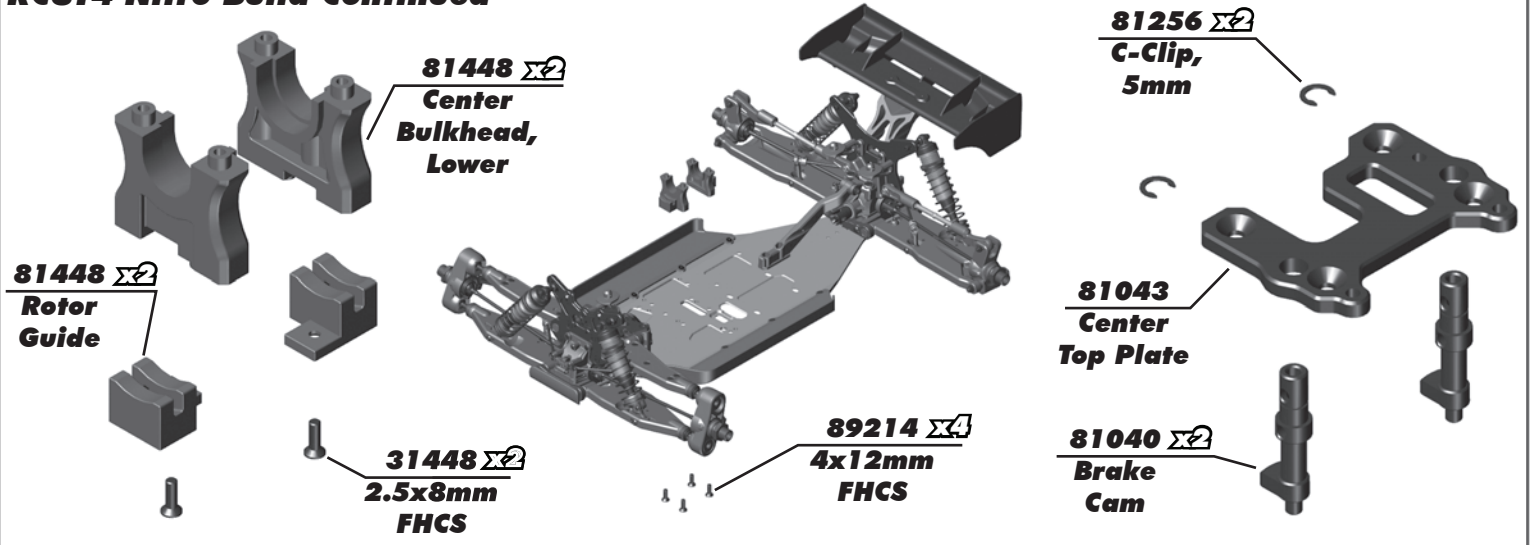

:: Center Bulkhead - Bag 9.1 - Step 2 (RC8T4 Nitro)

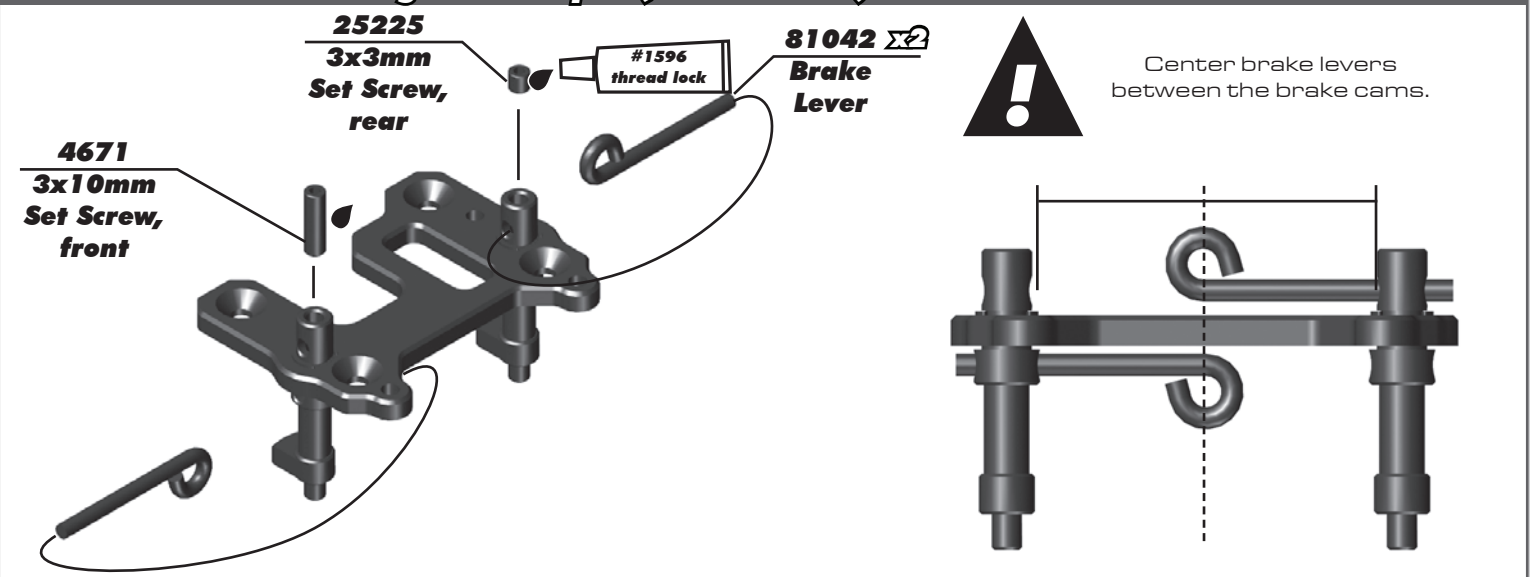

:: Center Bulkhead - Bag 9.1 - Step 3 (RC8T4 Nitro)

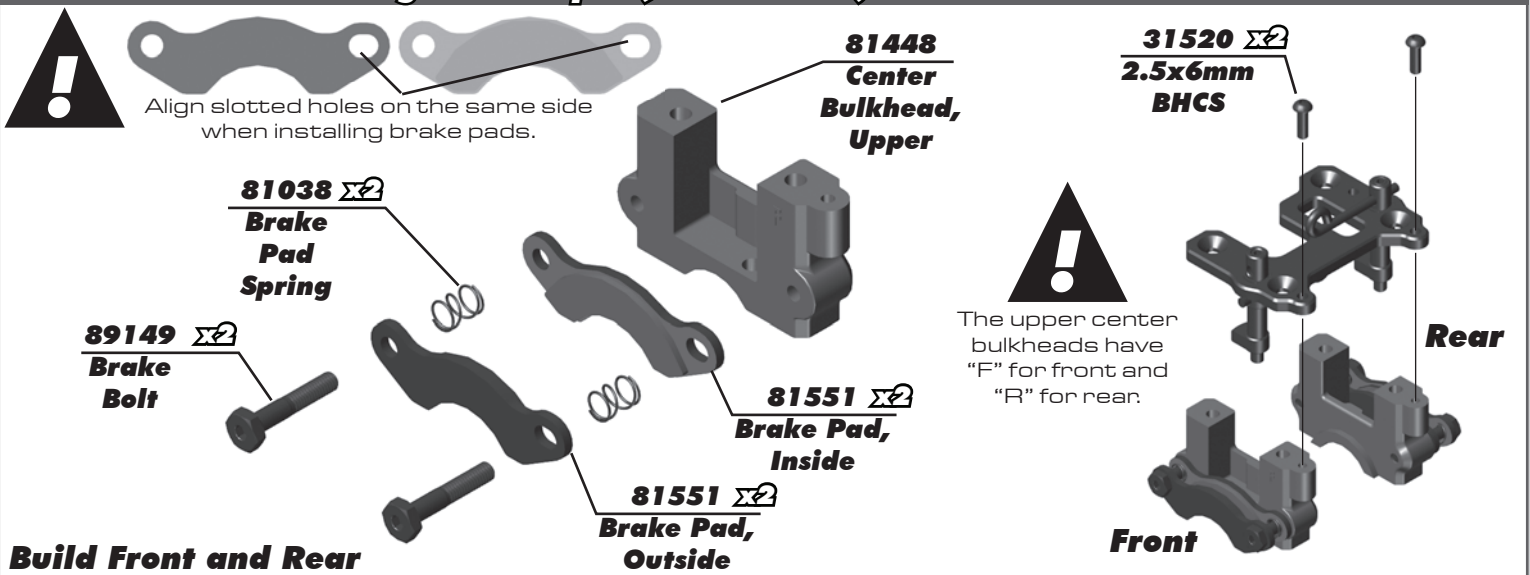

:: Center Bulkhead - Bag 9.1 - Step 4 (RC8T4 Nitro)

18.40mm (0.72")

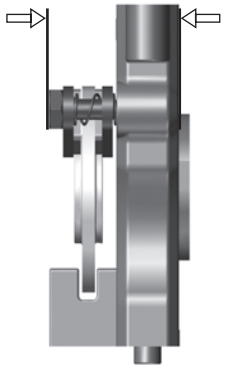

89212 $\Sigma 4$
3x30mm
FHCS

81550
Brake
Rotor

81564
Center
Dog Bone,
86.5mm

81615
Center
Dog Bone,
174mm

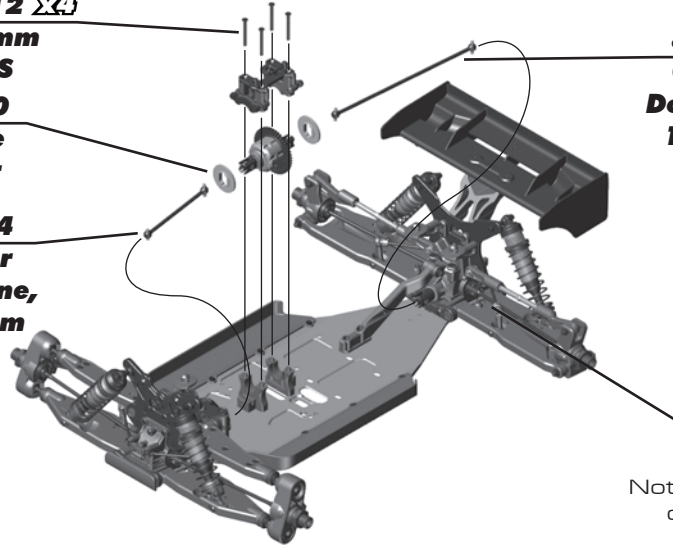

Note direction of center diff.

:: Linkages Build - Bag 10.1 - Step 1 (RC8T4 Nitro)

7184
2x16mm
SHCS

81555
Servo
Horn Pivot

81555
Pivot
Bushing,
Brake

81556
Servo Horn,
Throttle

81555
Lower Pivot,
Throttle

81251
2x10mm
SHCS

81251 $\Sigma 3$
Washer

81555
Pivot
Bushing,
Throttle

81556
Servo Horn
Insert

81555
Lower Pivot,
Brake

81555
Throttle
Link

81555
Throttle
Spring

81555
Set Collar

81555
Throttle
Ball Cup

81555 $\Sigma 2$
Brake
Link

81555 $\Sigma 3$
Brake Bias
Collar

25225 $\Sigma 4$
3x3mm
Set Screw

#1596
thread lock

Spline Count

Printed here
23T
25T

:: Linkages Build - Bag 10.1 - Step 2 (RC8T4 Nitro)

Recommended Starting Positions:
Front Brake Gap
7.75mm

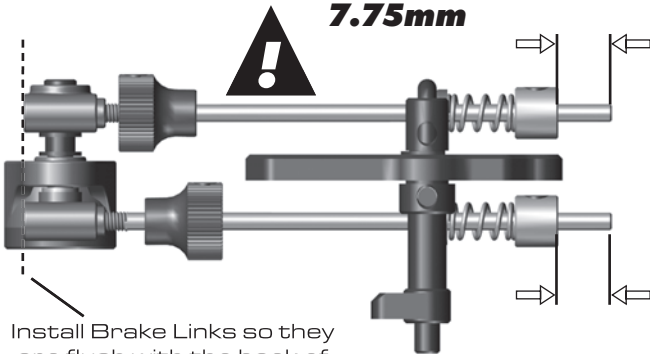

Install Brake Links so they are flush with the back of the servo horn pivots.

Rear Brake Gap
4.5mm

25225 $\Sigma 2$
3x3mm
Set Screw

81555 $\Sigma 2$
Set Collar

81555 $\Sigma 2$
Brake
Spring

81555 $\Sigma 2$
Brake Linkage
Spring Ball

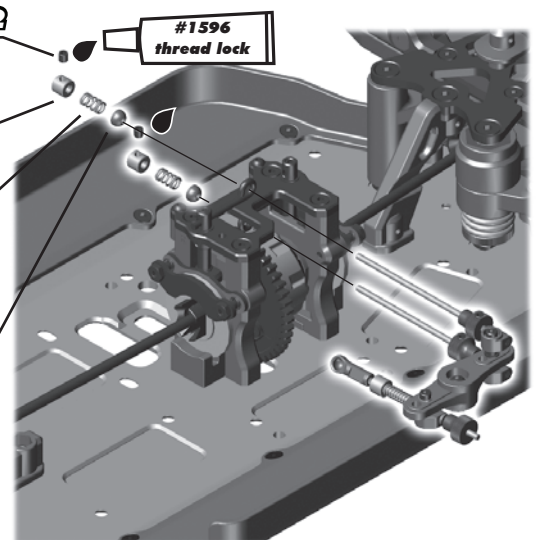

:: Linkages Build - Bag 10.1 - Step 3 (RC8T4 Nitro)

Spline Count



Printed here
23T
25T

81556
Servo Horn
(Steering)



81556
Servo Horn
Insert



25215
M3
Locknut



91048
HD Ball
Stud, 8mm

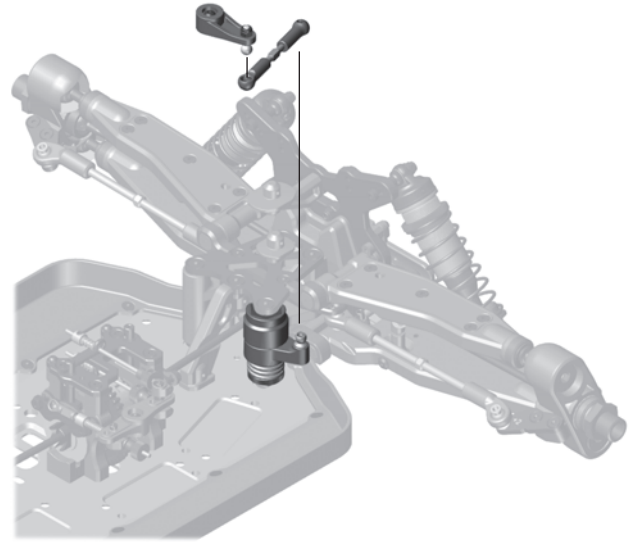

:: Radio Tray Build - Bag 11.1 - Step 1 (RC8T4 Nitro)

Radio Tray Configuration:

The radio tray on RC8B4 can be configured in four different ways. Each configuration changes the amount and location of flex in the chassis. Experiment with different configurations when running on different surfaces.

When removing either graphite radio tray brace or transponder mount, utilize included plastic shims to maintain proper servo height.

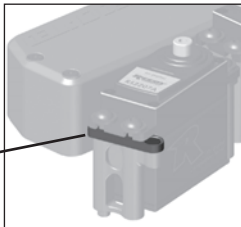

81433
Radio Tray
Spacer

Option 1

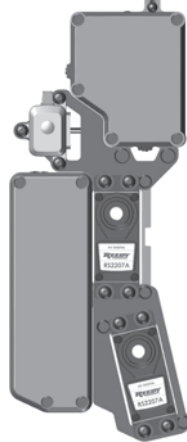

Least Flex
(Kit Setup)

Option 2

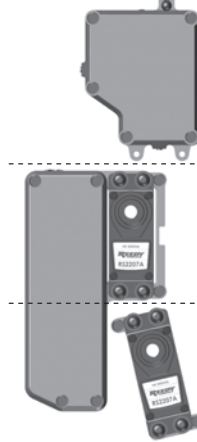

Most Flex

Option 3

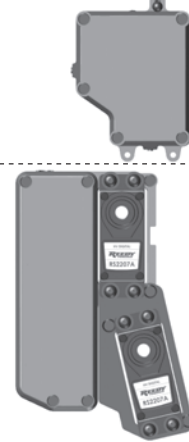

More Rearward
Flex

Option 4

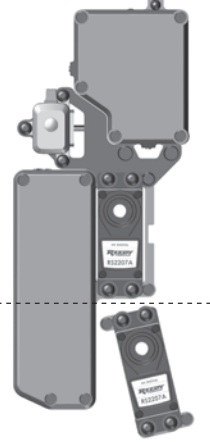

More Frontward
Flex

:: Radio Tray Build - Bag 11.1 - Step 2 (RC8T4 Nitro)

31448 x4
2.5x8mm
FHCS

81561
Radio
Tray Brace

81433 x2
Radio
Tray Post

41094 x4
3x14mm
LP SHCS

Servo not included!

41094 x4
3x14mm
LP SHCS

Servo not included!

25201 x2
3x8mm
FHCS

81450
Transponder
Mount

81432
Battery Box,
Bottom

81432
Receiver
Box, Bottom

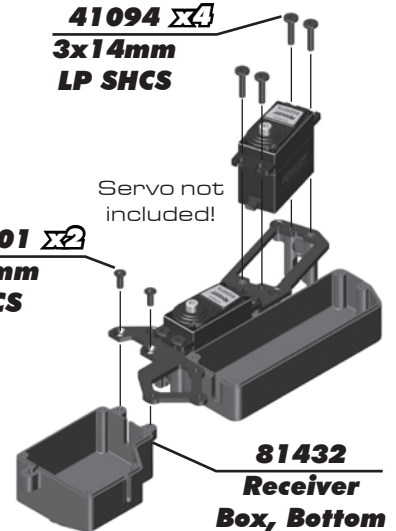
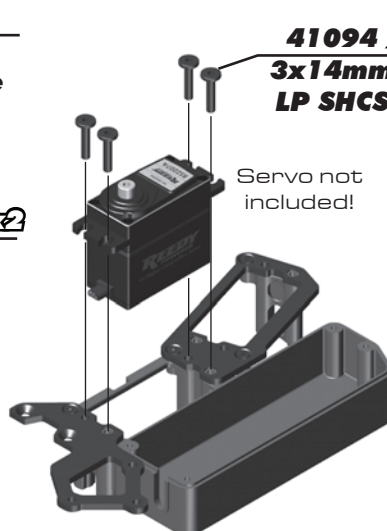
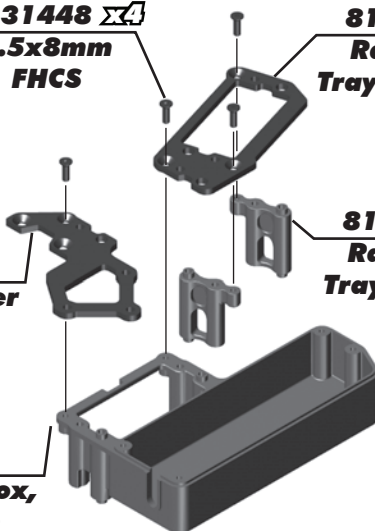

:: Radio Tray Build - Bag 11.1 - Step 3 (RC8T4 Nitro)

42007 $\Sigma 2$
Receiver
Box
Grommet

42007 $\Sigma 2$
Grommet
Plug

Receiver Battery
not included!

Receiver
not included!

6727
Servo
Tape

31448 $\Sigma 9$
2.5x8mm
FHCS

81432
Receiver
Box, Top

81432
Battery
Box, Top

:: Radio Tray Build - Bag 11.1 - Step 4 (RC8T4 Nitro)

25225
3x3mm
Set Screw

25211 $\Sigma 3$
3x10mm
BHCS

On/Off switch
not included!



Racer's Tip:
Center servos
before horn
installation!

6338
Antenna
Tube and
Cap

Transponder
not included!

25215 $\Sigma 3$
M3 Locknut

!
The switch and
transponder
positions can be
reversed if desired

#1596
thread lock

25211 $\Sigma 2$
3x10mm
FHCS

89214 $\Sigma 6$
4x12mm
FHCS

:: Clutch / Filter Build - Bag 12.1, 12.2 - Step 1 (RC8T4 Nitro)

Engine
not included!

81372
Flywheel
Nut

81371
Flywheel
Collet



Racer's Tip:
No thread lock
on the flywheel
nut.

81370
Flywheel,
4-Shoe

!
See next step for
clutch shoe/spring
installation order!

81373 $\Sigma 4$
Clutch
Shoe Pins



:: Clutch / Filter Build - Bag 12.1, 12.2 - Step 2 (RC8T4 Nitro)

Clutch Shoe / Spring Installation Order:



Short end of clutch shoe spring installed into flywheel.
Long end of clutch shoe spring installed into clutch shoe.

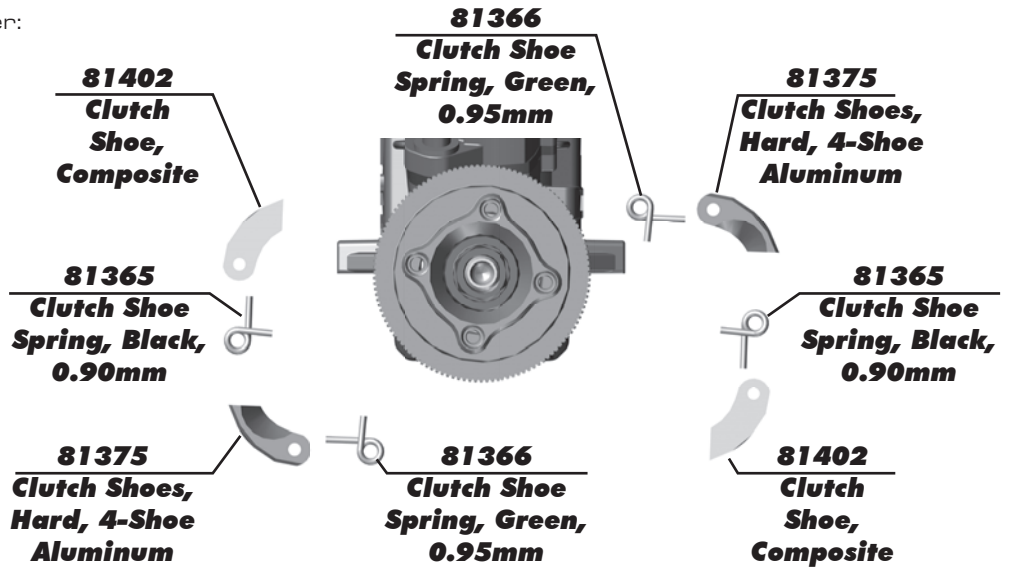

:: Clutch / Filter Build - Bag 12.1, 12.2 - Step 3 (RC8T4 Nitro)

Clutch shimming instructions:

- Build assembly with shims as shown
- If clutch bell does not spin freely:
Move shim from behind clutch bell to in front of clutch bell
- OR-
- Remove one shim from front of clutch bell
- Recommended axial play in clutch bell = 0.2mm - 0.5mm

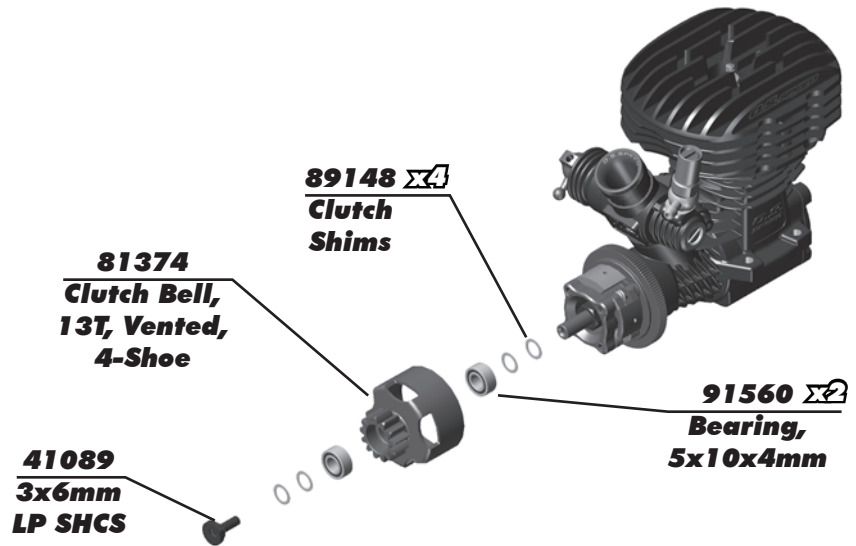

:: Clutch / Filter Build - Bag 12.1, 12.2 - Step 4 (RC8T4 Nitro)



When oiling the filter elements, place both inside a plastic bag and squeeze to help evenly coat the filter.

:: Clutch / Filter Build - Bag 12.1, 12.2 - Step 5 (RC8T4 Nitro)

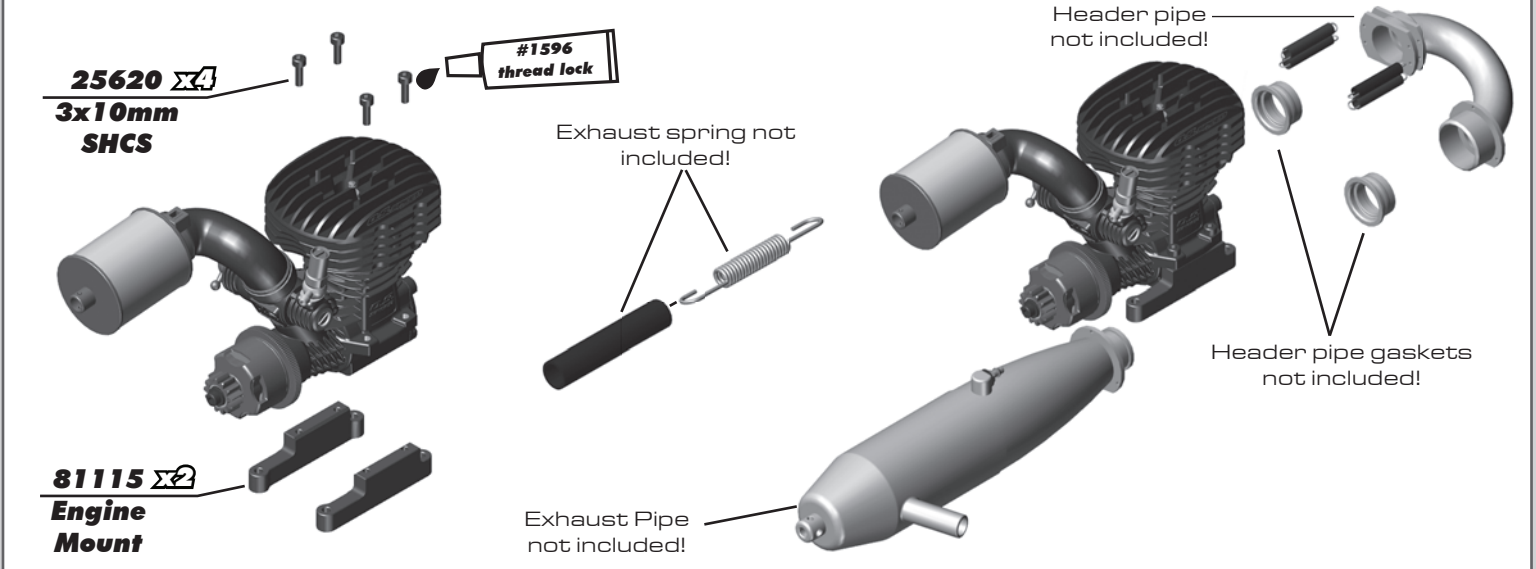

:: Clutch / Filter Build - Bag 12.1, 12.2 - Step 6 (RC8T4 Nitro)

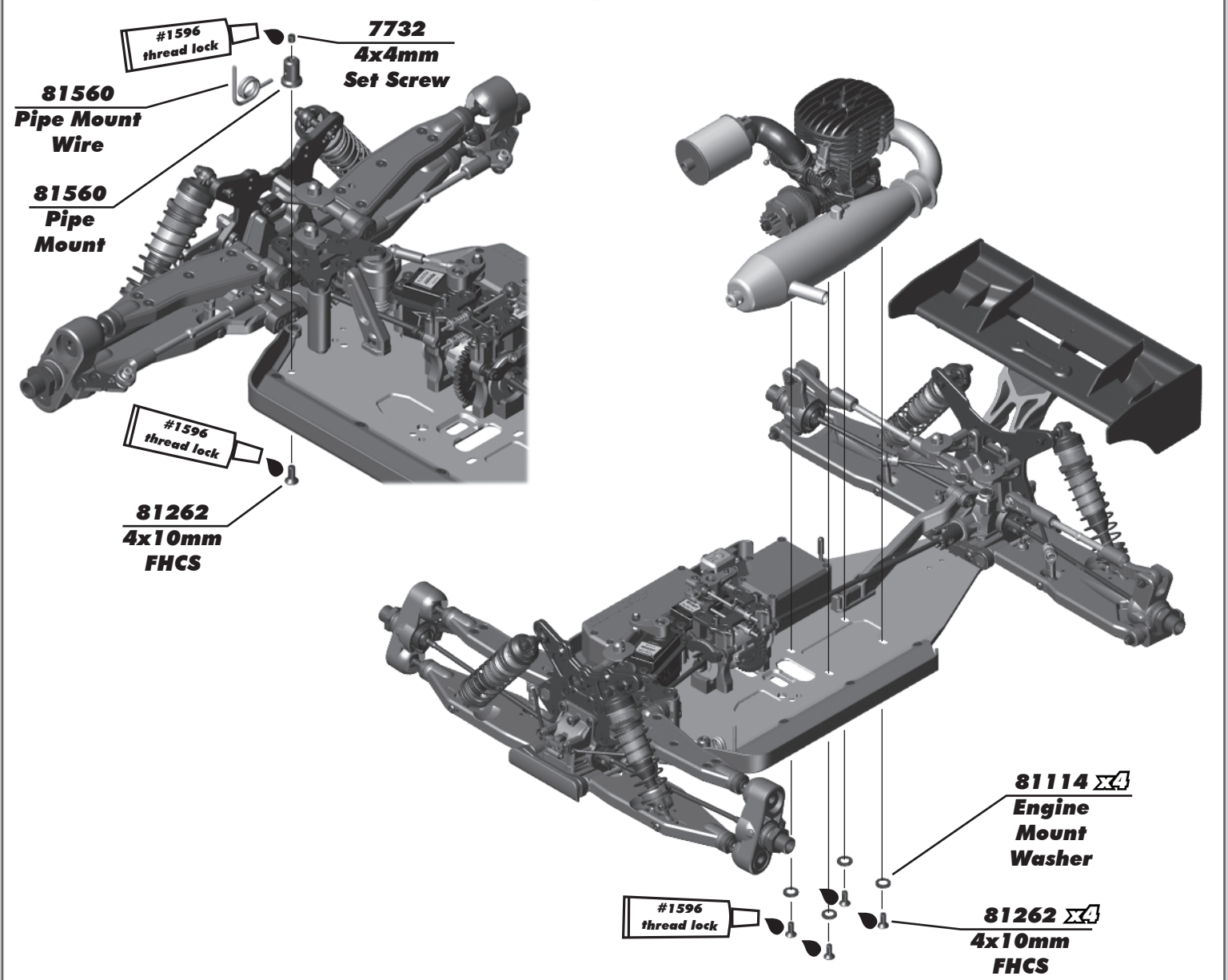

:: Clutch / Filter Build - Bag 12.1, 12.2 - Step 7 (RC8T4 Nitro)



When installing your engine, make sure the rear drive shaft does not interfere with the engine block. You may need to remove material from the engine block for fitment.

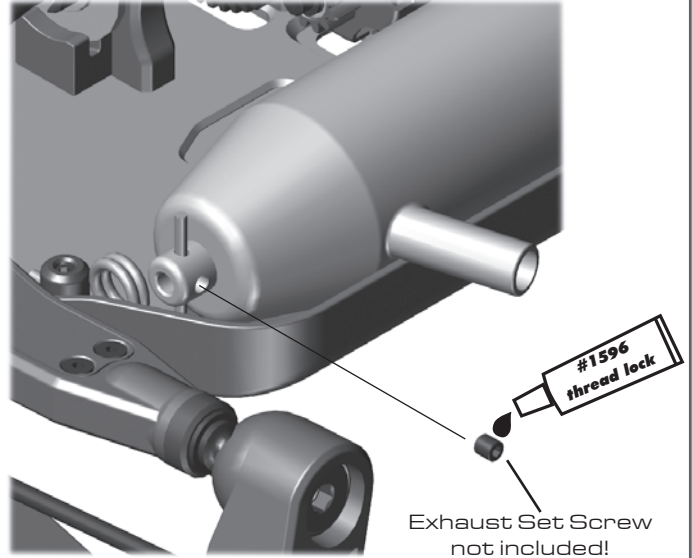
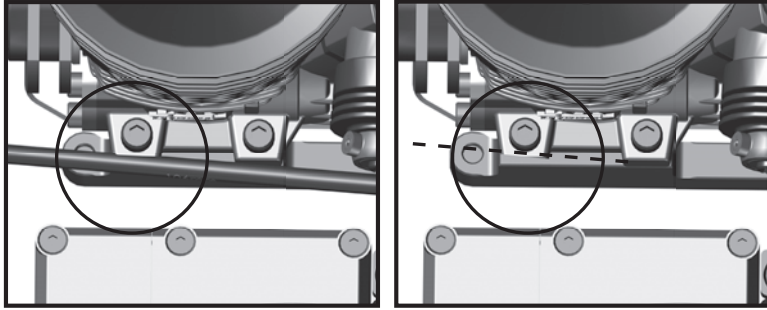

:: Fuel Tank Build - Bag 13.1, 13.2 - Step 1 (RC8T4 Nitro)

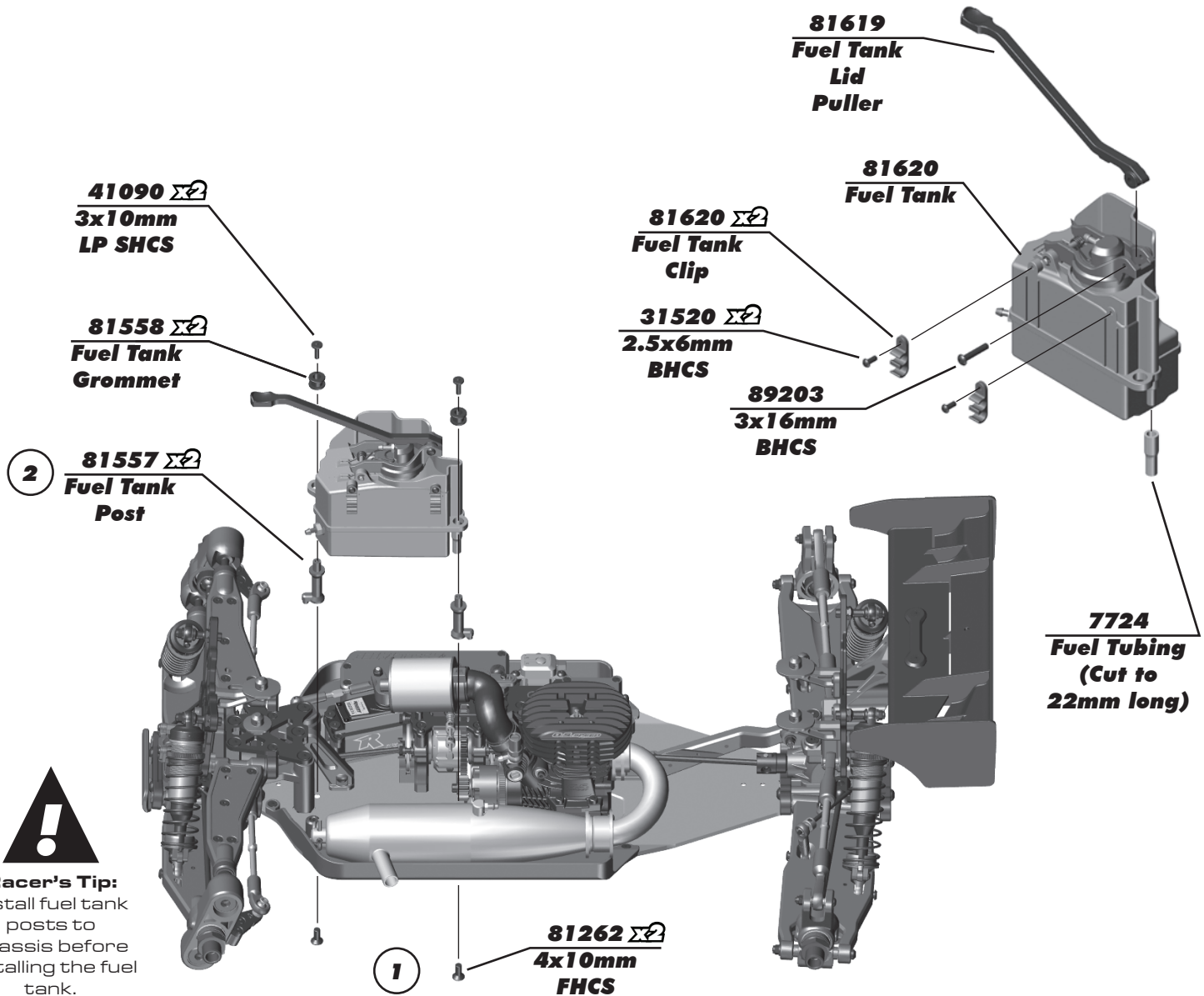

Racer's Tip:
Install fuel tank posts to chassis before installing the fuel tank.

:: Fuel Tank Build - Bag 13.1, 13.2 - Step 2 (RC8T4 Nitro)

Pressure line from
fuel tank lid to
exhaust pipe

Fuel line from fuel
tank to carburetor

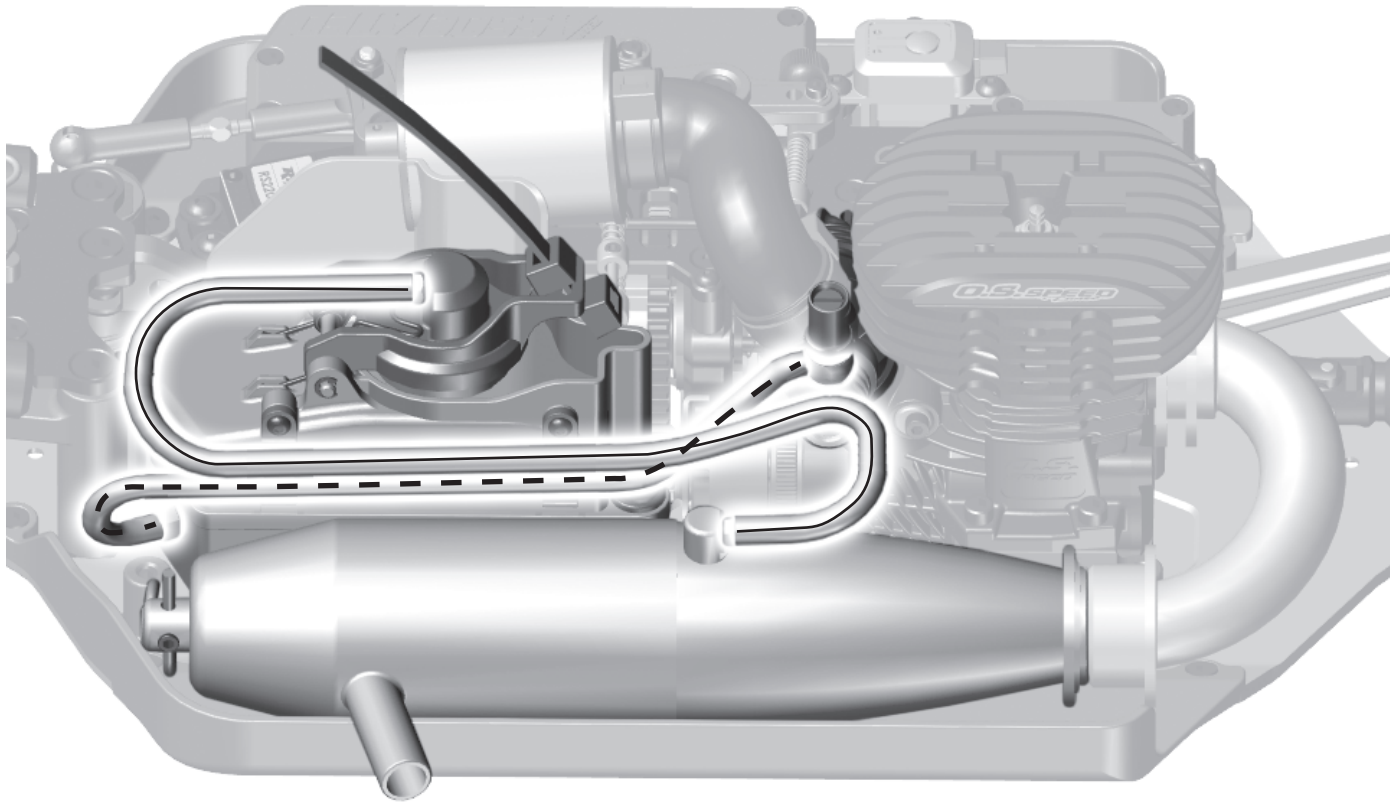

:: Wheels / Tires / Body - Misc. - Step 1

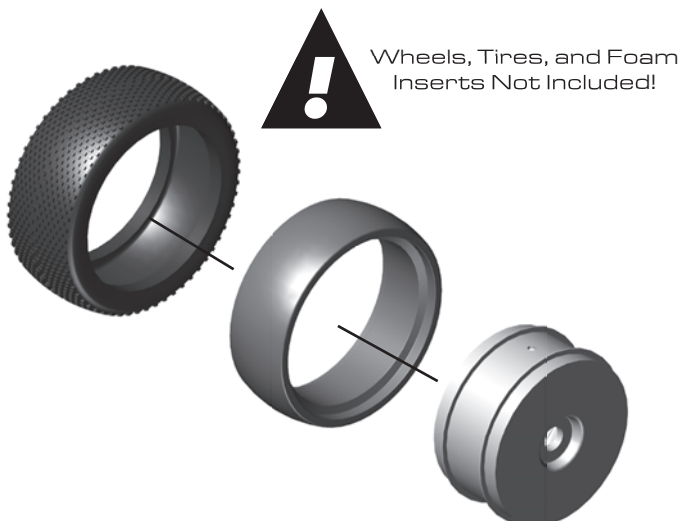

Tires:

When gluing tires to wheels, use a fast-curing tire glue (CA) [AE # 1597]. This is available at your local hobby shop. Make sure to clean the mounting surface of the tire and wheel with alcohol for best adhesion.

:: Wheels / Tires / Body - Misc. - Step 2



Install wheel nuts with the serrated edge towards the wheel.

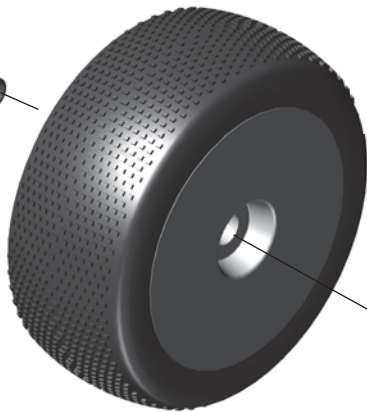
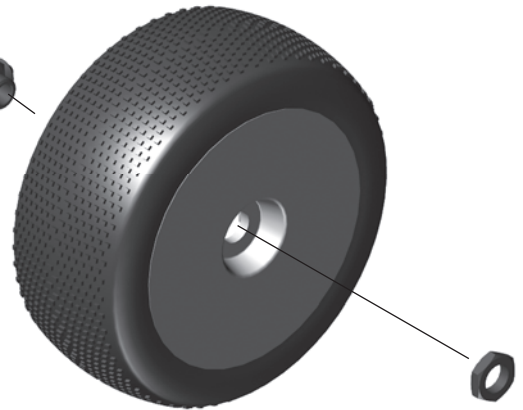
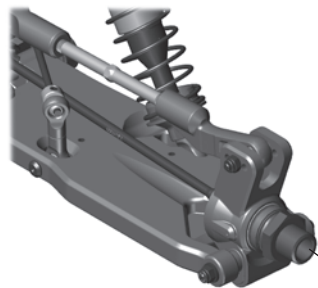
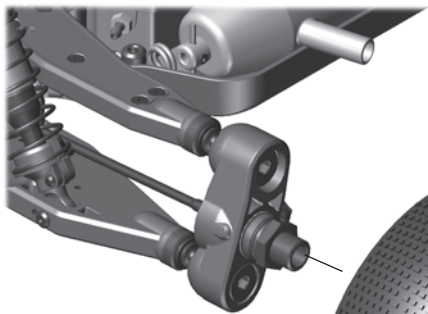

81082 
Wheel Nuts,
17mm
(Blue)

:: Wheels / Tires / Body - Misc. - Step 3

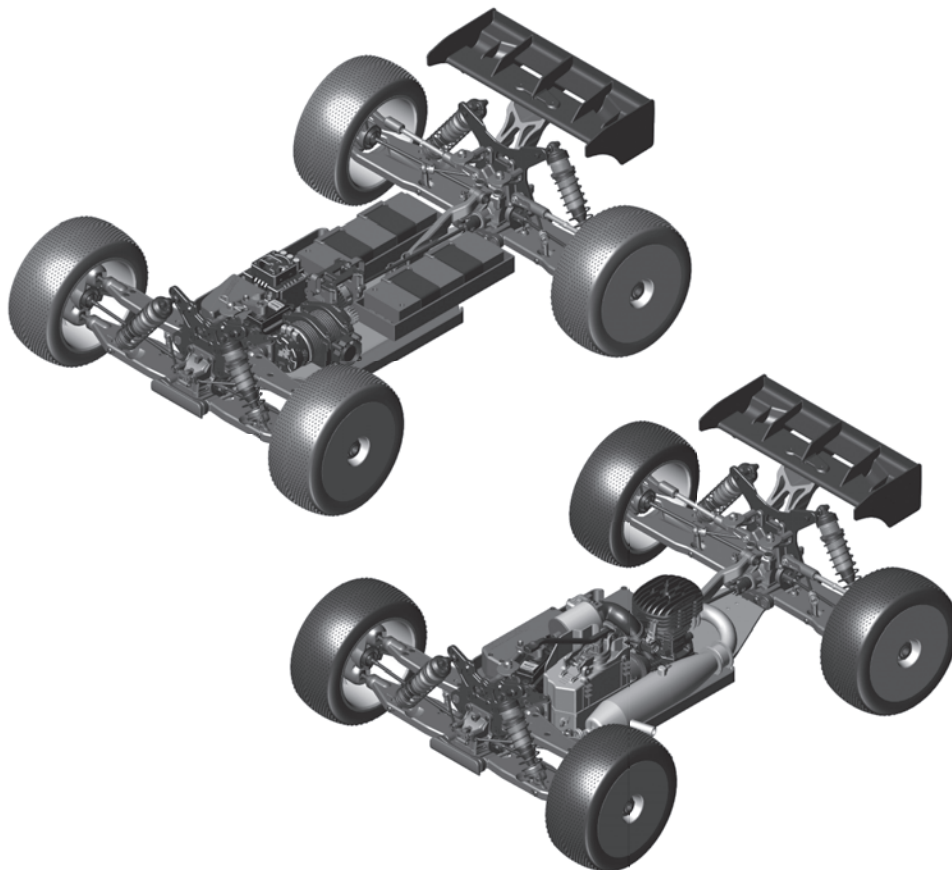

Painting Tips:

Your kit does not come with a clear polycarbonate body. You will need to prep the body before you can paint it. Wash the inside thoroughly with warm water and liquid detergent. Dry the body using a clean, soft, lint-free cloth. Install the window masks on the inside of the body. (RC cars get painted on the inside). Using high quality masking tape, apply tape to the inside of the body to create a design. Spray (either rattle can or airbrush RC specific paint) the paint to the inside of the body (preferably dark colors first, lighter colors last).

NOTE: use ONLY paint that is recommended for use with (polycarbonate) plastics. If you do not, you can destroy the polycarbonate body!

After painting, cut the body along the trim lines. Make sure to drill or use a body reamer to make the holes for the body mounts and antenna!

:: Droop Settings

Set droop by measuring overall length of shock (from standoff to shock pin) while the chassis is elevated above your working surface. The shocks should be fully extended.

Kit setup for front droop is 105mm shock length, and 127mm shock length for the rear.

If the shock length is too long, adjust by turning the droop screws clockwise.

If the shock length is too short, adjust by turning the droop screws counter-clockwise.

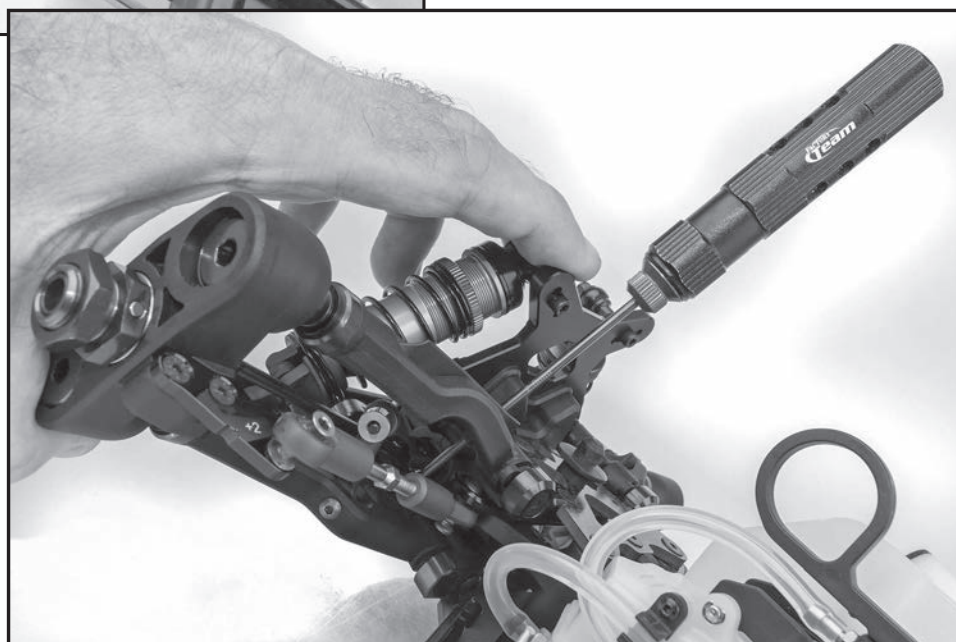
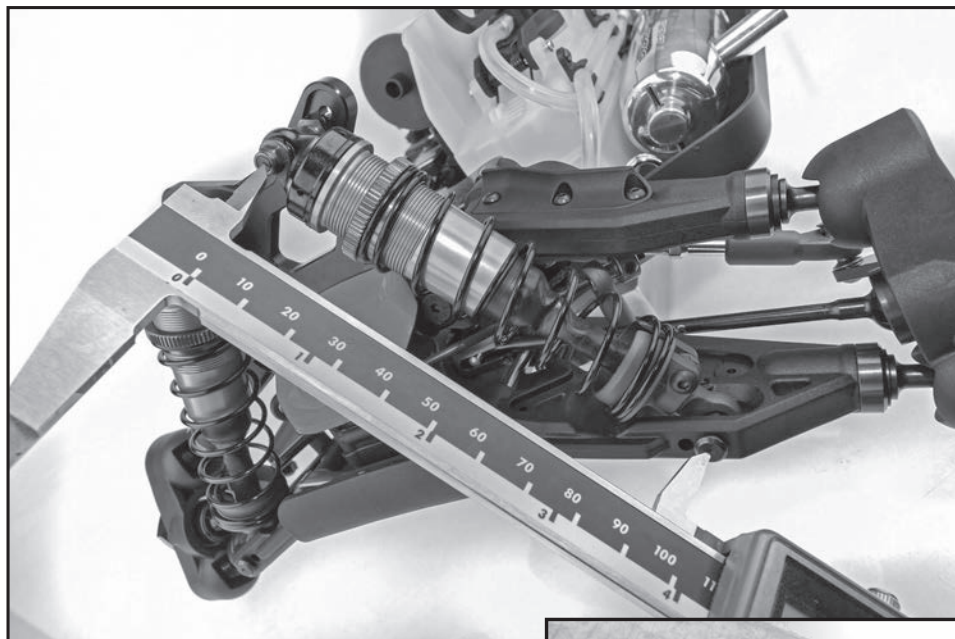

Front Droop: Increasing front droop (loosen droop screws) will increase off-throttle steering. It also allows the front end to lift more, giving more rear grip and less front grip on-power. Remember to never loosen the screws beyond the FULL DROOP setting. Decreasing front droop (tighten droop screws) yields more on-power steering and quicker response at the expense of some stability in bumpy sections. It will also give less off-throttle steering.

Rear Droop: Increasing rear droop (loosen droop screws) will increase traction in bumpy sections, but will reduce high-speed stability. Remember to never loosen the screws beyond the FULL DROOP setting. Decreasing rear droop (tighten droop screws) will increase stability in high speed sections, but will reduce stability in bumpy sections.

Setup Sheets:

To find different setups for your kit, visit our website, <https://www.associatedelectrics.com/teamassociated/> and click on the "Setup Sheets" link, and then the link to your model. Our team of professional drivers help develop these setups at races worldwide. Additionally, most drivers have a "base" setup that they use as a starting point for most races. Try running some of our base setups or look for track conditions and tires that are similar to your local track and replicate that setup. Remember, each adjustment has a purpose, so copy everything from the setup sheet and then make adjustments based on the recommendations in here.

CARS & TRUCKS



Vehicle Spare Parts

GO TO:

- AssociatedElectrics.com** →
- Team Associated tab** →
- Cars & Trucks** →
- Scroll to your vehicle** →
- Parts & Accessories link**

SETUP SHEETS & MANUALS



Setups and Manuals

GO TO:

- AssociatedElectrics.com** →
- Team Associated tab** →
- Manuals & Setups** →
- Scroll to your vehicle**

A-TEAM APPS



Tuning Guides & Tips

GO TO:

- AssociatedElectrics.com** →
- Support** →
- A-Team Apps**



Associated Electrics, Inc.

21062 Bake Parkway Lake Forest, CA 92630 USA

call: (949) 544-7500 - fax: (949) 544-7501

Check out the following web sites for all of our kits, current products, new releases, setup help, tips, and racing info!

www.AssociatedElectrics.com

FOLLOW US ON SOCIAL MEDIA



**TeamAssociated
ReedyPower
ElementRC**



**@TeamAssociatedRC
@ReedyPower
@Element_RC**



**@Team_Associated
@ReedyPower**