

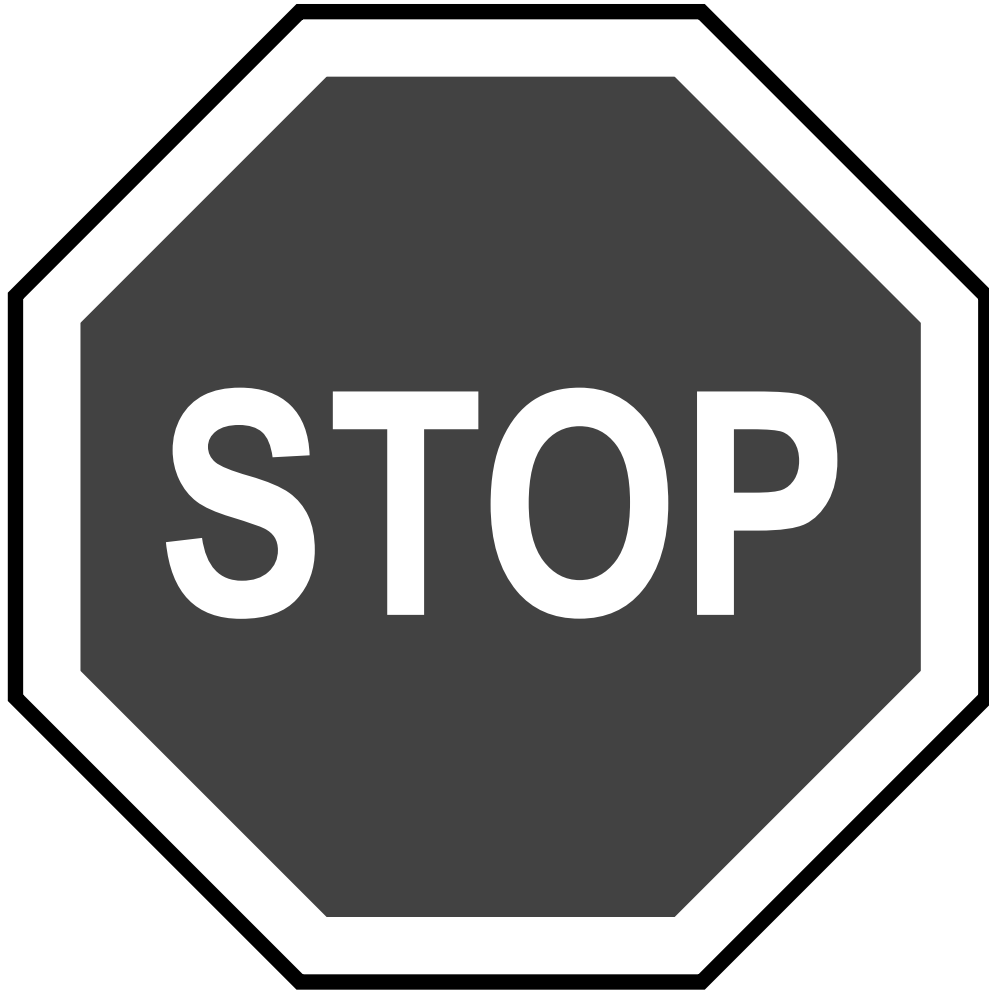

**SUPER PNP**  
Instruction Manual



**BEFORE CONTINUING WITH THIS INSTRUCTION MANUAL OR ASSEMBLY OF YOUR AIRCRAFT, PLEASE VISIT OUR WIKI PAGE SUPPORT SITE FOR THE LATEST PRODUCT UPDATES, FEATURE CHANGES, MANUAL ADDENDUMS, AND FIRMWARE CHANGES FOR BOTH YOUR AIRCRAFT AND THE INSTALLED AURA 8 ADVANCED FLIGHT CONTROL SYSTEM.**

**[wiki.flexinnovations.com/wiki/MAMBA60](http://wiki.flexinnovations.com/wiki/MAMBA60)  
[wiki.flexinnovations.com/wiki/Aura](http://wiki.flexinnovations.com/wiki/Aura)**

# TABLE OF CONTENTS

Introduction .....	2	Rudder and Elevator Linkage Installation .....	13,14
Box Contents .....	2	Horizontal Stabilizer Installation.....	15
Specifications.....	3	Main Wing Installation.....	16,17,18
Replacement Parts Listing.....	3	Propeller, Spinner, and Baffle Installation.....	19
Optional Completion Items.....	3	Battery Installation and C.G. Verification .....	20
Completion Items .....	3	Control Direction Test .....	21
Battery Charging Guidelines.....	3	Flight Control Sensing Direction Test .....	22
Special Language Definitions .....	4	Pre-Flight Checks.....	23
Important Information Regarding Warranty.....	4	Flying your Mamba 60.....	24
Safety Warnings and Precautions.....	4	Advanced Mamba 60 Setup.....	25
Low Voltage.....	4	Aircraft Troubleshooting Guide.....	26
Tailwheel and Rudder installation.....	5	Airframe Repairs .....	27
Main Landing Gear Installation .....	6,7	Replacing Servos .....	27
Aura 8 ACFS .....	8	Servicing the Power System .....	27
Transmitter Setup.....	9	Limited Warranty.....	28
Connecting Battery/Arming ESC.....	10	AMA Safety Code .....	29
Receiver Installation/Servo Connections.....	11,12,		

## INTRODUCTION

With many decades of aerodynamic design and having won F3A and 3D championships with his biplane designs, Quique Somenzini strives for the utmost in flight perfection. Starting with the Model 12 from Jim Kimball Enterprises, Quique has made various aerodynamic and geometric design changes over the years to further refine the performance of the Model 12, and perfect it as a 3D and aerobatic model biplane. These years of design experience and astute attention to every aerodynamic detail allow an aerobatic biplane experience not available anywhere else.

The Mamba 60E takes that core design a step further, combining a stiff yet light weight structure with massive amounts of wing area for the lightest wing loading possible. Quique also minimized control coupling to match this modern airframe design with explosive power to unleash the incredible 3D performance.

The foam EPO structure is highly optimized using various materials in key locations like carbon fiber and plywood to create an aircraft that is stiff and strong, yet light in weight. The Mamba 60E's motor and aluminum landing gear is mounted to its plywood sub-structure, keeping everything rigid and lightweight.

Each of the four wing panels are easily removed by one screw and the interplane struts use retention pins to secure the wings, making transportation to the field a breeze.

The Aura 8 Flight control system brings out the best in every airframe. It makes the aircraft fly as if it is larger and more stable and minimizes the effect of the wind. Pilots also rave about its direct and true feeling and its ability to NOT feel "in the way".

All of this combines to make the Mamba 60E+ an unbeatable performer in a massive yet convenient size!

The Mamba 60E is fully licensed by Jim Kimball Enterprises.

## BOX CONTENTS



## SPECIFICATIONS

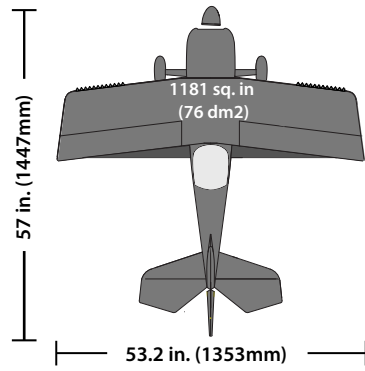

NIGHT VERSION	DAY VERSION
8.30lb (3770g) RTF with 6S 5200mAh battery installed	8.05lb (3650g) RTF with 6S 5200mAh battery installed
7.98lb (3620g) RTF with 6S 4200mAh battery installed	7.71lb (3500g) RTF with 6S 4200mAh battery installed



## REPLACEMENT PARTS

FPM3970A	Mamba 60E+ Super PNP Red Scheme
FPM3970B	Mamba 60E+ Super PNP Yellow Scheme
FPM3980A	Mamba 60E+ Super PNP Night Red Scheme
FPM3980B	Mamba 60E+ Super PNP Night Yellow Scheme
FPM397001	Mamba 60E+: Fuselage
FPM397002L	Mamba 60E+: Top/Bottom Wing Left panels
FPM397002R	Mamba 60E+: Top/Bottom Wing Right panels
FPM397003	Mamba 60E+: Tail set
FPM397004	Mamba 60E+: Hatch set
FPM397005	Mamba 60E+: Aluminum Landing Gear Set
FPM397006	Mamba 60E+: Wing/Stab Tube Joiner Cabanne Tube Set
FPM397007	Mamba 60E+: Hardware Package
FPM397008	Mamba 60E+: Red/Black Decal Set
FPM397009	Mamba 60E+: Yellow/Blue Decal set
FPM397010	Mamba 60E+: Right/Left Inter-Plane Strut Set
FPM397011	Mamba 60E+: Top Wing Center Section
FPM397012	Mamba 60E+: Tail Gear Set
FPM397013	Mamba 60E+: Interplane Strut Pin Set (4)
FPM397014	Mamba 60E+: Key Chain Camera Mount
FPM398001	Mamba 60E+: Fuselage Night w/LEDs
FPM398002L	Mamba 60E+: Top/Bottom Wing Left panels w/LEDs
FPM398002R	Mamba 60E+: Top/Bottom Wing Right panels w/LEDs
FPM398003	Mamba 60E+: Top Wing Center Section w/LEDs
FPM398004	Mamba 60E+: LEDs Strip L/R Stab w/ Spot Light Set
FPZM10653D	Potenza 6S 3D 550 Kv BL Motor
FPZDS34HV	Potenza DS34HV Servo
FPZM10603D1	Potenza 60 Bolt On Prop Adapter 60 3D
FPZM10603D3	Potenza 60 Bolt Motor Shaft 60 3D
FPZM10603D2	Potenza 60 Bolt Aluminum X-Mount 60 3D
HWBQ8012EBHV	SKYWALKER 80A w/EXTERNAL 7.4V-8A BEC
FPMP1606E	SR Propeller 16 x 6E
FPM337017	QQ Cap 232 EX: Spinner
FPM397017	Mamba 60E+: Wheel Pant and Wheel Set
FPM397012	Mamba 60E+: Tail Gear Set
FPM337016	QQ Cap 232 EX: (2) Main and Tail Wheel Collar Set
FPM337014	QQ Cap 232 EX: Ball Link Set (5)
FPZA1016	Potenza Advance R/C LED Controller (6s)
FPZAURA08ZZM60	Aura 8 for Mamba 60E+
FPZA1017	1.5-inch Plastic Servo Arm (2)

## OPTIONAL ACCESSORIES

FPZA1010	Potenza Digital Battery Analyzer
FPZB13003S25	Potenza 3S 1300mAh 20C Li-Po (for LEDs)
FPZB13003S40	Potenza 3S 1300mAh 40C Li-Po (for LEDs)
FPZB42006S40	Potenza 6S 4200mAh 40C Li-Po
FPZB52006S40	Potenza 6S 5200mAh 40C Li-Po
FPZB42006S75	Potenza 6S 4200mAh 75C Li-Po
FPZB52006S75	Potenza 6S 5200mAh 75C Li-Po
FTVHWBQ2006	Hobbywing ESC Programming Card
SPMAR8010T	Spektrum AR8010T Receiver
FUTR2001SB	R2001SB S.BUS S-FHSS Receiver
FUTR7003SB	R7003SB S.BUS FASSTest
FUTR7008SB	R7008SB S.BUS FASSTest
FUTT6K	Futaba T6K Transmitter w/R3006SB Rx
IDSTD2	iDST D2 Smart AC Dual Battery Charger 100W x 2 6s
IDST8	ISDT T8 Charger
FPZA1027	ISDT Charge Lead Adapter

## COMPLETION ITEMS

INSTALLED!		Potenza 6S 3D 550 Kv BL Outrunner Motor (FPZM10653D)
INSTALLED!		HobbyWing SkyWalker 80A ESC w/External 7.4V-8A BEC (HWBQ8012EBHV)
INSTALLED!		Potenza DS34HV Servo (FPZDS34HV)
INSTALLED!		Aura 8 Advanced Flight Control System (FPZAURA08ZZM60)
INCLUDED!		SR 16 x 6 Electric Propeller (FPMP1606E)
NEEDED TO COMPLETE		3500-5200mAh 6S 22.2v 40C LiPo (FPZB42006S40)
NEEDED TO COMPLETE		6-Channel Computer Transmitter*
NEEDED TO COMPLETE		DSM2/DSMX (2) remote receivers SRXL/S.Bus Futaba/Graupner SumD/ JR XBus/Jeti UDI 5+ Channel RX (any brand)

## BATTERY CHARGING GUIDELINES

### WARNING

FOLLOW ALL INSTRUCTIONS PROVIDED BY YOUR BATTERY AND CHARGER MANUFACTURER. FAILURE TO COMPLY CAN RESULT IN FIRE.

The assembly of the Mamba 60E+ can be accomplished in less than one hour. Prior to assembling the airplane, it is advisable to charge your battery so that you are ready to begin setup upon completion of the assembly of your model.

We recommend the use of an advanced LiPo balancing charger for your batteries to get the maximum performance and lifespan from them.

Our airplanes are designed around our Potenza LiPo batteries and we recommend the Potenza 6S 4200-5200mAh 30C+ LiPo a in the Mamba 60 based on our extensive testing and development. This battery features an EC5 connector, no soldering is required for use in your Mamba.

All are available online at [www.flexinnovations.com](http://www.flexinnovations.com) and your local Flex Innovations retailer.

## SPECIAL LANGUAGE DEFINITIONS

The following terms are used throughout the product literature to indicate various levels of potential harm when operating this product:

- NOTICE:** Procedures, which if not properly followed, create a possibility of physical property damage AND a little or no possibility of injury.
- CAUTION:** Procedures, which if not properly followed, create the probability of physical property damage AND a possibility of serious injury.
- WARNING:** Procedures, which if not properly followed, create the probability of property damage, collateral damage, and serious injury OR create a high probability of serious injury.



### WARNING

## AGES 14+

This product is not intended for use by children under 14 years without direct adult supervision.

### ATTENTION

Read the ENTIRE instruction manual to become familiar with the features of the product before operating. Failure to assemble or operate the product correctly can result in damage to the product, personal property, and cause serious or fatal injury.

All instructions, warranties and other collateral documents are subject to change at the sole discretion of Flex Innovations LLC, Inc. For up-to-date product literature, please visit our website at [www.flexinnovations.com](http://www.flexinnovations.com) and click on the Mamba 60E+ and Aura 8 product pages.

---

## IMPORTANT INFORMATION REGARDING WARRANTY

Please read our Warranty and Liability Limitations section before building this product. If you as the Purchaser or user are not prepared to accept the liability associated with the use of this Product, you are advised to return this Product immediately in new and unused condition to the place of purchase.

---

## SAFETY WARNINGS AND PRECAUTIONS

Protect yourself and others by following these basic safety guidelines.

1. This manual contains instructions for safety, operation and maintenance. It is essential to read and follow all the instructions and warnings in the manual, prior to assembly, setup or use, in order to operate correctly and avoid damage or serious injury.
2. This model is not a toy, rather it is a sophisticated hobby product and must be operated with caution and common sense. This product requires some basic mechanical ability. Failure to operate this product in a safe and responsible manner could result in injury or damage to the product or other property.
3. This model must be assembled according to these instructions. Do not alter or modify the model outside of these instructions provided by Flex Innovations, Inc, as doing so may render it unsafe and/or unflyable. It is your responsibility to ensure the airworthiness of the model.
4. Inspect and check operation of the model and all its components before every flight.
5. If you are not an experienced pilot or have not flown a high-performance model before, it is recommended that you seek assistance from an experienced pilot in your R/C club for your first flights. If you're not a member of a club, the Academy of Model Aeronautics (AMA) has information about clubs in your area whose membership includes experienced pilots.
6. Keep the propeller area clear from such items such as loose clothing, jewelry, long hair, or tools as they can become entangled. Keep your hands and body parts away from the propeller as injury can occur.
7. Never fly in visible moisture or submerge the airplane or any of its electronic components in water. Permanent damage to electronic components may occur, or corrosion of components may lead to intermittent failures.

---

## LOW VOLTAGE CUTOFF

LiPo batteries have a nominal (rated) voltage of 3.7v per cell, and fully charged, reach 4.2v per cell. Batteries are designed to be discharged below the nominal voltage. However, if they are discharged below 3.0v per cell, damage will occur and the pack will lose capacity. For best long term battery life, set a timer and land after a time that leaves approximately 15% of the battery's capacity remaining.

Low voltage cutoff is a feature that is built into the Hobby Wing SkyWalker 80A ESC that is designed to protect the connected battery from being discharged too far and causing permanent damage to the cells. Circuitry within the ESC will automatically detect when the input voltage from the battery pack reaches below 3.15v per cell (average) and will remove power to the motor, but still deliver power to the servos so that a safe landing may be made. If the motor begins to lose power rapidly during flight, the LVC has sensed that the total voltage of the pack has dropped below 3.15v per cell average, and the airplane should be landed immediately.

# RUDDER AND TAIL WHEEL INSTALLATION

## Required Tools and Fasteners

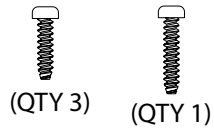

- Medium CA (or 5-15 min epoxy)
- #1 Phillips Screwdriver
- (3) M3x8 Phillips head self-tapping screw
- (1) M3x10 Phillips head self-tapping screw

1. Locate the Tail wheel, Tail wheel retaining plate, and the three M3x8 self-tapping Phillips head screws. Insert the tail wheel wire into the base of the rudder orienting the tail wheel so the wire is angled towards the rear of the airframe as it moves away from the fuselage. Insert the tail wheel retaining plate into the recessed area at the base of the rudder. Use a #1 Phillips screwdriver for the (3) M3x8 self-tapping screws to secure the retaining plate to the rudder.
2. The rudder comes pre-hinged to a small section of the vertical fin. Test fit the rudder and fin section onto the fuselage then remove it from the fuselage once proper fit is confirmed.
3. Lay the fuselage on its side, and using medium CA (foam-safe is not required) or epoxy, apply an adequate amount to the fuselage. Press the rudder and vertical fin section onto the fuselage, being sure to wipe away any excess glue.
4. Allow time for the CA or Epoxy to dry, and once dry, check for proper rudder movement. Be sure the rudder moves freely with little to no binding
5. Secure the lower plastic hinge in place by threading the M3x10 Phillips head self-tapping screw through the bottom of the plastic hinge in the fuselage. \* Do not fully tighten, as it will cause the rudder to bind. A small amount of play is needed here.

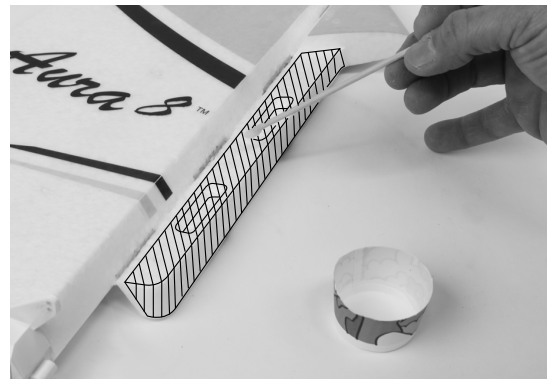
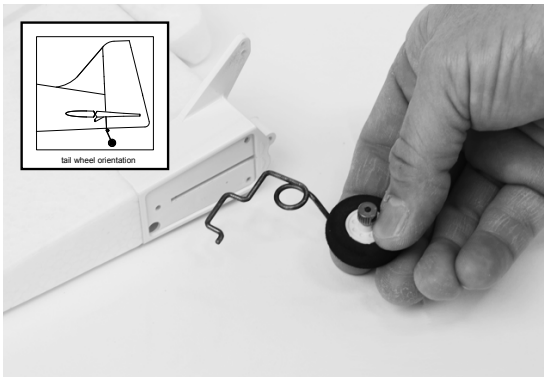

# MAIN LANDING GEAR INSTALLATION

## Required Tools, Parts, and Fasteners



#1 Phillips Screwdriver  
7mm open end wrench (2)

(2) M4 Lock Nuts  
(2) M4 washers  
(2) M3 X 10 Machine Screw  
(4) M3 X 14 Machine Screw  
Blue Thread Lock

1. Locate the landing gear, axle assemblies, wheel pants, and M4 lock nuts and washers.
2. Use a Phillips screwdriver to remove the M3x12 self-tapping screws from the wheel pants, and separate the wheel pant halves from one another.

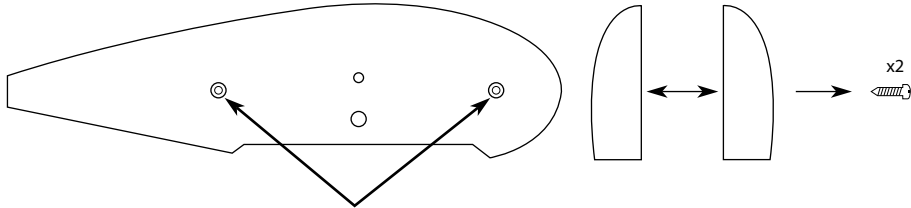

3. Remove the M4 lock nut and washer from the axle assembly (if required). Slide the axle through the landing gear, and place an M4 washer over the exposed threads of the axle. Secure the axle in place using an M4 lock nut and two 7mm wrenches. Tighten fully.

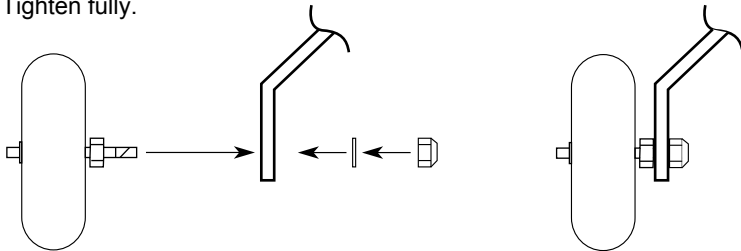

4. Install the inside-half of the wheel pant to the landing gear using an M3x10 Phillips head machine screw and blue thread lock. If you wish to leave the wheel pants off the aircraft, you can skip this step as well as step 5.

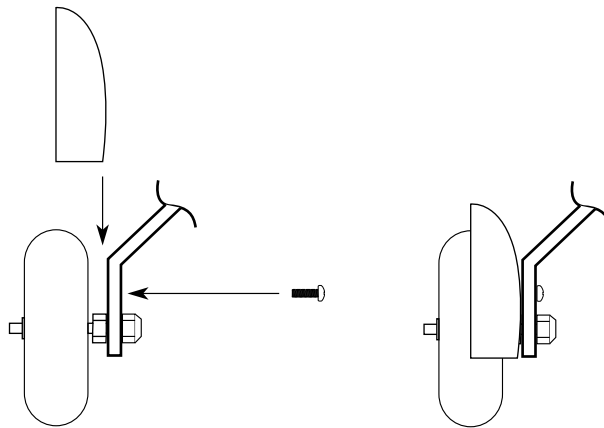

5. Re-install the outside half of the wheel pant to the inner half using the M3x12 self-tapping screws removed in step 2.

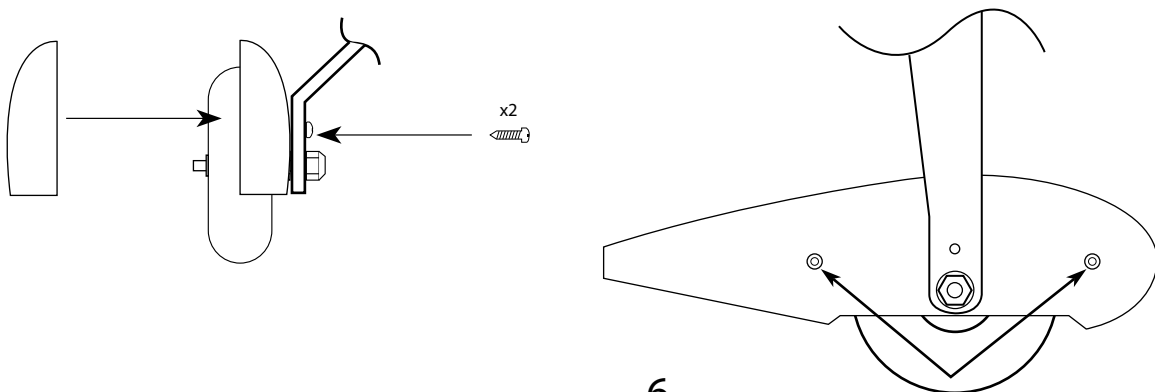

## MAIN LANDING GEAR INSTALLATION (CONTINUED)

6. With the fuselage inverted on your work space, place the landing gear on the landing gear mount. Be sure to orient the landing so that it sweeps forward towards the front of the airframe

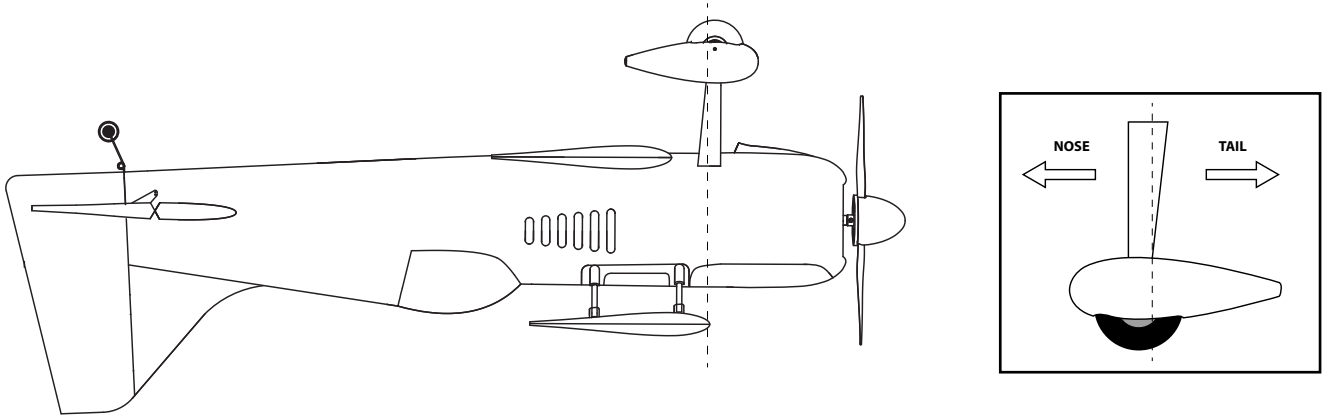

7. Apply a small amount of Blue thread lock to all 4 M3x14 Phillips head screws. Insert them through the landing gear into the gear plate and tighten them to the fuselage using a Phillips screwdriver.

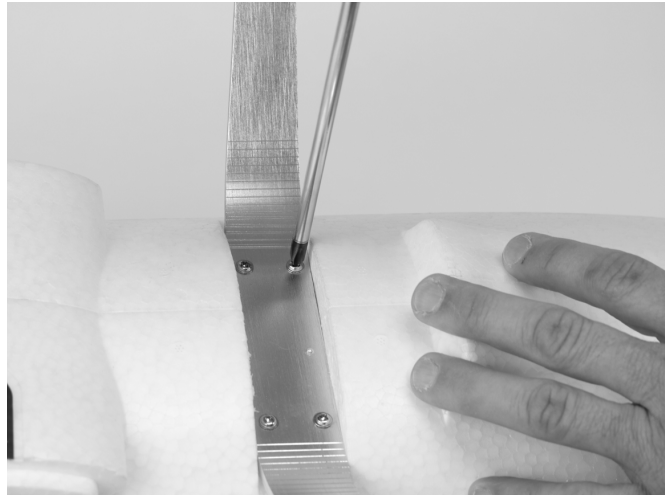



## AURA 8 AFCS

The Aura 8 Advanced Flight Control System (AFCS) installed in your Mamba 60 is a giant leap forward in aircraft flight control system technology. Compatible with virtually every receiver on the market today, the Aura features special configuration for DSM systems via remote receiver connection(s), and serial data connection for Futaba or Hitec S.Bus, Spektrum SRXL, Graupner HOTT (Sum D of 8), JR XBus (Mode B), and Jeti UDI12 (standard) systems, as well as being compatible with traditional receivers.

The Aura 8 advanced flight control system installed in your aircraft has been pre-tuned for ease of use, eliminating many hours of tedious setup. For the latest Aura features, programs, transmitter downloads, and instructions, please visit [wiki.flexinnovations.com/wiki/Aura](http://wiki.flexinnovations.com/wiki/Aura)

The Aura is programmable through any Windows based PC or tablet. All dual rate, expo, travel and assignable mode programs are adjusted inside the Aura through the PC application. An assignable master gain that is OFF by default can be enabled by the Aura application. If desired, assign CH 8/AUX 3 on a proportional dial or slider.

**By default, CH5/Gear is used to select the 3 flight modes by 3 position transmitter switch.** CH6/Aux 1 is used to manipulate the LEDs by 2 position transmitter switch.

- Works conveniently with all major radio systems
- Accepts signals from DSM Remote Receiver(s), Spektrum SRXL, Futaba S.Bus, Graupner Hott (Sum D of 8), JR XBus (Mode B), Jeti UDI12 (standard), Hitec S.Bus, PPM Stream
- Expertly tuned and ready to use
- USB port allows loading model configurations, user programming, and firmware updates (cable included)
- Flexible and extensive programming through Windows-based PC or tablet
- 3+ flight modes allow smooth or aggressive settings to be selected in flight
- 3-axis gyro utilized in Mamba 60 programming

**Visit [wiki.flexinnovations.com/wiki/Aura](http://wiki.flexinnovations.com/wiki/Aura) for the latest Aura-related product information and tips for your particular radio brand.**

---

### Description of Pre-Loaded Aura Flight Modes (FM)

#### Mode 1 (Gyro Off):

Gyro gain is set to 0 (off). All rates are set to low for general flight (same as Sport Mode). Exponential is tuned for comfortable flight.

#### Mode 2 (Sport):

Gyro gains are moderate and tuned for comfortable feel/best performance for general flight. All rates are set to low for general flight. Exponential is tuned for comfortable flight.

#### Mode 3 (3D):

Gyro gains are moderate and tuned for general flight. All rates are set to highest. Exponential is tuned for comfortable flight.

Each of the modes has been tuned by our team to offer a solid start. Because tastes in control feel are unique, if changes in rates and expo are needed, adjustments should be made through the Aura.

Changes in gain value can only be made through the Aura.

**To download the Aura Config Tool, please visit:  
<https://www.flexinnovations.com/articles.asp?ID=257>**

# ⚠ WARNING

DO NOT ATTEMPT RADIO SETUP WITH PROPELLER INSTALLED. INADVERTENT POWER UP COULD CAUSE DEATH OR SERIOUS INJURY.

## TRANSMITTER SETUP

The Aura 8 AFCS is designed to work seamlessly with all major transmitter and receiver brands. When programming your transmitter, start with a freshly reset new model memory in your transmitter. **Make ONLY the changes shown in the Transmitter Configuration Guide unless otherwise noted.**

The Aura 8 in your aircraft defaults to 3 flight modes that are switched via CH5/Gear in your transmitter. You may need to reassign CH5/Gear to a 3-position switch.

**Consult your transmitter manual if you have questions on how to change the switch or channel assignments.**

The Aura comes pre-programmed with dual rates and expos specifically designed for your aircraft. For large (greater than 5%) changes in expo or dual rates, it is highly recommended to reset all expos and rates to default in the transmitter, and tune through the Aura Config Tool.

**The Aura Config Tool is free to download, and can be used on any Windows-based PC or tablet. Download at:**

[www.flexinnovations.com/AuraConfigTool](http://www.flexinnovations.com/AuraConfigTool)

TRANSMITTER CONFIGURATION GUIDE		
	Spektrum, Futaba & Graupner	JR DMSS <sup>1</sup>
Wing/Tail Type	1 Aileron, 1 Elevator, 1 Rudder	1 Aileron, 1 Elevator, 1 Rudder
End Points (Travel Adjust or ATV)	Ail/Ele/Rud <b>125%</b> <small>* For newer pilots with lower skill levels, we recommend setting the aileron end points to <b>112%</b></small>	Ail/Ele/Rud <b>88%</b> <small>* For newer pilots with lower skill levels, we recommend setting the aileron end points to <b>75%</b></small>
	Thro/Gear <b>100%</b>	Thro/Gear <b>88%</b>
Reversing	<b>None Required<sup>2</sup></b>	<b>None Required</b>
Sub Trim	<b>Verify at zero, NOT ALLOWED</b>	<b>Verify at zero, NOT ALLOWED</b>
Trim Levers	<b>Verify at zero</b>	<b>Verify at zero</b>
CH. 5 (Gear)	<b>Assigned to a 3-position switch</b>	
CH. 6 (LEDs)	<b>Assigned to a 2-position switch</b>	
Timer <sup>4</sup>	<b>Set to 5:00 for initial flights</b>	

1. JR transmitter users that use Spektrum DSM2/DSMX receivers should follow the Spektrum information in the chart above.
2. If you are using a Futaba transmitter, please note that some Futaba transmitters have the throttle set to reversed by default. Leave reversing set to defaults to start, and reverse as needed.
3. This is only required to switch the LEDs on/off via the transmitter. If the LED controller is unplugged from the receiver or Aura 8, the lights default in the ON position when powered.
4. This aircraft can fly anywhere between 5 and 9 minutes (w/6S 5200mAh Li-Po), depending on flying style.

## NOTICE

FOR CUSTOMERS USING TRANSMITTERS OTHER THAN WHAT IS LISTED IN THE CHART ABOVE, PLEASE VISIT OUR WIKI PAGE FOR INSTRUCTIONS SPECIFIC TO YOUR TRANSMITTER AND RECEIVER BRAND

JETI	<a href="http://wiki.flexinnovations.com/wiki/Aura/JetiUse">wiki.flexinnovations.com/wiki/Aura/JetiUse</a>
HITEC	<a href="http://wiki.flexinnovations.com/wiki/Aura/HitecSbusUse">wiki.flexinnovations.com/wiki/Aura/HitecSbusUse</a>
FRSKY	<a href="http://wiki.flexinnovations.com/wiki/Aura/FrSkyUse">wiki.flexinnovations.com/wiki/Aura/FrSkyUse</a>

## CONNECTING A BATTERY/ARMING THE ESC

Observe the following procedures to safely power up your model after it has been bound. Ensure propeller is removed unless sequence is followed to power up before flight.

1. Lower the throttle stick and trim to their lowest setting and turn on the transmitter. Wait for your transmitter to indicate the radio signal is being broadcast before proceeding.

If a battery is connected to the ESC with the throttle fully open on the active transmitter, the ESC will enter programming mode. If this occurs, simply disconnect the battery, lower the throttle, and reconnect the battery.

2. Ensure the aileron, elevator and rudder gimbals are centered.
3. With the airplane on a solid surface, connect the battery to the ESC and wait. The ESC will make the motor emit a series of audible tones during its initialization process.
4. The ESC will make the motor emit a short, final tone sequence indicating that the ESC is now armed, and that the motor will spin in response to throttle stick movement.

### **! WARNING**

When making adjustments to linkages, transmitter settings or the Aura 8 flight control system, remove the propeller to guard against accidental spool up.

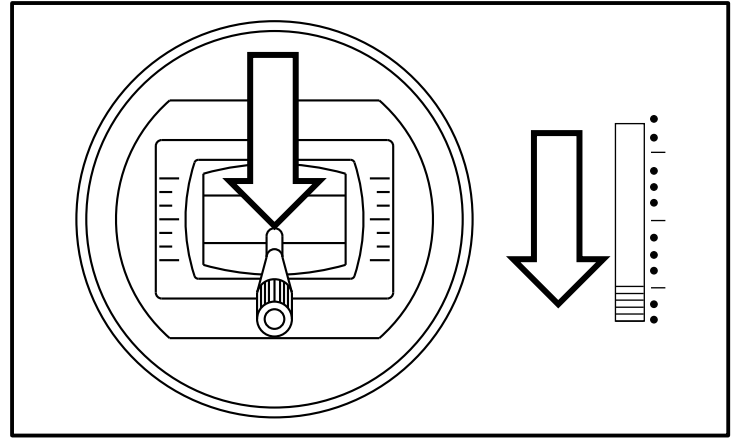

### **! CAUTION**

Always connect the battery when the throttle stick and throttle trim is in the idle/cut-off position.

### **! WARNING**

Hold the aircraft securely when connecting the battery before flight. Always ensure the propeller is clear of any and all objects as they may become entangled.

## CONNECTING A BATTERY TO THE LED CONTROLLER (NIGHT VERSION ONLY)

The LEDs on your aircraft are switchable via the transmitter, and are designed to be powered by 12 volts (3S Li-Po) through the 6S JST-XH balance tab on the LED controller. By default, the LED controller is left unplugged from the receiver or Aura.

If the servo lead of the LED controller is not plugged into the Aura or a receiver, the LEDs will default in the ON position, allowing the Night Version to be flown at night with a basic 6-channel transmitter or receiver.

The LEDs should be powered from a separate 3 cell Li-Po battery per the diagram below.

### **! WARNING**

The LEDs draw approximately 2.5A from ONLY 3 cells of the battery powering it. If using a higher cell count battery for power, 3 of the cells will have a lower voltage than the others at the end of each flight. Leave excess voltage in the battery at the end of each flight to prevent the over-discharging of the cells that power the LEDs. You MUST balance charge your batteries after each flight the LED controller is powered by anything other than a 3 cell battery.

### **! WARNING**

Do not leave the battery plugged into the LED controller for extended periods of time. Doing so can damage the battery.

**LED  
CONTROLLER**

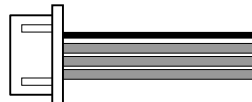
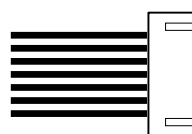

**3-6 cell Li-Po**

Note: Black wire is Negative, other wires are positive

# RECEIVER INSTALLATION/SERVO CONNECTIONS

Aura will auto-detect modern digital receiver connection(s). Using a modern digital receiver connection gives the Aura access to precise data of each channel for additional gyro-enabled outputs, simplifies wiring and allows for more advanced features. To connect a modern digital receiver connection, follow the steps on this page, then skip ahead to page 14.

## DEFAULT AURA CONNECTIONS

- S1 Throttle (ESC/BEC)
- S2 L. Aileron (BOTTOM)
- S3 L. Aileron (TOP)
- S4 R. Aileron (BOTTOM)
- S5 R. Aileron (TOP)
- S6 Elevator
- S7 Rudder
- S8 LED (CH6/Aux1)

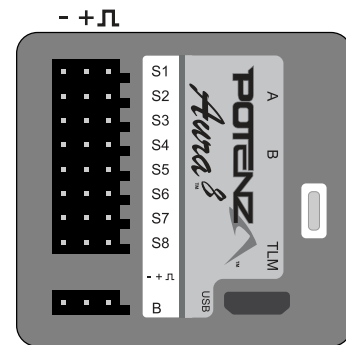

## Supported Modern Data-linked Receivers

Aura will auto-detect these modern digital receiver connections:

- Spektrum Remote Receivers      Spektrum SRXL
- Futaba or Hitec S. Bus            JR XBus (Mode B)
- Graupner HOTT (Sum D of 8)    Jeti (standard)

A PPM (8CH, negative shift, approximately 22ms/frame) receiver may also be connected into port "B", however, Aura will not auto-detect and setup must be performed through the Aura Config Tool (Windows Application)

For specific information on receiver types and our recommended receivers for this aircraft, please visit the Mamba 60 Wiki page at the below URL.

[wiki.flexinnovations.com/wiki/mamba60](http://wiki.flexinnovations.com/wiki/mamba60)

## CONNECTING YOUR RECEIVER TO AURA

### Digital receiver connections

Examples of recommended receivers:

#### Spektrum SRXL

- AR7700
- AR8010T
- AR9030T

#### JR XBus

- RG612BX
- RG712BX

#### FrSky S.Bus

- RX6R
- RX8R

#### Futaba S.Bus

- S-FHSS - R2001SB
- FASST - R6303SB
- FASSTTest - R7008SB

#### Graupner SUDM

- GR-16L

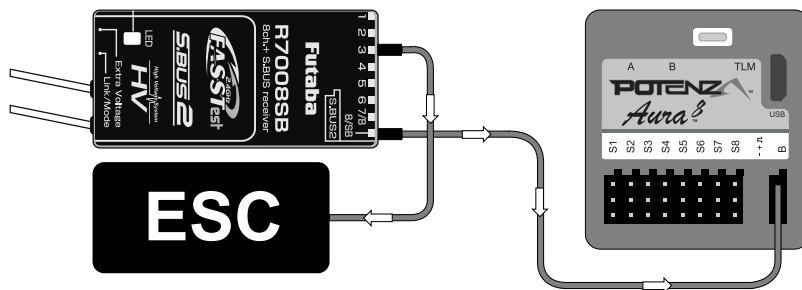

Note: If you are using Futaba S.Bus, be sure to use the proper S.Bus port in your receiver. DO NOT use the S.Bus 2 port, as it is not supported for use with the Aura 8. Refer to your manufacturer's instructions for proper S.Bus use.

1. While Spektrum and Futaba usually output their digital data stream, it may be necessary for JR DMSS, Graupner HOTT, and Jeti users to program the transmitter/receiver to output the correct digital format listed on the previous page. Consult your transmitter and receiver manuals for further details.
2. Bind your transmitter and receiver per your manufacturer's instructions.
3. Connect the included male to male servo extension to the receiver's data port (ex: S.Bus, SRXL, etc.) and connect to servo port "B" on the face of the Aura. Refer to your radio manufacturer's instructions for specific information on appropriate serial port connections and system settings.

If your receiver has a working throttle port while using its digital connection, USE IT. Move the ESC (throttle) lead from Aura port S1 to your receiver's throttle port. Consult your receiver and/or transmitter instruction manual for specific details on your system.

4. With transmitter powered, power up the aircraft. Aura will search (sweeping LEDs) and lock onto the signal. You will then see solid orange (power and calibrated sensor) plus solid green (valid radio source), and have control of the model.

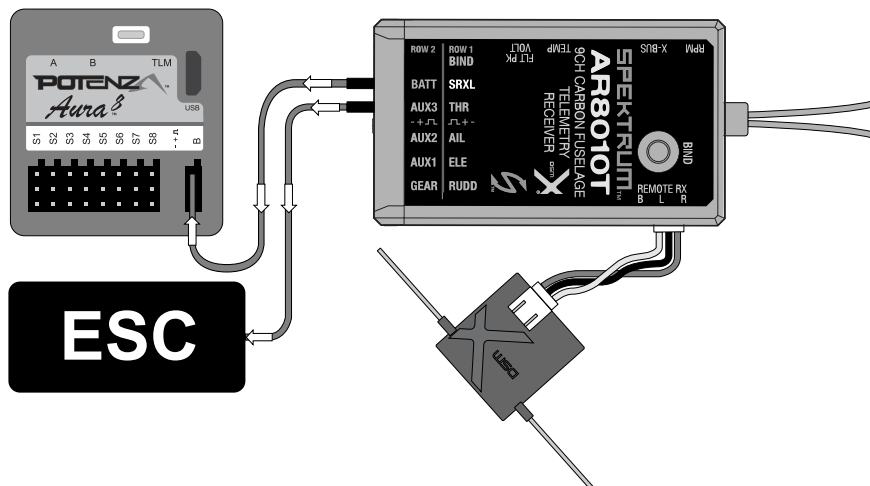

Note: When using Spektrum SRXL to connect to the Aura, always connect the remote receivers to the Spektrum receiver, NOT the Aura.

## RECEIVER INSTALLATION/SERVO CONNECTIONS (CONTINUED)

### Spektrum Remote Receivers

Please note, for optimum connection reliability and performance using Spektrum, the Flex Team HIGHLY recommends the use of a traditional receiver with SRXL (like the AR8010T or AR9030T). Remote receivers may still be used at your own risk, however.

1. Connect (2) matching Spektrum remote receivers to Mini Port 'A' and Mini Port 'B' at the top of the Aura case.
- 2A. To bind a DSMX Spektrum remote receiver connection, insert a bind plug into Aura Port S8.
- 2B. To bind a DSM2 Spektrum remote receiver connection, insert a bind plug into Aura Port S1 AND S8.

If you are unsure which type of DSM remote receiver you have, start by attempting the bind process with a bind plug in S8. If you continue to have trouble binding, then insert one bind plug in S1, and one bind plug in S8.

3. Connect the flight battery to the ESC and the remote receivers will begin to flash, indicating that they are ready to bind. Follow the instructions provided with your transmitter to complete the bind process.
4. Once bound (indicated by both remote receivers showing a solid orange LED), Aura will begin the Auto-Detect process, indicated by sweeping LEDs on the Aura. Once complete, you will see a solid orange (power and calibrated sensor) and solid green (Aura receiving valid receiver data) LED, indicating that the Aura is in its flight ready state.
5. Mount your receivers using double sided foam tape or hook and loop tape. Consult your receiver manual for proper mounting orientations and procedures.

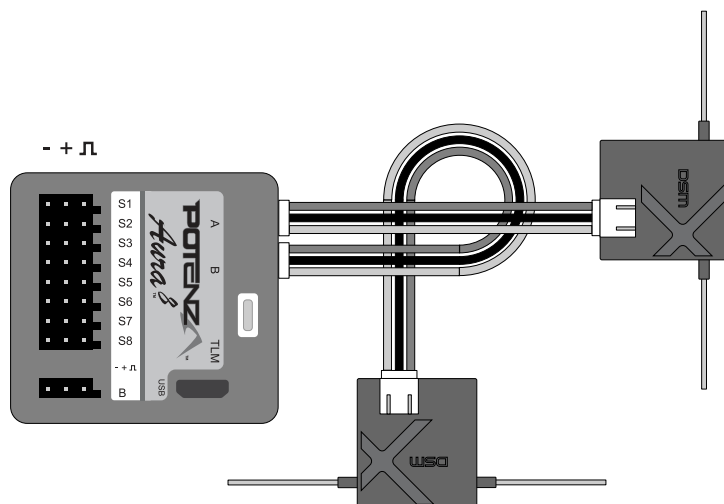

Note: It may be necessary to move the ESC lead to another open port (such as 'Port B') during the binding procedure. Be sure to return the ESC lead back to S1 after binding is complete.

Note: There are many JR-branded remote receivers that use Spektrum DSM2 and DSMX RF protocol. For these, follow the instructions as Spektrum remote receivers.

# RUDDER AND ELEVATOR LINKAGE INSTALLATION

## Required Tools and Fasteners

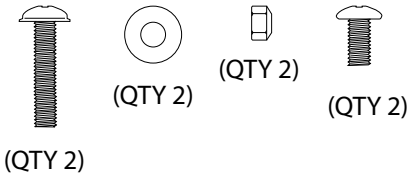

Elevator and Rudder Pushrod Assemblies  
M2x10 Phillips Head Machine Screws  
M2 Flat Washer  
M2 Lock Nut  
M3x6 Phillips Head Machine Screws

#1 Phillips Screwdriver  
#0 Phillips Screwdriver  
Needle-Nosed Pliers (or Hemostats)  
Blue Thread Lock

1. Locate the Elevator and Rudder pushrod assemblies.
2. Power on your transmitter, move the flight mode switch(assigned on page 9 of this manual) to Mode 1 (Gyro off). Power on the airplane. Confirm the Aura is in Mode 1 by rotating the airplane quickly and verifying that you get no gyro controlled movement.
3. With the aircraft still powered on, install the rudder and elevator servo arms perpendicular to the servo case, being sure to orient the servo arm towards the bottom of the fuselage. **Apply a small amount of Blue Thread Lock** to the M3x6 Phillips head machine screw and secure the servo arm in place with a #1 Phillips screwdriver.

## ⚠ WARNING

DUE TO VARIANCES IN PRODUCTION AND THE LARGE CONTROL SURFACE THROWS ON THIS AIRCRAFT PROPER SERVO CENTERING AND TRAVEL ADJUSTMENT IS CRITICAL TO PREVENT SERVO OVER TRAVEL AND FAILURE. IF THE SERVO ARMS ON YOUR AIRCRAFT DO NOT SIT PERPENDICULAR TO THE SERVO CASE, YOU MUST USE THE AURA CONFIG TOOL TO ADJUST THE SUB-TRIM AND/OR OUTPUT SCALE VALUES TO PREVENT OVER TRAVEL OF THE SERVOS.

To download the Aura Config Tool, please visit:  
<https://www.flexinnovations.com/articles.asp?ID=257>

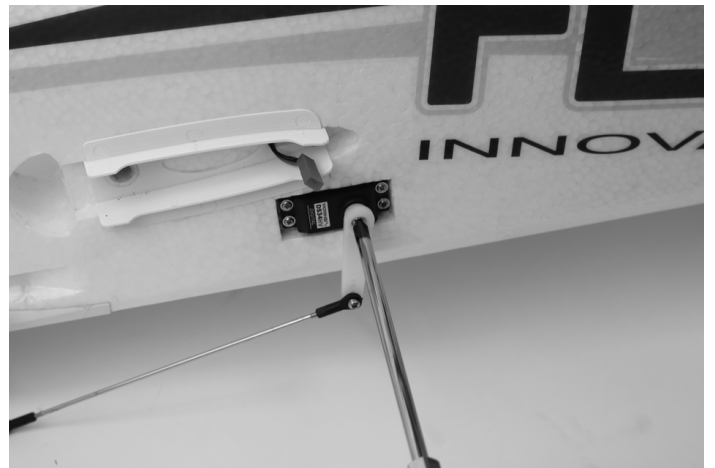
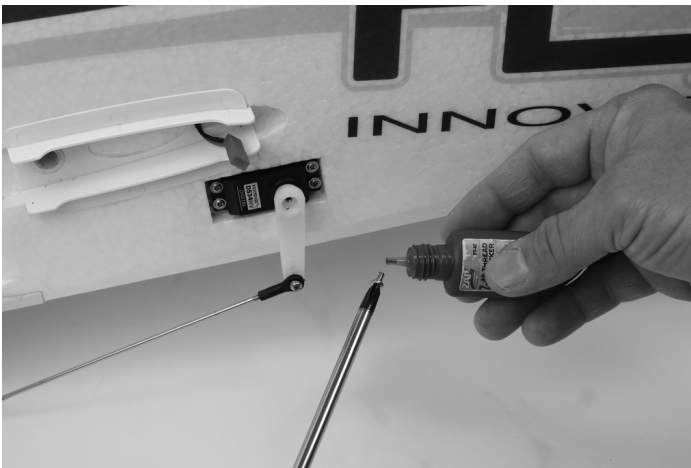

## RUDDER AND ELEVATOR LINKAGE INSTALLATION (CONTINUED)

4. Use a #0 Phillips screwdriver, M2x10 machine screw, M2 washer and M2 lock nut to secure the linkage to the control horn. Use the chart below to ensure proper control horn and servo arm linkage locations. The order of compents are as follows.

### Required Fasteners

M2x10 Phillips Head Machine Screw  
M2 Flat Washer  
Servo Arm or Control Horn  
M2 Lock Nut

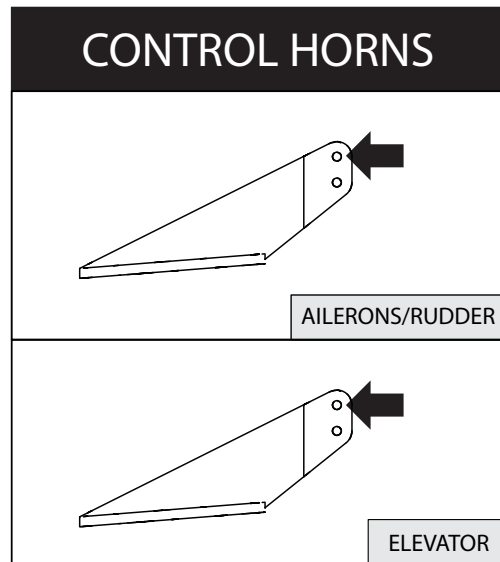
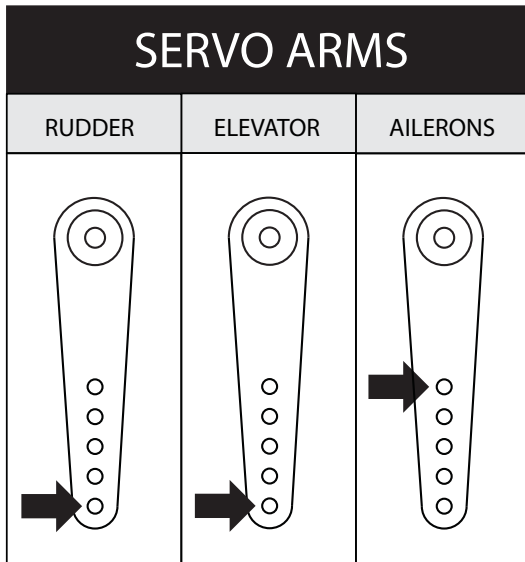

## HORIZONTAL STABILIZER INSTALLATION

---

### Required Tools and Fasteners

- (4) Clear Mounting Tape
- Carbon Stab Tube

1. Locate both horizontal stabilizer and elevator assemblies, stabilizer tube, and the provided clear tape ( to secure stabilizers to fuse).
2. Slide the horizontal stabilizer tube into the fuselage (approximately centered).
3. Slide the left and right stabilizer-elevator assemblies onto the tube. Ensure the control horn orients the bottom of fuselage and that the elevator joiner tabs are indexed properly. (Be sure to connect the JST connector for the stab spot lights as you slide the stabilizer into place.  
\* (NIGHT version only.) **DO NOT FORCE STABILIZERS INTO PLACE**
4. Apply a piece of the clear tape to each joint (top and bottom) between the stabilizer and the plastic mount on the fuselage.





# MAIN WING INSTALLATION

## Required Tools and Fasteners



M2.5x8 Phillips Head Self-Tapping Screws

#1 Phillips Screwdriver  
Medium (150) Grit Sandpaper  
Low Tack Tape  
15 Minute Epoxy  
Isopropyl Alcohol

1. Locate the fuselage, top wing center section, the (4) carbon tubes (cabane struts), and the (8) M2.5x8 Phillips head self-tapping screws.  
**\* The long carbon tubes are the rear cabane struts and the short carbon tubes are the front cabane struts.**
2. Dry fit the cabane struts into the plastic mounts on fuselage and wing center section. Install the cabane struts by aligning the pre-drilled holes in the tubes and in the plastic mounts on fuselage and wing. Temporarily install the M2.5x8 Phillips head self-tapping screws to make sure the struts are in the proper location. Now that you have the top wing center section pre-installed, use low tack tape around the exposed area of the cabane struts to mark area to be glued and to protect the exposed part of the strut from excess glue.

## NOTICE

**WE RECOMMEND THAT ALL ENDS OF THE CABANE STRUTS BE GLUED (TO WING AND FUSELAGE) WITH 15 MINUTE EPOXY IN ADDITION TO THE (8) M2.5X8 PHILLIPS HEAD SELF-TAPPING SCREWS BEING INSTALLED IN EVERY JOINT TO WING AND FUSELAGE. IF STORAGE AND/OR TRANSPORTATION IS AN ISSUE, ONLY USING SCREWS (NO GLUE) IN BOTTOM (FUSELAGE) JOINTS IS AN OPTION TO MAKE THE CENTER SECTION REMOVABLE.**

3. Remove center section from fuselage (leaving the struts mounted to the wing) the using medium (150) grit sandpaper, scratch up the exposed area on the bottom of each cabane strut and then clean the struts and fuselage strut mounts with isopropyl alcohol.
4. Glue the cabane struts into the mounts on the fuselage with 15 minute epoxy and install the (4) M2.5x8 Phillips head self-tapping screws in the bottom of the cabane struts. Remove tape and clean up any excess glue. Repeat process for the top of the cabane struts.



## MAIN WING INSTALLATION (CONTINUED)

---

### Required Tools and Fasteners



(QTY 4)

M3x10 Phillips Head Machine Screw  
(4) Interplane strut retaining pins

#1 Phillips Screwdriver

5. Locate the lower wing panels, the short wing tube, and the M3x20 Phillips head machine screws.
6. Slide the wing tube through the fuselage then slide one of the wing panels onto the wing tube and connect the servo leads. It is good idea at this time to install the M3x20 Phillips head machine screw in the first wing panel so it doesnt slide out when installing second wing panel
7. Mount the second lower wing panel like the first
8. Locate the long wing tube, the M3x25 Philips head machine screws, and both top wing panels.
9. Slide the wing tube through the center section of the upper wing, slide one of the wing panels on, connect the servo leads and install the M3x25 Phillips head machine screw. Repeat for other wing panel.
10. Now that both wings are installed, locate the (2) interplane struts (or "I" struts if you prefer) and the four "I" strut retaining pins.
11. Slightly flex the wings apart and put one of the Interplane struts in place, insert retaining pin into L.E. into the pre-drilled hole at base and top of the "I" strut. Slide the pins in to the point where you feel them "pop" into place. Rotate the pins so that the exposed part is resting on the wing. Repeat for other side. (see page 19)



## MAIN WING INSTALLATION (CONTINUED)

---



# PROPELLER, SPINNER, AND BAFFLE INSTALLATION

## Required Tools and Fasteners

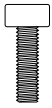

(QTY 4)



(QTY 1)

M3x10 Socket Head Machine Screw  
M3x10 Phillips Head Machine Screw  
Prop Adapter  
Prop Nut

Adjustable Wrench  
#1 Phillips Screwdriver  
15 Minute Epoxy  
Blue Thread Lock

1. Locate the motor baffle, prop adapter and propeller nut.
2. Place propeller adapter on front of motor. Apply a small amount of Blue thread lock on each of the four M3x10 socket head screws. Install them through the prop adapter and to the motor.
3. Locate the motor baffle and dry fit it in the front of the fuselage. Once you ensure it fits properly, remove it and use 15 minute epoxy on the baffle and re-install it into the front of the fuselage. Wipe away any excess glue and allow to cure.
4. Locate the propeller, propeller nut, and spinner. Install the propeller on to the propeller adapter with the convex side facing forward. Place the propeller washer over the shaft and thread the propeller nut on to the propeller adapter. Use an adjustable wrench to tighten the propeller nut.
5. Place the spinner over the prop shaft (propeller adapter), align the notches in spinner with the propeller blades and secure the spinner with the M3x10 Phillips head screw and a #1 Phillips screw driver.

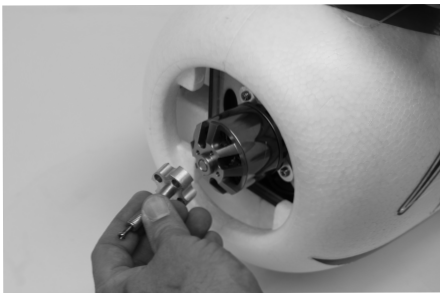

## BATTERY INSTALLATION

---

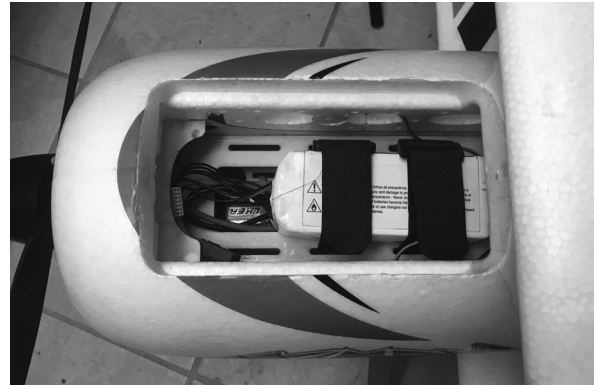
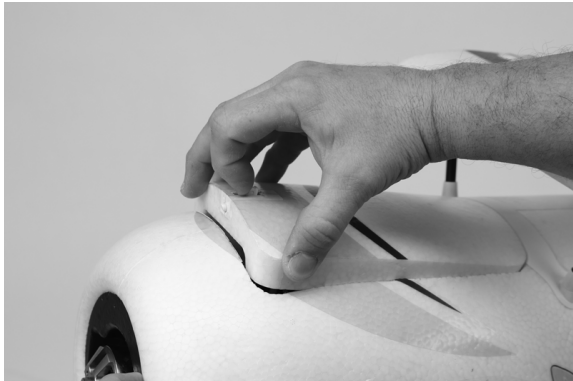

### ⚠ CAUTION

Always keep limbs clear from the propeller when the battery is connected. After the ESC arms, the propeller will rotate when the throttle is moved. Unlike an internal combustion engine, electric motors apply more voltage to counteract resistance, therefore any object that is entangled in the propeller will be severely damaged before the motor will stop

### ⚠ WARNING

**When making adjustments to linkages, transmitter settings, or the Aura 8 flight control system, remove the propeller to guard against accidental spool up.**

## CENTER OF GRAVITY VERIFICATION

---

 **C.G.** is between 2-11/32" and 2-5/8" (60-70mm) from Leading Edge of Bottom Wing

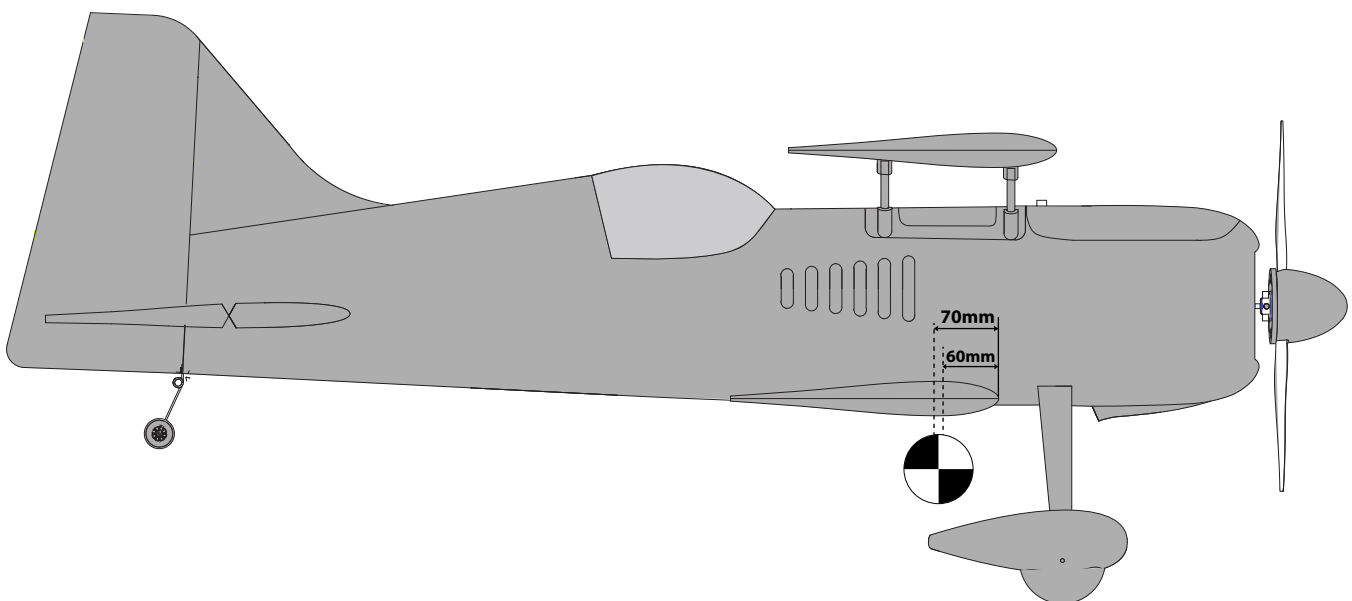

# CONTROL DIRECTION TEST

Refer to the chart below to determine the proper control surface directions.

If controls are reversed, DO NOT REVERSE CONTROLS IN TRANSMITTER OR IN THE AURA CONFIG TOOL. Email us at support@flexinnovations.com for corrective action. Note that BOTH the Transmitter Control Direction Test AND the Flight Controller Sensor Direction Test **MUST BOTH BE PASSED! IF ONE DOES NOT PASS, DO NOT FLY!**

NOTE: There is pre-configured rudder to aileron and rudder to elevator mixing programmed into the Aura. Simultaneous movement of these control surfaces with rudder input is intentional and completely **NORMAL**.

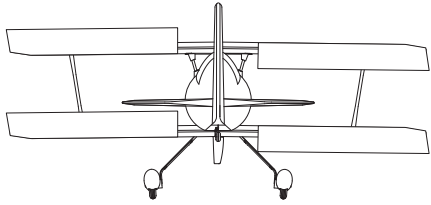
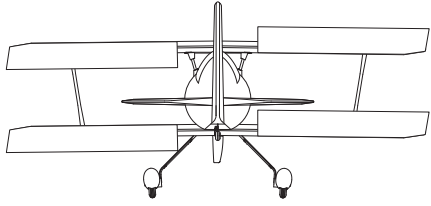
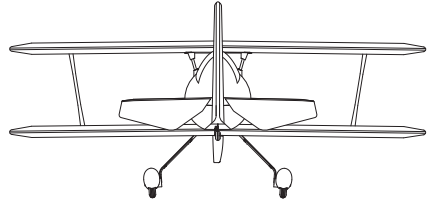
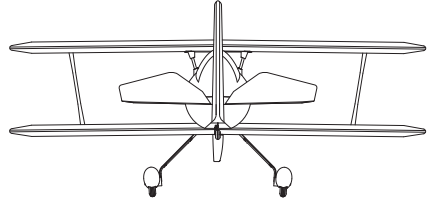
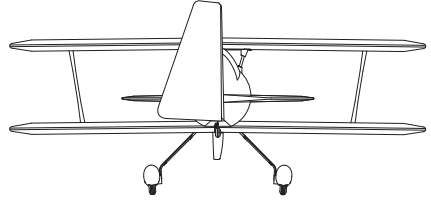
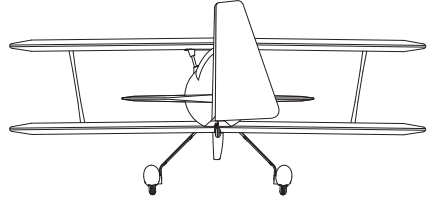
	Transmitter Command	Proper Control Surface Deflection
AILERON	Stick Left	
	Stick Right	
ELEVATOR	Stick Forward	
	Stick Aft	
RUDDER	Stick Left	
	Stick Right	

# FLIGHT CONTROL SENSING DIRECTION TEST

Perform a test of the gyro system to verify the corrections made for a given movement are correct. If any of the tests do not result in the correct reaction from the airplane's gyro system, **DO NOT FLY THE AIRPLANE, and contact us via email at support@flexinnovations.com**

The flight control system activates with RF broadcast. Perform these tests in Mode 3 (higher gain) for better visibility and then in Mode 2, and any other modes that have gyro gains assigned. (By default, Mode 1 has no gain assigned.). Control surface deflections are exaggerated in the drawings below for clarity. Please note, that the control surfaces will move **ONLY** when the aircraft is being **ROTATED**.

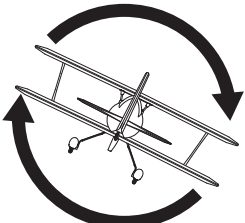
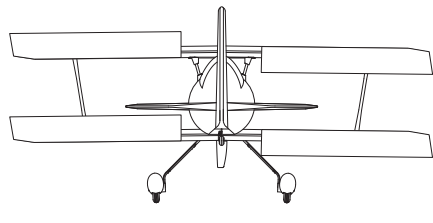
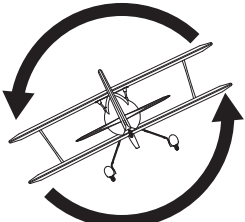
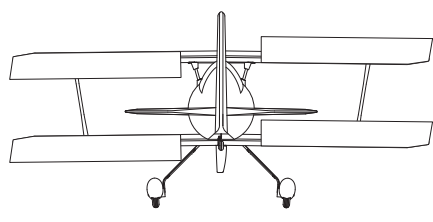
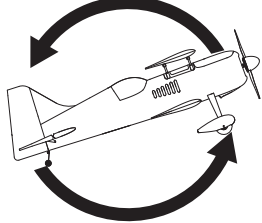
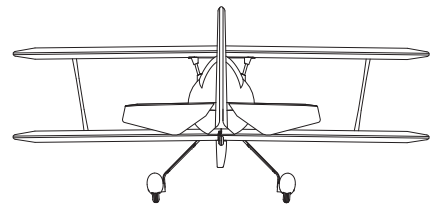
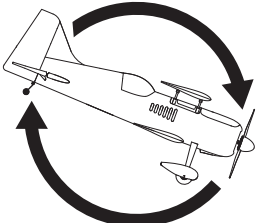
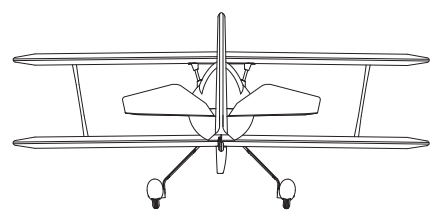
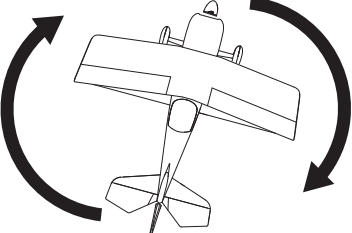
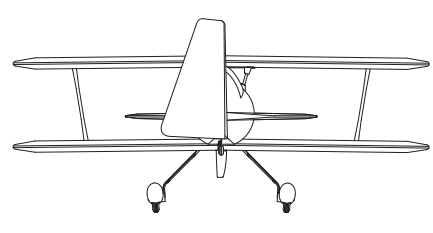
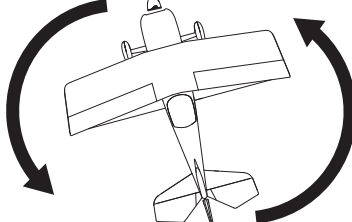
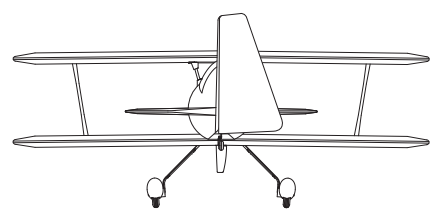
	Aircraft Movement	Proper Control Surface Deflection
AILERON		
		
ELEVATOR		
		
RUDDER		
		

## PRE-FLIGHT CHECKS

---

To help ensure a successful first flight, as well as many flights after, perform a few simple pre-flight checks to be sure the aircraft is ready to fly.

1. Verify all control surfaces are properly hinged and are in good working order. Pinch a control surface between your thumb and fore finger and stabilize the wing with your other hand. Give the control surface a good pull away from the wing. The control surface should not come unhinged from the wing. Be sure to avoid over-stressing the part as an aggressive pull may cause the control surface to come unhinged even though it was hinged properly. If hinging is loose, DO NOT FLY! Apply thin CA to the loose side(s) of the hinged to re-secure.
2. Verify that all hardware and other aircraft parts are properly secured, including those connections that require blue thread lock. This includes hardware and parts installed by the factory.
3. Verify your battery is fully charged and in good condition. Avoid using batteries with swollen cells, or batteries that do not charge back to their full capacity.
4. Verify the C.G. is in the proper location and the battery is secured in place.
5. Ensure the Aura is on and functioning properly. Power on your transmitter, followed by the aircraft. Ensure the Aura is calibrated properly and receiving a valid radio source (solid orange+solid green LEDs).
6. Verify transmitter stick inputs result in the proper control surface movements (reference page 22) and that Aura flight modes work properly.
7. Verify aircraft movement results in proper Aura sensor corrections (reference page 23).
8. Verify the motor and ESC function properly. Point the aircraft in a safe direction, and away from any objects or limbs that could become entangled in the propeller. Hold the airframe firmly from behind the aircraft. Smoothly advance the throttle to full and back to idle. Listen and watch for any odd or unusual behavior for the motor or speed control.



# FLYING YOUR MAMBA 60

## Selecting a Flying Site

Selecting a flying site is critical to a successful flight. Airplanes require a lot more room than other R/C products, therefore, a neighborhood or parking lot is less than ideal. A large open field with short grass and generous overfly area are the best candidates if no AMA field is available in your area. Know your overfly area - ensure that there are no houses, playgrounds, or other buildings that may be damaged if the airplane were to crash.



## Takeoff

Taxi or place the aircraft on the runway centerline, with the nose into the wind. Select Mode 2, then set throttle trim such that the motor spins over smoothly at its lowest RPM without stopping. Smoothly advance to full throttle while maintaining directional control with the rudder and slight back pressure on the elevator. The airplane should lift off gently before the throttle is fully open. Altitude is your friend on the first flight. Briskly climb to a safe altitude and trim the airplane out. Remain in mode 2 until the aircraft is fully trimmed and you are comfortable with its handling. The airplane should fly straight and level at 1/2 to 3/4 power with no hands on the transmitter. If more than a few clicks of trim are required, land and follow the special trimming instructions.

## Flying

Try some basic maneuvers and slowly progress into the airplane's flight envelope as you become more comfortable with the airplane's flight qualities and perfect your setup. At a safe altitude, try the other flight modes as desired. **Note: If at any time, such as after gain adjustments, you experience unexpected control system inputs or oscillations, switch to Mode 1, and land and troubleshoot the issue. (Mode 1 turns the sensor inputs off with default programming)**

## Landing

Be mindful of your flight time and allow adequate battery reserve for a couple of go-arounds, if necessary, on the first few flights. Select Mode 2 and slow the airplane and align with the runway, into the wind. The airplane should descend smoothly in this configuration with proper airspeed. Once you are close to the ground, gradually close the throttle fully and begin to smoothly apply up elevator as required to arrest descent and the airplane should gently touch down with a short roll out.



### CAUTION

USE CAUTION WHEN FLYING YOUR MAMBA 60E+ IN MODE 3 AT HIGH AIRSPEEDS. DOING SO CAN INDUCE CONTROL SURFACE OSCILLATIONS AND MAY CAUSE A CRASH.

## Trimming

The first several flights on your new Mamba 60E+ should be dedicated to trimming and setup. Fly the airplane at 2/3 power in Mode 2 and trim for level flight. Land, adjust linkages and return the trim and/or subtrim to zero and fly again. Repeat process until the airplane flies hands off, straight and level.

Transmitter trim or sub-trim will cause trim shifts when different flight modes are selected. To eliminate this trim shift, the model should be mechanically trimmed, or Aura "Quick Trim" may be used instead.

## Aura Quick Trim

The Aura 8 features a Quick Trim Mode that eliminates the need for mechanical linkage adjustments during test flights. Aura will learn the trim values from your transmitter, and apply them to the control surfaces after power up when enabling quick trim mode.

NOTE: Quick Trim can also be used BEFORE flying to make small changes to center the control surfaces before flight.

1. Fly the airplane in Flight Mode 2. Trim the aircraft with the transmitter and land. **DO NOT CHANGE FLIGHT MODES.**
2. Power off the Mamba 60E+. Remove the servo lead plugged into Aura Port S3 and insert bind plug. Confirm that the transmitter is powered on and repower the Aura
3. Wait 5 seconds for the Aura to completely initialize. Confirm Quick Trim mode is active by checking the Blue LED is slowly flashing.
4. Remove the bind plug from **Aura Port S3**, and re-install the servo that was previously removed into S3. Removing the bind plug stores the current trims in the Aura. The Blue LED will flash quickly after control surface trim values are stored. While the trim values are stored in Aura, they are not applied to the control surfaces until the aircraft is repowered.
5. Remove power from the Mamba 60E+ and center all control surface trims on the transmitter.
6. Repower the Mamba 60E+. The control surfaces should be unchanged even though the trim has been centered on the transmitter.
7. Switch between other Flight Modes to ensure you do not see

NOTE: QUICK TRIM MAY BE REPEATED AS NEEDED FOR FINE TUNING, OR IF CHANGES TO THE AIRCRAFT ARE MADE.

NOTE: ENSURE AILERON/ELEVATOR/RUDDER SUB-TRIMS ARE ZERO BEFORE FLYING FOR QUICK TRIM PROCESS

NOTE: QUICK TRIM IS NOT AVAILABLE TO PWM CONNECTION USERS. IF YOU ARE USING A PWM CONNECTION TYPE, YOU WILL NEED TO MECHANICALLY TRIM THE MODEL

## ADVANCED MAMBA 60 AURA CONFIGURATION

The Aura 8 installed in your Mamba 60 is equipped with two possible Aura configurations - Stock and Expert. These may be accessed **WITHOUT THE USE OF A WINDOWS BASED PC OR TABLET** by using the Aura quick set feature. The "Expert" version offers three flight modes: Sport, High Speed, and Slow Speed 3D.

### Flight Mode 1 - Sport

For sport or precision aerobatics.

Rates are low, expo adjusted for smooth flight.

Gains are set low.

### Flight Mode 2 - High Speed 3D

For high speed flying (full throttle) at high rate. Ideal for tumbling and high energy aerobatics.

Rates are high, expo adjusted high for smooth flight.

Gains are set low

### Flight Mode 3 - Slow Speed 3D

Ideal for "high-alpha" flight. Ideal for harriers, hovering, and other slow speed flight.

Rate in all control surfaces at max, expo adjusted for smooth flight

Gains are set high.

#### CROW

Note: "**Crow**" (when top ailerons deflect up and bottom ailerons deflect down) is accessed when Aura is configured to "Expert" mode only.

In order to switch crow on and off, assign CH7/Aux2 to a 2 position switch on your transmitter. Test the switch action on your transmitter's monitor screen.

Crow is mixed in a linear fashion to the throttle. With crow activated, advancing throttle to full will return the crow to zero. When the throttle is returned to idle, crow is once again activated

Note: Flight mode 3 should not be used to fly the airplane at high speed.

**Control surface oscillation might occur if the airplane is flown at high speed in this mode.**

## TURNING ON "EXPERT" MODE IN AURA

1. Make sure all power is removed from the Mamba 60E+. Remove the propeller for safety.
2. Turn on your transmitter. Ensure you are in the correct model memory.
3. Remove the servo lead that is in Aura Port S2.
4. Insert a bind plug into Aura Port S2
5. Power the Mamba 60E+ by plugging a battery into the ESC. The LEDs on the Aura will repeatedly double flash orange. This confirms you have entered Quick Set Mode. The Green LED may be flashing, or solid. More information regarding the Green LED is below.
6. Use the Gear (CH5) switch (assigned earlier for Aura Flight Modes) to select the Expert or Stock Aura configurations.  
  
If the Green LED on the Aura is **SOLID**, the Aura is set to use the **STOCK** configuration.  
  
If the Green LED on the Aura is **FLASHING**, the Aura is set to use the **EXPERT** configuration.
7. Once you have selected your configuration, simply remove the bind plug from S2. All LEDs on Aura will be on while Aura is saving the settings. Once saved, the Aura will go back to it's previous LED configuration from step 6. Power off the airplane and Aura, and replace the servo lead back into Aura Port S2.
8. Verify that all controls function, and that both transmitter direction test and Aura sensor test pass. Familiarize yourself with the new flight modes and their relative switch positions, and enjoy flying with your new flight modes!

The Expert program is gyro-enabled in all flight modes. If you wish to use a secondary switch to be able to turn Aura off, we recommend using the Wizard in the Aura Config Tool, and setting up a Gyro Kill switch

For more information on how to access the Expert program via the Aura Config Tool, please visit:

[wiki.flexinnovations.com/wiki/Mamba60](http://wiki.flexinnovations.com/wiki/Mamba60)

# AIRCRAFT TROUBLESHOOTING GUIDE

Should you encounter any abnormal situations with your Mamba 60E+, refer to the matrix below to determine the probable cause and a recommended solution for the action.

If the required solution does not rectify the problem, please contact product support for further assistance.

## NOTICE

Unless specifically required, ALWAYS troubleshoot the airplane with the propeller removed.

DISCREPANCY	PROBABLE CAUSE	RECOMMENDED SOLUTION
Motor nonresponsive (ESC initialization tones audible)	Throttle not at idle and/or throttle trim too high	Lower throttle stick and trim completely. If problem persists, ensure that the sub-trim and travel adjust are properly set in the radio's programming.
	Throttle channel is reversed	Reverse throttle channel in radio programming
Motor nonresponsive (no ESC initialization tones audible)	Motor disconnected from ESC	Ensure plugs are fully seated. Check battery and/or plugs for damage and replace any damaged components found - DO NOT ATTEMPT REPAIR
Motor turns in the wrong direction	The three motor wires are connected incorrectly to the ESC	Swap any TWO motor wires.
Reduced flight time or aircraft underpowered	Flight battery not fully charged	Ensure battery is fully charged prior to installing in aircraft
	Propeller installed backwards	Install propeller so that the convex side faces forward (tractor configuration)
	Flight battery damaged	Remove battery from service completely and replace with a different battery
	Ambient temperature is too cold	Ensure battery packs are adequately warm (70°F/21°C) before flight
	Battery capacity too small for intended use	Replace battery with one of proper capacity and discharge capacity (C rating)
	ESC reaching preset LVC (low-voltage cutoff)	Recharge flight battery or reduce flight time
	Battery is too weak or damaged	Check battery's physical condition, check battery voltages after charge
Excessive propeller noise and/or vibration	Battery's discharge rating may be too small	Replace battery with one with higher 'C' rating
	Damaged spinner and/or propeller, collet, or motor	Replace damaged components - DO NOT ATTEMPT REPAIR
	Propeller is not balanced	Balance or replace the propeller
	Prop nut is loose	Tighten prop nut with appropriate-sized wrench
	Spinner is not fully in place or tightened	Loosen the spinner bolt, adjust as required, retighten spinner bolt
Control surfaces nonresponsive	Propeller nut or propeller adapter threads not cut straight	Replace propeller nut or propeller shaft - DO NOT ATTEMPT REPAIR
	Airframe or control linkage system damage	Examine airframe for damage, repair as required; inspect control linkage system (servo, pushrod, control horn) for damaged components and replace as required
	Wire damaged or connector loose	Examine wires and connections, replace as necessary
	Transmitter bound incorrectly, incorrect active model memory, incorrect Aura data input configuration, incorrect Aura transmitter settings	Consult radio manual for proper binding and model selection instructions
	Battery voltage too low	Use volt meter to check battery; recharge or replace as necessary
	Battery disconnected from ESC	Check that the EC3 plugs are fully seated
	BEC (battery elimination circuit) damaged	Replace ESC - DO NOT ATTEMPT REPAIR
Failed control direction test	Damaged Servo	Replace Servo - DO NOT ATTEMPT REPAIR
Controls reversed	Incorrect Aura 8 or Transmitter Setting - DO NOT FLY!	Reference transmitter and receiver sections of this manual. If no solution found, contact customer support at <a href="mailto:support@flexinnovations.com">support@flexinnovations.com</a>
	Aura 8 or transmitter settings incorrect	Refer to control surface direction chart and transmitter setup; adjust appropriate settings as required. Check Mamba 60E+ and Aura wiki web pages for additional information. Contact customer support at <a href="mailto:support@flexinnovations.com">support@flexinnovations.com</a>
Control surface oscillation	Exceeding maximum airspeed for configuration	Reduce airspeed
	Gains too high for aircraft/flight configuration	Refer to Aura 8 manual to decrease desired control surface gain
	Propeller/spinner not balanced	Balance or replace propeller and/or spinner
	Motor vibration	Inspect motor mounting bolts and re-tighten as necessary
	Loose Aura 8 mounting	Re-align and secure the Aura 8 to the aircraft
	Control linkage slop	Examine control system and repair or replace work components
	Improper transmitter setup	Refer to Aura 8 manual to correctly configure transmitter
	Damaged propeller or spinner	Replace damaged component- DO NOT ATTEMPT REPAIR
Trim changes between flight modes	Improperly set master gain	Ensure master gain is set for proper gain value
	Trims are not properly zeroed	Readjust control linkage and re-center trims in radio
	Sub-trim is not properly zeroed	Remove sub-trim; adjust the servo arm or clevis to achieve proper geometry
Trim changes between flight modes	Transmitter is not properly calibrated (aileron/elevator/rudder are not neutral with sticks centered; reference transmitter monitor	Calibrate transmitter (reference manufacturer's instructions, or return to manufacturer for calibration

## AIRFRAME REPAIRS

---

The Mamba 60E+ is molded from durable EPO foam and is repairable with most adhesives. Similar to building and repairing wood or composite airplanes, the correct glue for a given application is critical to the repair holding and not breaking again. For major repairs, such as a broken fuselage, epoxy is preferred because it allows time to correct any misalignment. For smaller repairs, such as a cracked control surface or small chunk of material missing from the airframe, regular CA is very effective. The use of odorless (foam safe) CA is not recommended on EPO foam aircraft because it is weaker than regular CA and takes a longer period of time to cure and the bond tends to be weaker.

**NOTE:** Avoid the use of CA accelerant in repairs. It can damage paint and will weaken the bond of the glue. If CA accelerant is used, be mindful of the locations of CA to prevent premature bonding of parts, or bonding a hand or clamp to the airframe.

If a part is damaged too badly to be repaired, please refer to the front of the manual for a complete listing of spare airframe parts.

**NOTICE:** If a crash is imminent, fully reduce the throttle to prevent further damage to the power system and reduce energy to lessen impact damage. Never allow the propeller to contact the ground under power, even idle.

***BE ADVISED THAT CRASH DAMAGE IS NOT COVERED UNDER ANY PRODUCT WARRANTY.***

Avoid keeping the airplane in direct sunlight when not flying. Excessive heat can damage the airplane's structure and UV damage can permanently discolor decals.

## REPLACING SERVOS

---

### **Required Tools and Fasteners:**

#1 Phillips Screwdriver

1. Unplug the servo from the receiver.
2. Unscrew the servo arm from the servo and remove the servo arm.
3. Unscrew the mounting screw located at each end of the servo and remove.

## SERVICING THE POWER SYSTEM

---

### **Required Tools and Fasteners:**

#1 Phillips Screwdriver, 13mm box wrench

1. Remove the propeller and spinner assembly from the motor.
2. Remove the (4) bolts holding the motor to the firewall using a #1 Phillips screwdriver. Disconnect the motor from the ESC.
3. To remove the ESC, simply unplug its lead from the receiver or Aura and the output leads from the motor.

# LIMITED WARRANTY

## Warranty Coverage

Flex Innovations, LLC. and its authorized resellers ("Flex") warrant to the original purchaser that the product purchased (the "Product") it will be free from defects in materials and workmanship at the date of purchase.

## Outside of Coverage

This warranty is not transferable and does not cover:

- (a) Products with more than 45 days after purchased date.
- (b) Damage due to acts of God, accident, misuse, abuse, negligence, commercial use, or due to improper use, installation, operation or maintenance
- (c) Modification of or to any part of the Product.
- (d) Product not compliant with applicable technical regulations.
- (e) Shipping damage.
- (f) Cosmetic damage

**OTHER THAN THE EXPRESS WARRANTY ABOVE, FLEX MAKES NO OTHER WARRANTY OR REPRESENTATION, AND HEREBY DISCLAIMS ANY AND ALL IMPLIED WARRANTIES, INCLUDING, WITHOUT LIMITATION, THE IMPLIED WARRANTIES OF NONINFRINGEMENT, MERCHANTABILITY AND FITNESS FOR A PARTICULAR PURPOSE. THE PURCHASER ACKNOWLEDGES THAT THEY ALONE HAVE DETERMINED THAT THE PRODUCT WILL SUITABLY MEET THE REQUIREMENTS OF THE PURCHASER'S INTENDED USE.**

## Purchaser's Solution

Flex's sole obligation and purchaser's sole and exclusive remedy shall be that Flex will, at its option, either (i) service, or (ii) replace, any Product determined by Flex to be defective. Flex reserves the right to inspect any and all Product(s) involved in a warranty claim. Service or replacement decisions are at the sole discretion of Flex. Proof of purchase is required for all warranty claims. **SERVICE OR REPLACEMENT AS PROVIDED UNDER THIS WARRANTY IS THE PURCHASER'S SOLE AND EXCLUSIVE REMEDY.**

## Limitation of Liability

**FLEX SHALL NOT BE LIABLE FOR SPECIAL, INDIRECT, INCIDENTAL OR CONSEQUENTIAL DAMAGES, LOSS OF PROFITS OR PRODUCTION OR COMMERCIAL LOSS IN ANY WAY, REGARDLESS OF WHETHER SUCH CLAIM IS BASED IN CONTRACT, WARRANTY, TORT, NEGLIGENCE, STRICT LIABILITY OR ANY OTHER THEORY OF LIABILITY, EVEN IF FLEX HAS BEEN ADVISED OF THE POSSIBILITY OF SUCH DAMAGES.**

Further, in no event shall the liability of Flex exceed the individual price of the Product on which liability is asserted. As Flex has no control over use, setup, assembly, modification or misuse, no liability shall be assumed nor accepted for any resulting damage or injury. By the act of use, setup or assembly, the user accepts all resulting liability. If you as the purchaser or user are not prepared to accept the liability associated with the use of the Product, purchaser is advised to return the Product immediately in new and unused condition to the place of purchase.

## Law

These terms are governed by Florida law (without regard to conflict of law principals). This warranty gives you specific legal rights, and you may also have other rights which vary from state to state. **FLEX RESERVES THE RIGHT TO MODIFY THIS WARRANTY AT ANY TIME WITHOUT PRIOR NOTICE.**

## Questions & Assistance

Visit <http://www.flexinnovations.com/flex-authorized-reseller> for customer support in your region.

## Inspection or Services

If this Product needs to be inspected or serviced and is compliant in the region you live and use the Product in, please contact your regional Flex authorized reseller. Pack the Product securely using a shipping carton. Please note that original boxes needs to be included, but are not designed to withstand the rigors of shipping without additional protection. Ship via a carrier that provides tracking and insurance for lost or damaged parcels, as Flex is not responsible for merchandise until it arrives and is accepted at our facility.

## Warranty Requirements

For Warranty consideration, you must include your original sales receipt verifying the proof of purchase date. Provided warranty conditions have been met, your Product will be replaced free of charge. Shipping charges are as follow: to Flex by customer, Flex out it is by Flex. Service or replacement decisions are at the sole discretion of Flex.

## COMPLIANCE INFORMATION FOR THE EUROPEAN UNION

 **Declaration of Conformity** (In accordance with ISO/IEC 17050-1)

Product(s): Mamba 60E+ Super PNP  
Item Number(s): FPM3970A, FPM3970B, FPM3870A, FPM3870B

Mamba 60E Day Red  
Mamba 60E Day Yellow  
Mamba 60E Night Red  
Mamba 60E Night Yellow

The object of declaration described above is in conformity with the requirements of the specifications listed below, following the provisions of the EMC Directive 2004/108/EC.

**EN 55022: 2010+AC: 2011**  
**EN 55024: 2010**  
**EN 61000-3-2: 2006+A2:2009**  
**EN 61000-3-3: 2013**

**EN 61000-6-3: 2007/A1:2011**  
**EN 61000-6-1: 2007**



Instructions for disposal of WEEE by users in the European Union

This product must not be disposed of with other waste. Instead, it is the user's responsibility to dispose of their waste equipment by handing it over to a designated collections point for the recycling of waste and electronic equipment. The separate collection and recycling of your waste equipment at the time of disposal will help to conserve natural resources and ensure that it is recycled in a manner that protects human health and the environment. For more information about where to drop off your waste equipment for recycling, please contact your local city office, your household waste disposal service or where you purchased the product.

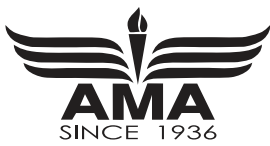

# Academy of Model Aeronautics National Model Aircraft Safety Code

## Effective January 1, 2014

A. GENERAL: A model aircraft is a non-human-carrying aircraft capable of sustained flight in the atmosphere. It may not exceed limitations of this code and is intended exclusively for sport, recreation, education and/or competition. All model flights must be conducted in accordance with this safety code and any additional rules specific to the flying site.

1. Model aircraft will not be flown:
  - (a) In a careless or reckless manner.
  - (b) At a location where model aircraft activities are prohibited.
2. Model aircraft pilots will:
  - (a) Yield the right of way to all human-carrying aircraft.
  - (b) See and avoid all aircraft and a spotter must be used when appropriate. (AMA Document #540-D.)
  - (c) Not fly higher than approximately 400 feet above ground level within three (3) miles of an airport without notifying the airport operator.
  - (d) Not interfere with operations and traffic patterns at any airport, heliport or seaplane base except where there is a mixed use agreement.
  - (e) Not exceed a takeoff weight, including fuel, of 55 pounds unless in compliance with the AMA Large Model Airplane program. (AMA Document 520-A.)
  - (f) Ensure the aircraft is identified with the name and address or AMA number of the owner on the inside or affixed to the outside of the model aircraft. (This does not apply to model aircraft flown indoors.)
  - (g) Not operate aircraft with metal-blade propellers or with gaseous boosts except for helicopters operated under the provisions of AMA Document #555.
  - (h) Not operate model aircraft while under the influence of alcohol or while using any drug that could adversely affect the pilot's ability to safely control the model.
  - (i) Not operate model aircraft carrying pyrotechnic devices that explode or burn, or any device which propels a projectile or drops any object that creates hazard to persons or property.

### Exceptions:

- Free Flight fuses or devices that burn producing smoke and are securely attached to the model aircraft during flight.
  - Rocket motors (using solid propellant) up to a G-series size may be used provided they remain attached to the model during flight. Model rockets may be flown in accordance with the National Model Rocketry Safety Code but may not be launched from model aircraft.
  - Officially designated AMA Air Show Teams (AST) are authorized to use devices and practices as defined within the Team AMA Program Document. (AMA Document #718.)
  - (j) Not operate a turbine-powered aircraft, unless in compliance with the AMA turbine regulations. (AMA Document #510-A.)
3. Model aircraft will not be flown in AMA sanctioned events, air shows or model demonstrations unless:
    - (a) The aircraft, control system and pilot skills have successfully demonstrated all maneuvers intended or anticipated prior to the specific event.
    - (b) An inexperienced pilot is assisted by an experienced pilot.
  4. When and where required by rule, helmets must be properly worn and fastened. They must be OSHA, DOT, ANSI, SNELL or NOCSAE approved or comply with comparable standards.

### B. RADIO CONTROL (RC)

1. All pilots shall avoid flying directly over unprotected people, vessels, vehicles or structures and shall avoid endangerment of life and property of others.
2. A successful radio equipment ground-range check in accordance with manufacturer's recommendations will be completed before the first flight of a new or repaired model aircraft.
3. At all flying sites a safety line(s) must be established in front of which all flying takes place. (AMA Document #706.)
  - (a) Only personnel associated with flying the model aircraft are allowed at or in front of the safety line.
  - (b) At air shows or demonstrations, a straight safety line must be established.
  - (c) An area away from the safety line must be maintained for spectators.
  - (d) Intentional flying behind the safety line is prohibited.

4. RC model aircraft must use the radio-control frequencies currently allowed by the Federal Communications Commission (FCC). Only individuals properly licensed by the FCC are authorized to operate equipment on Amateur Band frequencies.
5. RC model aircraft will not knowingly operate within three (3) miles of any pre-existing flying site without a frequency-management agreement. (AMA Documents #922 and #923.)
6. With the exception of events flown under official AMA Competition Regulations, excluding takeoff and landing, no powered model may be flown outdoors closer than 25 feet to any individual, except for the pilot and the pilot's helper(s) located at the flightline.
7. Under no circumstances may a pilot or other person touch an outdoor model aircraft in flight while it is still under power, except to divert it from striking an individual.
8. RC night flying requires a lighting system providing the pilot with a clear view of the model's attitude and orientation at all times. Hand-held illumination systems are inadequate for night flying operations.
9. The pilot of an RC model aircraft shall:
  - (a) Maintain control during the entire flight, maintaining visual contact without enhancement other than by corrective lenses prescribed for the pilot.
  - (b) Fly using the assistance of a camera or First-Person View (FPV) only in accordance with the procedures outlined in AMA Document #550.
  - (c) Fly using the assistance of autopilot or stabilization system only in accordance with the procedures outlined in AMA Document #560.

### C. FREE FLIGHT

1. Must be at least 100 feet downwind of spectators and automobile parking when the model aircraft is launched.
2. Launch area must be clear of all individuals except mechanics, officials, and other fliers.
3. An effective device will be used to extinguish any fuse on the model aircraft after the fuse has completed its function.

### D. CONTROL LINE

1. The complete control system (including the safety thong where applicable) must have an inspection and pull test prior to flying.
2. The pull test will be in accordance with the current Competition Regulations for the applicable model aircraft category.
3. Model aircraft not fitting a specific category shall use those pull-test requirements as indicated for Control Line Precision Aerobatics.
4. The flying area must be clear of all utility wires or poles and a model aircraft will not be flown closer than 50 feet to any above-ground electric utility lines.
5. The flying area must be clear of all nonessential participants and spectators before the engine is started.

If you are not an AMA member, please consider joining. Founded in 1936 and open to anyone interested in model aviation, the AMA is the governing body for model aviation in the United States and sanctions over 2,000 competitions annually. Membership in the AMA provides liability insurance coverage, protects modelers' rights and interests, and is required to fly at most of the 2,700+ R/C sites nationwide.

Academy of Model Aeronautics  
5161 East Memorial Drive  
Muncie, IN 47302-9252  
Toll Free (800) 435-9262  
Fax (765) 741-0057

[www.modelaircraft.org](http://www.modelaircraft.org)



**FLEX**™  
**INNOVATIONS**  
**www.flexinnovations.com**



Officially Licensed Product

© 2019 Flex Innovations, Inc.

Potenza™ is a trademark or registered trademark of Flex Innovations, Inc.

DSM®, DSM2™, and DSMX™ are trademarks of Horizon Hobby, Inc.

Futaba is a registered trademark of Futaba Denshi Kogyo Kabushiki Kaisha Corporation of Japan.

Jeti, UDI, and Jeti Model are trademarks or registered trademarks of Jelen, Ing. Stanislav of Czech Republic

HoTT is a registered trademark of SJ, Inc.