

J-3 Cub 10cc

HANGAR 9®

Instruction Manual
Bedienungsanleitung
Manuel d'utilisation
Manuale di Istruzioni



ARF



HAN5005

PNP
PLUG-N-PLAY



HAN5175

Scan the QR code and select the Manuals and Support quick links from the product page for the most up-to-date manual information.

Scannen Sie den QR-Code und wählen Sie auf der Produktseite die Quicklinks Handbücher und Unterstützung, um die aktuellsten Informationen zu Handbüchern. Scannez le code QR et sélectionnez les liens rapides Manuels and Support sur la page du produit pour obtenir les informations les plus récentes sur le manuel. Scannerizzare il codice QR e selezionare i Link veloci Manuali e Supporto dalla pagina del prodotto per le informazioni manuali più aggiornate.

HORIZON
H O B B Y

NOTICE

All instructions, warranties and other collateral documents are subject to change at the sole discretion of Horizon Hobby, LLC. For up-to-date product literature, visit horizonhobby.com or www.towerhobbies.com and click on the support or resources tab for this product.

MEANING OF SPECIAL LANGUAGE

The following terms are used throughout the product literature to indicate various levels of potential harm when operating this product:

WARNING: Procedures, which if not properly followed, create the probability of property damage, collateral damage, and serious injury OR create a high probability of superficial injury.

CAUTION: Procedures, which if not properly followed, create the probability of physical property damage AND a possibility of serious injury.

NOTICE: Procedures, which if not properly followed, create a possibility of physical property damage AND a little or no possibility of injury.



WARNING: Read the ENTIRE instruction manual to become familiar with the features of the product before operating. Failure to operate the product correctly can result in damage to the product, personal property and cause serious injury.

This is a sophisticated hobby product. It must be operated with caution and common sense and requires some basic mechanical ability. Failure to operate this Product in a safe and responsible manner could result in injury or damage to the product or other property. This product is not intended for use by children without direct adult supervision. Do not attempt disassembly, use with incompatible components or augment product in any way without the approval of Horizon Hobby, LLC. This manual contains instructions for safety, operation and maintenance. It is essential to read and follow all the instructions and warnings in the manual, prior to assembly, setup or use, in order to operate correctly and avoid damage or serious injury.

Age Recommendation: Not For Children Under 14 Years. This Is Not A Toy.

SAFETY WARNINGS AND PRECAUTIONS

Read and follow all instructions and safety precautions before use. Improper use can result in fire, serious injury and damage to property.

Components

Use only with compatible components. Should any compatibility questions exist, please refer to the product instructions, component instructions or contact the appropriate Horizon Hobby office.

Flight

Fly only in open areas to ensure safety. It is recommended flying be done at radio control flying fields. Consult local ordinances before choosing a flying location.

Propeller

Always keep loose items that can become entangled in the propeller away from the prop. This includes loose clothing or other objects such as pencils and screwdrivers. Keep your hands away from the propeller as injury can occur.

Batteries

Always follow the manufacturer's instructions when using and disposing of any batteries. Mishandling of Li-Po batteries can result in fire causing serious injury and damage.

Small Parts

This kit includes small parts and should not be left unattended near children as choking and serious injury could result.

SAFE OPERATING RECOMMENDATIONS

- Inspect your model before every flight to ensure it is airworthy.
- Be aware of any other radio frequency user who may present an interference problem.
- Always be courteous and respectful of other users in your selected flight area.
- Choose an area clear of obstacles and large enough to safely accommodate your flying activity.
- Make sure this area is clear of friends and spectators prior to launching your aircraft.
- Be aware of other activities in the vicinity of your flight path that could cause potential conflict.
- Carefully plan your flight path prior to launch.
- Abide by any and all established AMA National Model Aircraft Safety Code.

BEFORE STARTING ASSEMBLY

- Remove parts from bag.
- Inspect fuselage, wing panels, rudder and stabilizer for damage.
- If you find damaged or missing parts, contact your place of purchase.
- Charge transmitter and receiver batteries.
- Center trims and sticks on your transmitter.
- For a computer radio, create a model memory for this particular model.
- Bind your transmitter and receiver, using your radio system's instructions.

NOTICE: Rebind the radio system once all control throws are set. This will keep the servos from moving to their endpoints until the transmitter and receiver connect. It will also guarantee the servo reversal settings are saved in the radio system.

IMPORTANT FEDERAL AVIATION ADMINISTRATION (FAA) INFORMATION



Use the QR code to learn more about the Recreational UAS Safety Test (TRUST), as was introduced by the 2018 FAA Reauthorization Bill. This free test is required by the FAA for all recreational flyers in the United States. The completed certificate must be presented upon request by any FAA or law enforcement official.



If your model aircraft weighs more than .55lbs or 250 grams, you are required by the FAA to register as a recreational flyer and apply your registration number to the outside of your aircraft. Use the QR code to learn more about registering with the FAA.



According to FAA regulation, all unmanned aircraft over .55lbs (250 grams), flying in United States airspace are required to either fly within an FAA-Recognized Identification Area (FRIA) or continually transmit an FAA-registered remote identification from a Remote ID broadcast module, such as the Spektrum™ Sky™ Remote ID module (SPMA9500). Use the QR code to learn more about the FAA Remote ID regulations.

TABLE OF CONTENTS

Notice.....	2
Meaning of Special Language.....	2
Safety Warnings and Precautions.....	2
Safe Operating Recommendations.....	2
Before Starting Assembly.....	2
Important Federal Aviation Administration (FAA) Information.....	2
Replacement Parts.....	3
Required for Completion, Glow Engine Installation (ARF).....	4
Required for Completion, Gas Engine Installation (ARF).....	4
Required for Completion, Electric Motor Installation (ARF).....	4
Required for Completion (PNP).....	4
Tools Required.....	4
Required Adhesives.....	4
Optional Items.....	4
Removing Wrinkles.....	5
Building Precautions.....	5
Transportation and Storage.....	5
Replacement Covering.....	5
Checking Blind Nuts.....	5
Using this Manual.....	5
Aileron Hinging.....	5
Aileron Servo Installation.....	6
Wing Strut Installation.....	10
Wing Installation.....	10
Elevator Installation.....	11
Rudder Installation.....	14
Tail Rigging.....	15
Landing Gear Installation.....	16
Rudder and Elevator Servo Installation.....	17
Windshield Preparation.....	19
Electric Motor Installation.....	19
Engine Installation.....	20
Cowling Installation.....	22
Window Installation.....	23
Empennage Installation.....	23
Wing Installation.....	24
Landing Gear Installation.....	26
Battery and Receiver Installation.....	27
Float Installation.....	27
Center of Gravity.....	28
Control Throws.....	29
Preflight Checklist.....	29
Daily Flight Checks.....	29
Limited Warranty.....	29
Warranty and Service Contact Information.....	30
WEEE NOTICE.....	30
Academy of Model Aeronautics National Model Aircraft Safety Code.....	31
Building and Flying Notes.....	31

REPLACEMENT PARTS

Item #	Description
HAN500501	Fuselage; ARF: J-3 Cub 10cc
HAN500502	Wing; LH: J-3 Cub 10cc
HAN500503	Wing; RH: J-3 Cub 10cc
HAN500504	Stabilizer with Elevators; ARF: J-3 Cub 10cc
HAN500505	Rudder; ARF: J-3 Cub 10cc
HAN500506	Cowling with Dummy Engine: J-3 Cub 10cc
HAN500507	Windshield Hatch: J-3 Cub 10cc
HAN500508	Top Hatch: J-3 Cub 10cc
HAN500509	Hardware Set: J-3 Cub 10cc
HAN500510	Engine Mount: J-3 Cub 10cc
HAN500511	Wing Strut Set: J-3 Cub 10cc
HAN500512	Pushrod Set: J-3 Cub 10cc
HAN500513	Windshield and Window Set: J-3 Cub 10cc
HAN500514	EP Mount Box: J-3 Cub 10cc
HAN500515	Tailwheel Assembly: J-3 Cub 10cc
HAN500516	Wheel Set: J-3 Cub 10cc
HAN500517	Fuel Tank: J-3 Cub 10cc
HAN500518	Landing Gear: J-3 Cub 10cc
HAN500519	Wheel Pants Set: J-3 Cub 10cc
HAN500520	Wing Tube: J-3 Cub 10cc
HAN500521	Tail Bracing Wire Set: J-3 Cub 10cc
HAN500522	Decal Sheet: J-3 Cub 10cc
HAN500523	Fuel Cap: J-3 Cub 10cc
HAN500524	Spinner Nut; 5/16-24 Thread: J-3 Cub 10cc
HAN500525	Spinner Nut; 1/4-28 Thread: J-3 Cub 10cc
HAN500526	Spinner Nut; M7x1mm Thread: J-3 Cub 10cc
HAN500527	Dummy Engine Parts: J-3 Cub 10cc
HAN500528	Cockpit Parts: J-3 Cub 10cc
HAN500529	Pilot Bust: J-3 Cub 10cc
HAN517501	Fuselage; PNP: J-3 Cub 10cc
HAN517504	Stabilizer with Elevators; PNP: J-3 Cub 10cc
HAN517505	Fin and Rudder Assembly; PNP: J-3 Cub 10cc
EFLP1510E	15x10E Propeller: J-3 Cub 10cc
EFLP1407E	14x7E Propeller: J-3 Cub 10cc
EFLA5606	Float Strut Set: Hangar 9 J-3 Cub: J-3 Cub 10cc
SPMXAM4715	Avian 4260-480Kv Outrunner Brushless Motor, PNP
SPMXAE70A	Avian 70-Amp Smart Lite Brushless ESC, 3S-6S: IC5, PNP
SPMSA6380	A6380 HV Digital Metal Gear Aircraft Servo, PNP

REQUIRED FOR COMPLETION, GLOW ENGINE INSTALLATION (ARF)

# Required	Item #	Description
1	SAIE062B	FA-62B AAC with Muffler: BX
1	SPM-1032	AR637T+ DSMX 6-Channel AS3X+ & SAFE Telemetry Receiver
5	SPMSA6380	A6380 HV Digital Metal Gear Aircraft Servo
2	SPMA3002	Servo Extension Lead: 9" Heavy-Duty
1	DUB222	Silicone Fuel Tubing, 2', Medium
1	APC13060	Sport Propeller, 13 x 6

REQUIRED FOR COMPLETION, GAS ENGINE INSTALLATION (ARF)

# Required	Item #	Description
1	SAIEG11	FG-11 Gas Single Cylinder Engine: BZ
1	SPM-1032	AR637T+ DSMX 6-Channel AS3X+ & SAFE Telemetry Receiver
5	SPMSA6380	A6380 HV Digital Metal Gear Aircraft Servo
2	SPMA3002	Servo Extension Lead: 9" Heavy-Duty
1	SUL211	2' ProFlex Universal Fuel Line
1	APC13070	Sport Propeller, 13 x 7
1	SPM1300LPRX	7.4V 1300mAh 2S 5C Li-Po Receiver Battery; JST-RCY
1	SPM9530	Switch Harness: 3-Wire

REQUIRED FOR COMPLETION, ELECTRIC MOTOR INSTALLATION (ARF)

# Required	Item #	Description
1	SPMXAM4715	Avian 4260-480Kv Outrunner Brushless Motor
1	SPMXAE70A	Avian 70-Amp Smart Lite Brushless ESC, 3S-6S: IC5
1	SPM-1032	AR637T+ DSMX 6-Channel AS3X+ & SAFE Telemetry Receiver
4	SPMSA6380	A6380 HV Digital Metal Gear Aircraft Servo
2	SPMA3002	Servo Extension Lead: 9" Heavy-Duty
1	SPMX50004S30	14.8V 5000mAh 4S 30C Smart LiPo Battery: IC5
1	EFLP1510E	15x10E Propeller (for use with 4S LiPo)
1	SPMX32006S30	22.2V 3200mAh 6S 30C Smart G2 LiPo Battery: IC5
1	EFLP1407E	14x7E Propeller (for use with 6S LiPo)

REQUIRED FOR COMPLETION (PNP)

# Required	Item #	Description
1	SPM-1032	AR637T+ DSMX 6-Channel AS3X+ & SAFE Telemetry Receiver
1	SPMX50004S30	14.8V 5000mAh 4S 30C Smart LiPo Battery: IC5
1	SPMX326S30	22.2V 3200mAh 6S 30C Smart G2 LiPo Battery: IC5

TOOLS REQUIRED

Description	
Box or open end wrench: 10mm, 7/16-inch, 1/2-inch	Light machine oil
Clamps	Low tack tape
Covering iron	Medium grit sandpaper
Drill	Mixing cups
Drill bit set, metric and english	Mixing sticks
Epoxy brushes	Pencil
Felt-tipped pen	Phillips screwdriver #0, #1, #2
Flat blade screwdriver	Pin vise
Flat file	Pliers
Flux paste	Razor saw
Heat gun	Ruler
Hemostats	Sanding drum for rotary tool
Hex wrench set, metric and english	Scissors
Hobby knife with #11 blade	Side cutter
Hobby scissors	Silver solder
Hobby square	Stepped reamer
Hook and loop tape	Toothpicks

REQUIRED ADHESIVES

Description
15-minute epoxy
30-minute epoxy
Canopy glue
Thin CA
Medium CA
Threadlock, low strength

OPTIONAL ITEMS

# Required	Item #	Description
1	EFLA5600S	Float Set with Hardware, Silver; 39.5"
1	EFLA5606	Float Strut Set: J-3 Cub 10cc
1	EXRA055J	Charge Receptacle: JR/HRC/AIRZ

REMOVING WRINKLES

The covering of your model may develop wrinkles during shipping. Use a sealing iron (HAN1017) with a sealing iron sock (HAN1018) to remove them. Start with a lower heat setting and use caution while working around areas where the colors overlap to prevent separating the colors. It is also advised to use caution around the canopy as it is plastic and could distort with excessive heat. Avoid using too much heat, especially near seams, which could also separate the film. Placing a cool damp cloth on adjacent colors will also help prevent the separation of the colors while removing wrinkles. A heat gun (HAN100) can also be used, but with caution as it produces extreme heat and it is easy to damage the covering.

BUILDING PRECAUTIONS

Prepare the work surface prior to beginning the build. The surface should be soft and free of any sharp objects. We recommend resting the airframe parts on a soft towel or pit mat to prevent scratching or denting the surface of the aircraft.

TRANSPORTATION AND STORAGE

When transporting and storing your model, you will need a minimum of 85 in (2.2 m) in length, and 29 inches (74cm) in height to accommodate the size of the fuselage. We also recommend the use of wing and stabilizer bags to help protect these surfaces during transport and storage. The control horns and linkages can cause damage to other surfaces even when placed in storage bags. Always transport and store the wings and stabilizer so the linkages do not contact other panels to prevent damage.

REPLACEMENT COVERING

Your model is covered with UltraCote® film in the following colors. If repairs are required, order these coverings to make those repairs.

HANU884 Cub Yellow (Oracover 30)

HANU874 Black (Oracover 71)

CHECKING BLIND NUTS

When building the aircraft, you will be required to thread machine screws into blind nuts. We recommend pre-threading the screws to make sure the blind nuts are clear of any debris. If the screws do not thread in easily, clear the threads using the appropriate tap and tap handle.

USING THIS MANUAL

This manual covers the assembly of both the ARF and PNP versions of this aircraft. Please read through the manual to identify which sections pertain to your particular model.

The section on Page 5 starting with "Aileron Hinging" covers the ARF build. The section on Page 23 starting with "Empennage Installation" covers the PNP build. The section starting on Page 26 starting with "Battery and Receiver Installation" covers items for both the ARF and PNP versions of the model.

AILERON HINGING

1. Use a felt-tipped pen to mark the center of the slot in the hinges on both the wing and control surface.

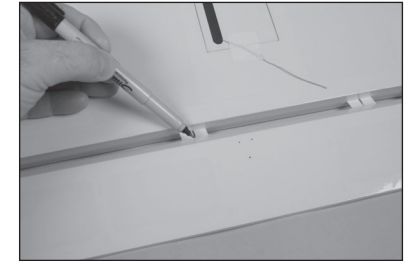

2. Separate the aileron from the wing. Set the hinges aside. Use a pin vise or rotary tool and 1/16-inch (1.5mm) drill bit to drill the center location in the trailing edge and control surface previously marked.

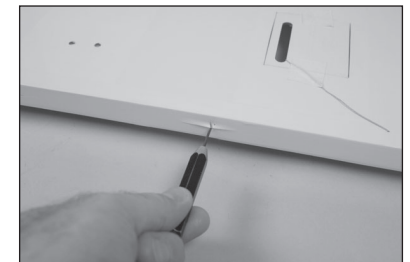
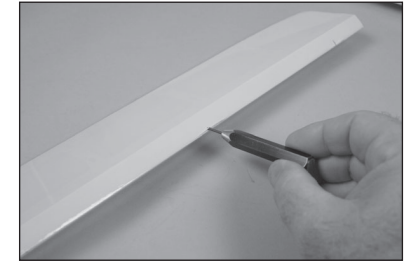

3. Place a T-pin in the center of each hinge. This will keep the hinges centered when they are installed.

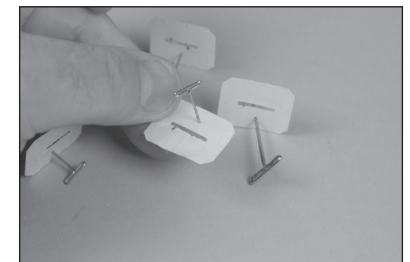

4. Fit the hinge in the hinge slot. Align the slot in the hinge with the hole in the wing.

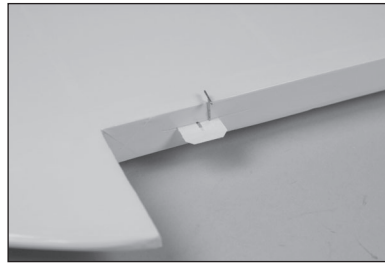

5. Fit the aileron into position on the hinges. Remove the T-pins from the hinges.

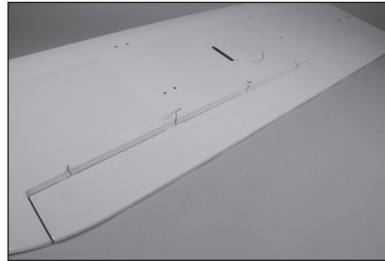

6. Check the gap between the wing and aileron at both ends. Adjust so the gap is identical.

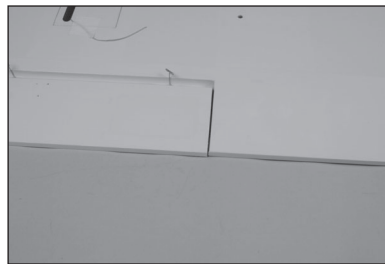
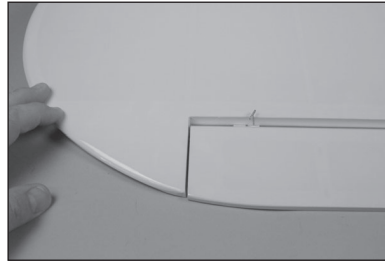

7. Apply several drops of thin CA to each of the hinges, both on the top and bottom of the hinge.



- Do not use accelerator. The CA must be allowed to wick into the hinge to provide the best bond between the hinge and surrounding wood.
- Check the opposite side of the surfaces to ensure that excess CA hasn't run. If this has occurred, use CA debonder or acetone to remove it before it cures completely. Keeping the wing horizontal will help avoid this.

8. Once the CA has fully cured, gently pull on the wing and aileron to make sure the hinges are secure.

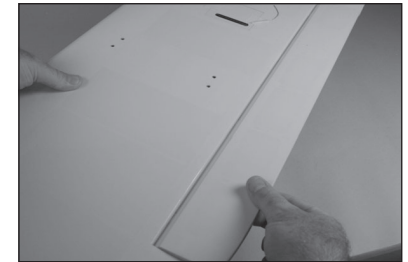

- Reapply CA to any hinges that are not glued securely.

9. Break in the hinges by flexing the control surface through its range of motion in both directions.

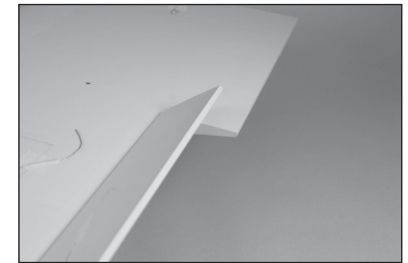

- Repeat this section to install the remaining aileron.

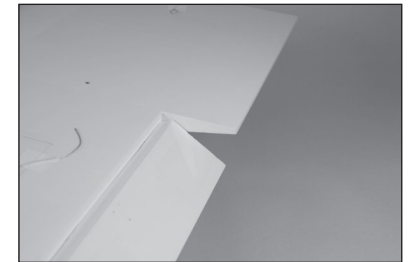

AILERON SERVO INSTALLATION

10. Thread an M2 x 10mm self-tapping screw into each of the three holes for securing the aileron control horn to the aileron. Remove the screws before proceeding.



11. Apply 1–2 drops of thin CA in each hole to harden the surrounding wood. Allow the CA to fully cure before proceeding.

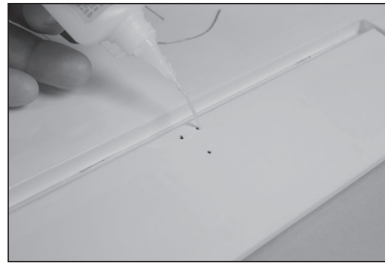

12. Secure the control horn to the aileron using three M2 x 10mm self-tapping screws and a #1 Phillips screwdriver.



13. Remove the aileron servo hatch from the wing.

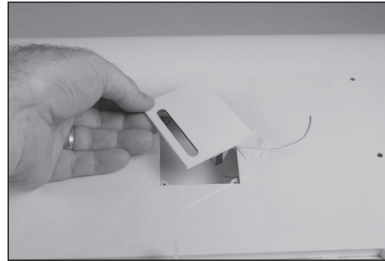

14. Install the rubber grommets and eyelets in the servo mounting tabs following the instructions provided with the servo.

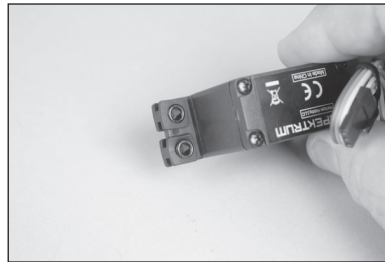

15. Use a pin vise or drill and 5/64-inch (2mm) drill bit to drill through the holes in the servo mount.

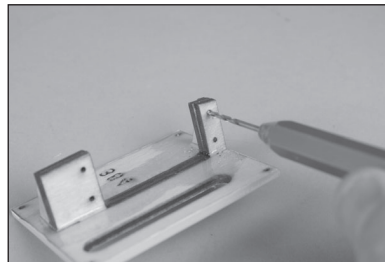

16. Thread a servo mounting screw into each hole, then remove all the screws.

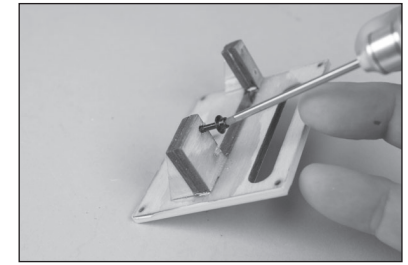

17. Apply 1–2 drops of thin CA in each hole to harden the surrounding wood. Allow the CA to fully cure before proceeding.

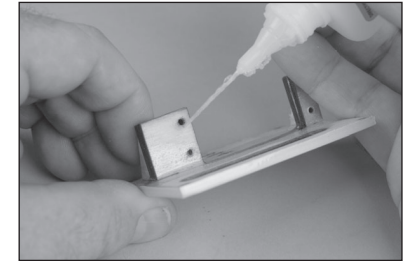

18. Position the servo with the servo output shaft centered in the opening for the servo arm.

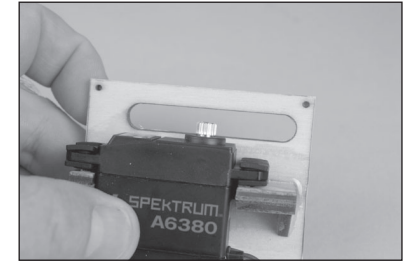

19. Mount the servo using the screws provided with the servo. Note the orientation of the servo on the servo cover.

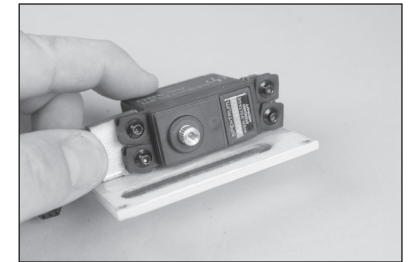

20. Center the servo using a screwdriver or the radio system. Place the control horn on the servo so it is perpendicular to the servo. Remove any arms from the servo horn that will interfere with the operation of the servo.

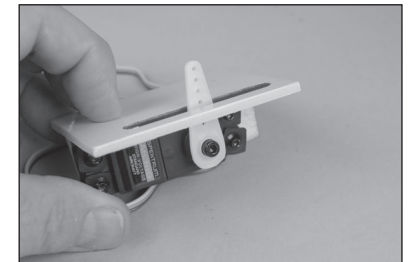

21. When attaching the linkage to the servo arm, use the hole that is 5/8 inch (16mm) from the center of the servo horn. This hole will need to be enlarged using a pin vise and 5/64-inch (2mm) drill bit.

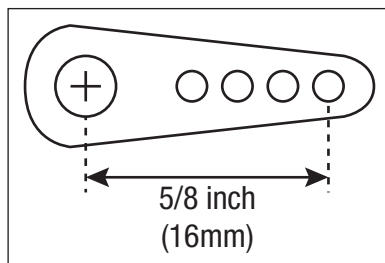

22. Secure a 9-inch (225mm) servo extension to the servo lead using a commercially available retainer (Servo Connector Clips, SPMA3054).

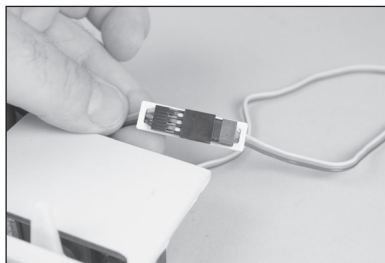

23. Use a toothpick or hobby knife with a #11 blade to puncture the servo cover for the mounting screws.

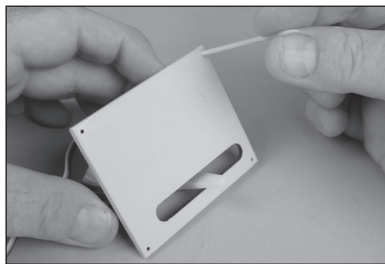

24. Thread an M2 x 10mm self-tapping screw into each of the holes for securing the aileron servo cover to the wing. Remove the screws before proceeding. Apply 1–2 drops of thin CA in each hole to harden the surrounding wood. Allow the CA to fully cure before proceeding.



25. Tie or tape the string located inside the wing to the end of the servo lead.

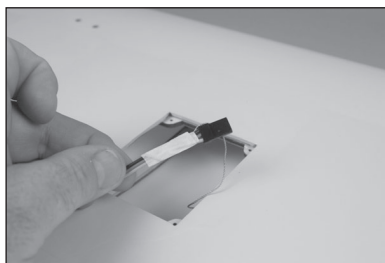

26. Guide the servo lead for the aileron through the wing to the wing root.



27. Place an M2 washer on each of the four M2 x 10mm self-tapping screws that will be used to secure the aileron servo cover.



28. Secure the aileron servo cover using a #1 Phillips screwdriver and four M2 x 10mm self-tapping screws.

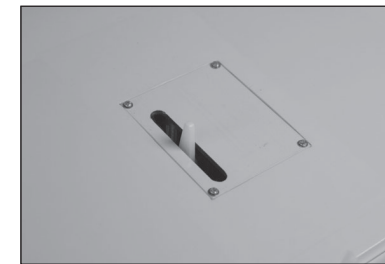

29. Apply a small piece of low-tack tape to the aileron to keep it centered when preparing the aileron linkage.

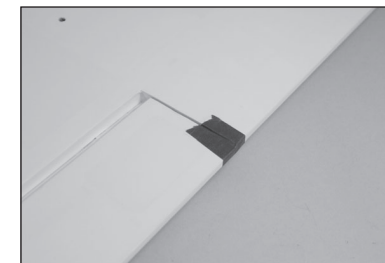

30. Locate the 7 1/8 inch (181mm) aileron linkage. Thread the clevis on threaded rod until the end of the threaded rod is visible between the forks of the clevis.

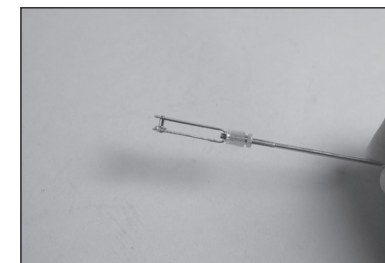

31. Attach the clevis to the outer hole of the aileron control horn.

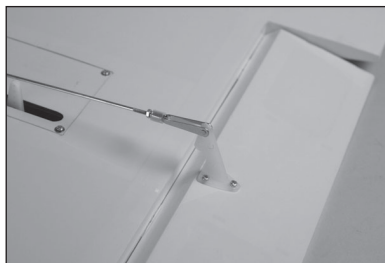

32. Use a felt-tipped pen to mark the linkage where it crossed the hole in the servo arm prepared earlier in this section.



33. Remove the linkage and make a 90-degree bend in the wire at the mark made in the previous step.

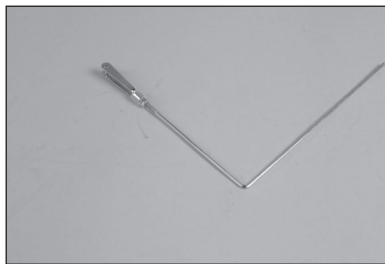

34. Trim the wire 1/4-inch (6mm) above the bend in the wire. Use a flat file to remove any sharp edges that remain from cutting the wire.



35. Remove the tape holding the aileron in position. Attach the clevis to the control horn. Insert the wire into the hole in the aileron servo arm.



36. Check the alignment between the wing and aileron. Adjust the clevis if necessary so they are aligned.

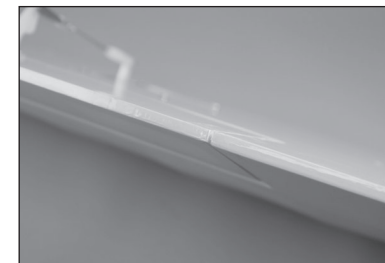

37. Slide the nylon retainer on the wire.

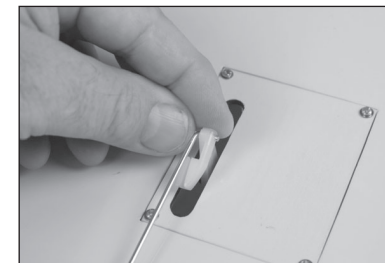

38. Use pliers to snap the retainer on the wire, securing the wire to the servo arm.

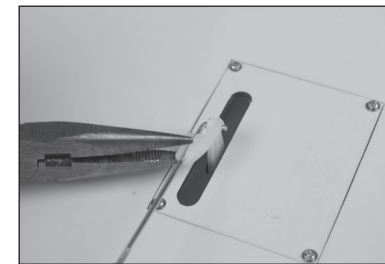

39. Slide the silicone retainer over the forks of the clevis.



40. Tighten the nut against the clevis to prevent it from vibrating loose, then apply a very small amount of medium-strength threadlock.



➔ Repeat this section for the remaining aileron servo.

WING STRUT INSTALLATION

41. Attach the strut fitting near the aileron to the bottom of the wing using four M3 x 12 socket head cap screws and four M3 lock washers. Apply a drop of threadlock on each screw before tightening them using a 2.5mm hex wrench.

→ Do not tighten the screws so much that the wing sheeting is compressed.



42. Thread the strut ends on the wing struts. There are two front struts (slightly shorter) and two rear struts (longer) for each wing panel.

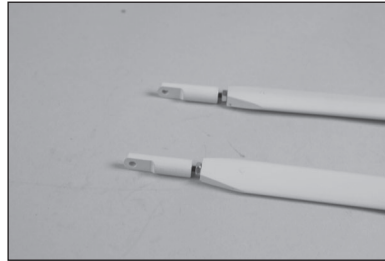
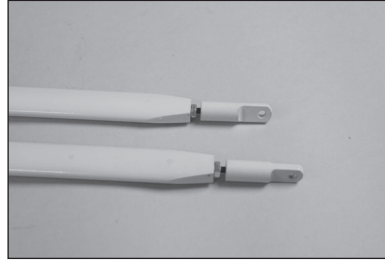

43. Attach the struts to the brackets using an M3 x 15mm socket head cap screw and M3 lock nut.

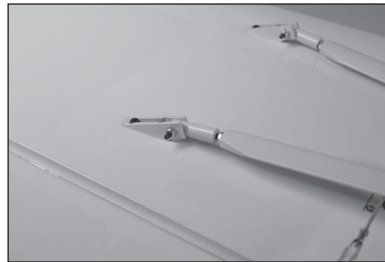

44. Check the position on the holes in the struts in comparison to the jury strut holes in the wing. The holes in the strut will be close to the holes in the wing when installed correctly.

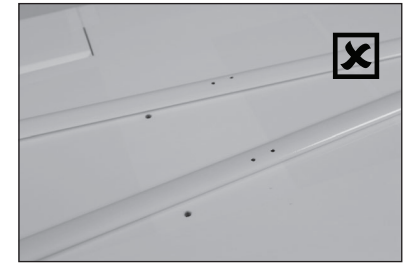
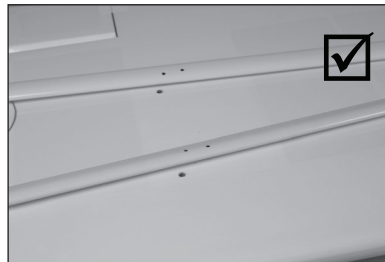

45. Attach the jury strut to the main struts using two nylon straps and four M3 x 10 socket head cap screws. Tighten the screws using a 2.5mm hex wrench.

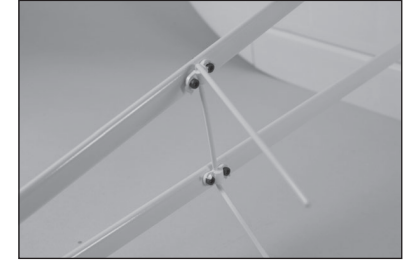

46. Thread an M3 lock nut on each of the screws to secure their position. Tighten the nuts using an M5.5 nut driver.

→ Repeat this section to install the remaining strut assembly.

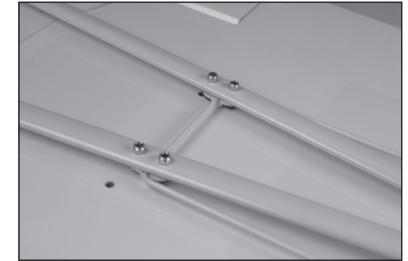

WING INSTALLATION

47. Attach the strut mounting tabs to the fuselage using four M3 x 10mm button head screws and a 1.5mm hex wrench.



48. Slide the wing tube into the wing tube socket.



49. Remove the windshield hatch from the fuselage. It is secured quite firmly with four magnet retainers. You may find it easier to grip each side of the windshield towards the top, and pull forward. Another good method is to separate the top of the hatch with a thin plastic wedge.

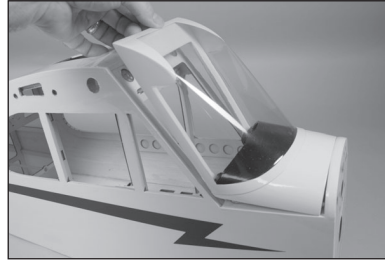

→ Avoid picking at the top edge, as it may be possible to separate the windshield from the frame.

50. The top hatch has an internal spring-loaded latch. Release the hatch by pulling the latch forward, then pushing upwards.

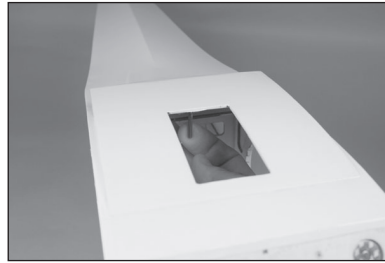

51. Slide the wing tube in the socket in the fuselage.



52. Slide the wing panel tight against the fuselage, guiding the aileron lead into the fuselage. Secure the wing panel using the 1/4-20 nylon wing bolt.



53. The jury strut ends will fit into the holes in the underside of the wing.

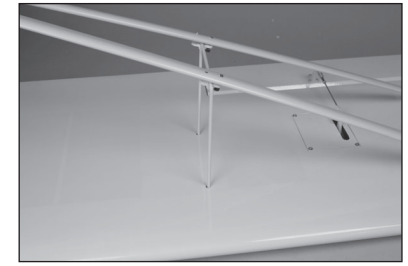

54. Adjust the strut end so the hole in the strut end aligns with the hole in the mounting tab. The strut ends fit above the tab. Insert the pin from the fuselage side and slide the retaining clip through the hole in the pin.

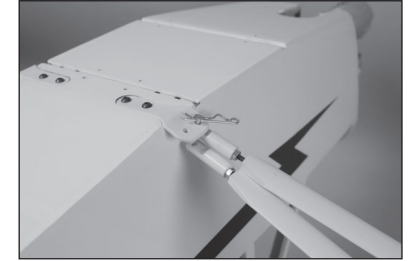

→ When the fuselage is supported inverted, the weight of the wings will naturally set the correct dihedral. Adjust the strut ends in this position. When/if assembling the model upright, this will cause the strut ends to not quite align, which is normal. Use slight pressure to align the holes, then insert the pins.

55. Repeat the above process for the remaining strut.

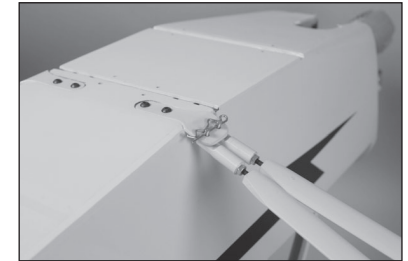

56. With the strut attached, use needle nose pliers to tighten the nuts against the strut end fittings to keep them from vibrating loose.

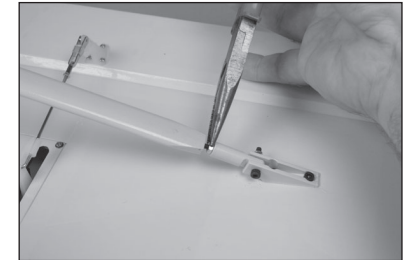

→ Use threadlock on all metal-to-metal fasteners.

→ Install the remaining wing panel before proceeding.

ELEVATOR INSTALLATION

57. Separate the elevators from the stabilizer. Set the hinges, joiner wire and elevators aside.

→ Make sure to prepare the hinge slots in the elevators and stabilizer as outing in the aileron installation section.

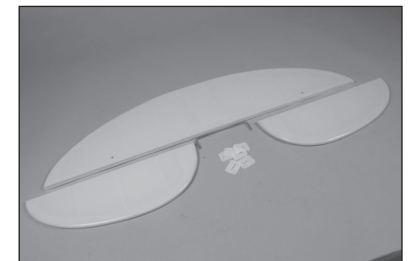

58. Place the stabilizer on the fuselage. Center the stabilizer on the fuselage.

→ The elevator can be left in position to aid in centering the stabilizer.

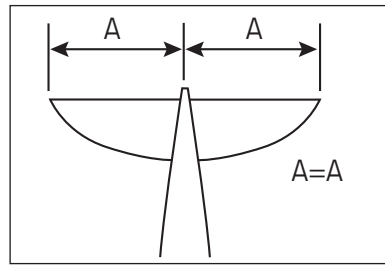

59. Stand back 8-10 feet (2-3 meters) and check that the stabilizer is aligned with the wing. Lightly sand the stabilizer saddle on the fuselage, if necessary, to correct any misalignment.

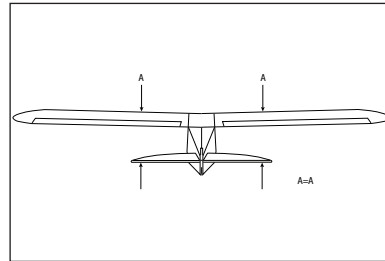

60. Measure from each wing tip to each stabilizer tip. Adjust the stabilizer so the measurements are the same for both sides.

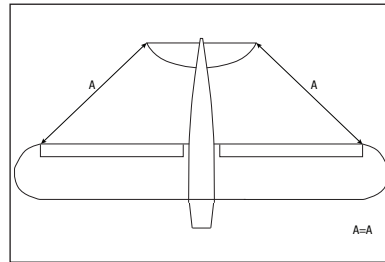

61. Use a felt-tipped pen to transfer the fuselage outline onto the top and bottom of the stabilizer.

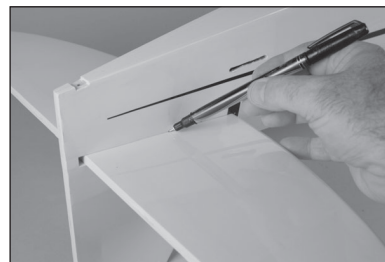

62. Use a ruler and carefully cut the covering 1/8 inch (3 mm) inside the line drawn on the stabilizer to remove the covering from the center of the stabilizer. Remove the top and bottom covering. Use care not to cut into the underlying wood, which may weaken the stabilizer. Remove any lines from the stabilizer using a paper towel and isopropyl alcohol.

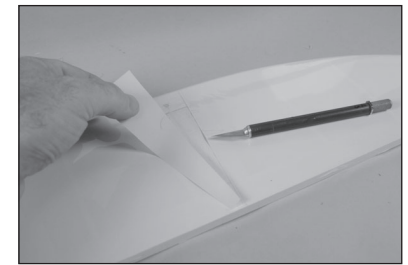

63. Mix 20g of 30-minute epoxy. Use an epoxy brush to apply epoxy to the exposed wood on the top and bottom of the stabilizer.

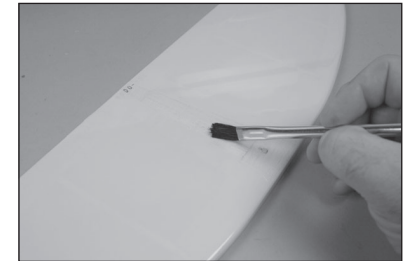

64. Slide the stabilizer into position. Remove any epoxy from the fuselage and stabilizer using a paper towel and isopropyl alcohol. There will be excess epoxy, so use a few paper towels to properly remove it from the outside of the model.

→ Check the alignment as the epoxy cures.



65. Use medium grit sandpaper to roughen the joiner wire where it will contact the elevators.

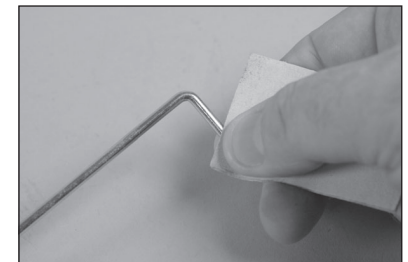

66. Use isopropyl alcohol and a paper towel to remove any oils or debris from the joiner wire.



67. Use a toothpick or hobby knife to puncture the covering so the control horn mounting screws can be installed.



68. Use a hobby knife with a #11 blade to separate the control horn back plate from the control horn.



69. Insert three M2 x 15mm machine screws through the back plate, then into the holes in the elevator. Note the positioning of the back plate in relationship to the elevator.



70. Slide the control horn on the screws, then secure the control horn using three M2 nuts. Tighten the nuts, avoiding crushing the underlying structure.

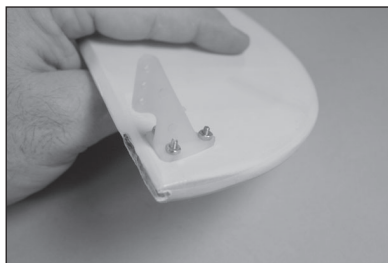

71. Apply a drop of thin CA to a toothpick. Use the toothpick to apply the CA to the exposed threads of the screws.

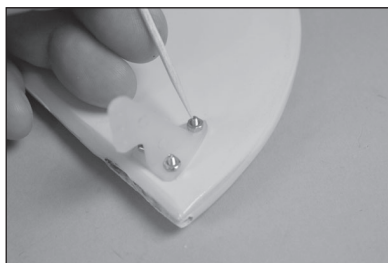

72. Place a T-pin in the center of each hinge. This will keep the hinges centered when they are installed. Insert the hinges in the elevator



73. Tape a piece of clear packaging or waxed paper to the area where the joiner will fit to avoid gluing it to the stabilizer during its installation.

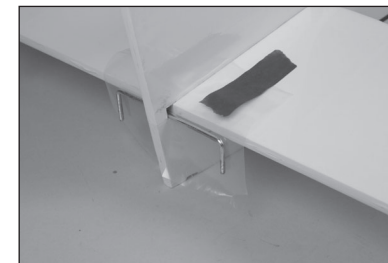

- Make sure to read through and test fit the elevators in the following steps before mixing any epoxy.

74. Slide the joiner wire into position. Apply a small amount of 30-minute epoxy to the joiner wire where it will contact the elevators.

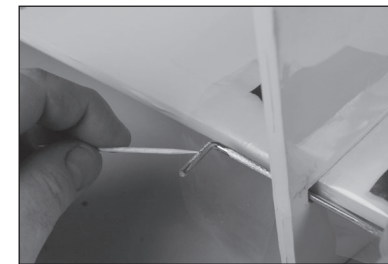

75. Apply epoxy to the area of the elevators where the joiner wire will fit.

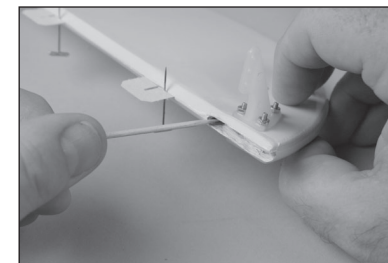

76. Fit the elevators in position with the hinges. The joiner wire will fit fully into the elevators. Allow the epoxy fully cure before proceeding.

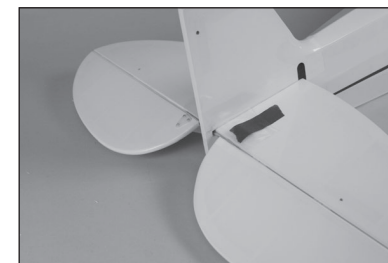

77. Remove the clear packaging (or waxed paper). Use a hobby knife to remove any excess epoxy if necessary.

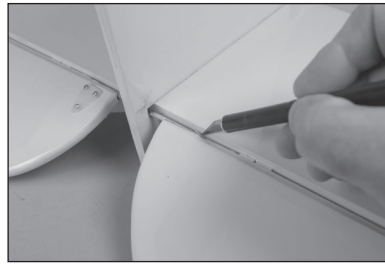

78. Apply several drops of thin CA to each of the hinges, both on the top and bottom of the hinge.

- ➔ Do not use accelerator. The CA must be allowed to wick into the hinge to provide the best bond between the hinge and surrounding wood.
- ➔ Check the opposite side of the surfaces to ensure that excess CA hasn't run. If this has occurred, use CA debonder or acetone to remove it before it cures completely.



79. Remove the wing panels from the fuselage. Place the foam tubing on the jury struts to prevent damage to the wing during transport or storage.

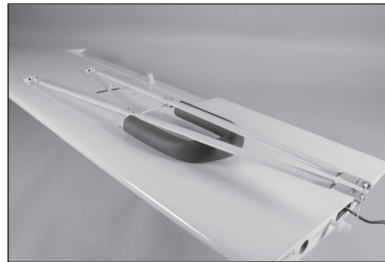
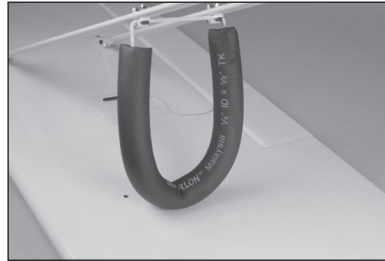

RUDDER INSTALLATION

80. Loosen the setscrew in the wheel collar using a 1.5mm hex wrench. Slide the tail wheel bracket (small hole) onto the tail gear wire.

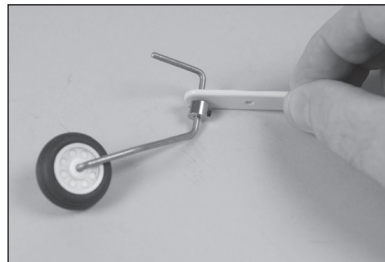

81. Use the technique outlined for the elevator joiner wire to prepare and glue the tail gear wire into position using 5-minute epoxy.

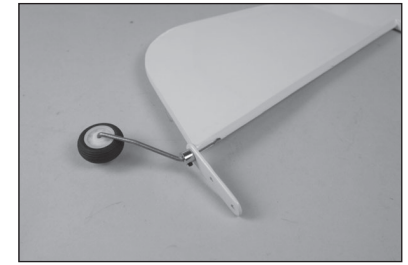

82. Install the rudder control horn using three M2 x 15mm machine screws and three M2 nuts. Use the instructions from the elevator control horn installation as a guide.

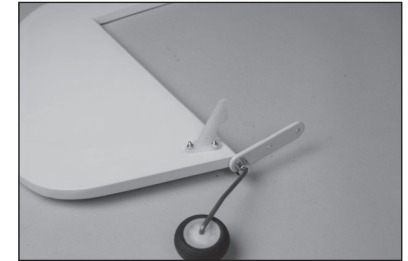

83. Hinge the rudder to the fin using three hinges. The hinging process has been outlined earlier in this manual. Make sure there is enough clearance between the fin and rudder at the top of the fin so it can move without interference.

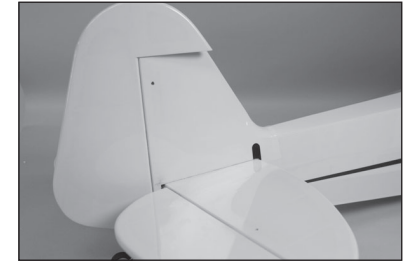

84. Secure the tail wheel bracket using two M3 x 10 sheet metal screws. The rigging wire bracket will fit between the fuselage and tail wheel bracket as shown.



85. Slide the wheel collar against the tail wheel bracket and tighten the setscrew.



TAIL RIGGING

86. Bend each of the aluminum cable tabs slightly using pliers.

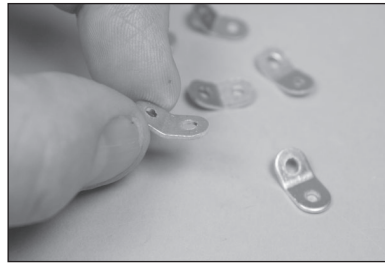

87. Slide an M3 x 14mm machine screw through the pre-bent aluminum cable tab. Slide the screw through the hole in the top side of the stabilizer.



88. Slide a second tab on the screw from the bottom of the stabilizer. Secure the tabs using an M3 nut. Use threadlock on all metal-to-metal fasteners.



→ Install tabs on the left and right of the stabilizer, and near the top of the fin.

→ Do not overtighten the hardware and compress the wood structure of the stabilizer or fin.

89. Thread a clevis on the cable fitting so the threaded end is barely visible between the forks of the clevis. Prepare all four of the cable fitting end.

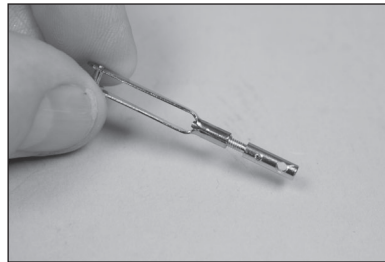

90. Slide the sleeve on the end of the cable.

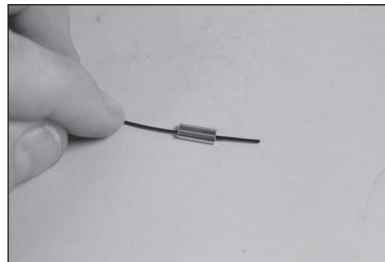

91. Slide the cable through the hole in the fitting

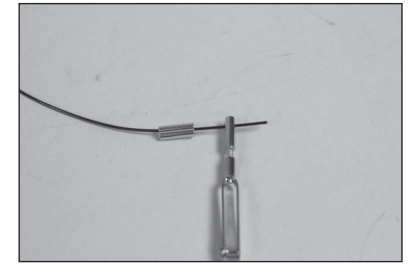

92. Pass the cable back through the sleeve. Use crimping pliers to secure the sleeve to the cable. Prepare four of the cables at this time so each has a fitting on one end of the cable.

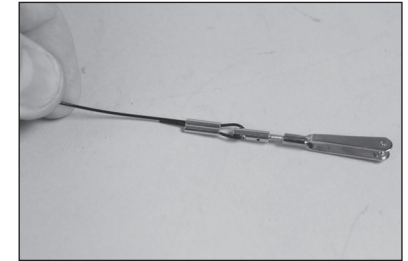

93. Attach the clevis to the tabs located on the elevator.

→ When installing the cable ends, make sure the cable does not loop over and get stuck on the fitting.

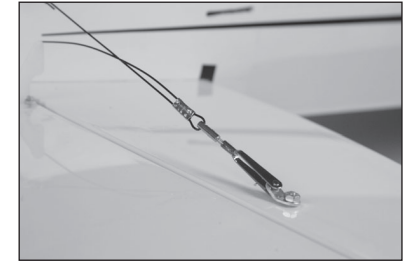

94. Slide the sleeve on the end of the cable. Slide the cable through the hole in the bracket. Pass the cable back through the sleeve. Apply light tension on the cable and use crimping pliers to secure the sleeve to the cable.



95. Use side cutters to trim any excess wire that may interfere with the operation of your model.



96. Install the remaining rigging to complete the tail installation.



LANDING GEAR INSTALLATION

→ Skip to Step 103 if wheel pants are not going to be installed.

97. Install the wheel pant bracket using two M3 x 10mm button head screws. Tighten the screws using a 2mm hex wrench.

→ Use a drop of threadlock on all metal-to-metal fasteners.



98. Use a file to make two 1/2-inch (13mm) wide flat areas on the bottom of the axle. The first area is near the gear, and the second is near the end of the axle.

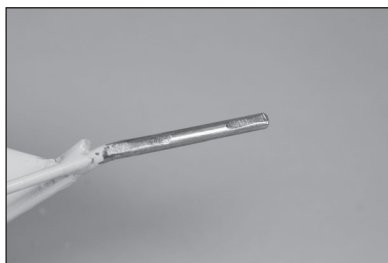

99. Slide the wheel pant, then a wheel collar, onto the axle.



100. Slide the wheel on the axle. The assembly can then be slid fully onto the axle.

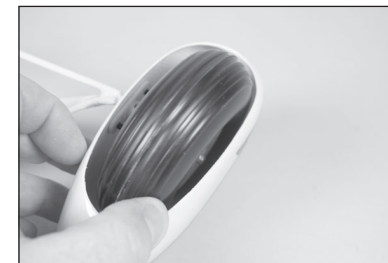

101. Secure the wheel using a wheel collar and setscrew on the outside edge of the wheel. Make sure the wheel can rotate freely on the axle.

→ Use a very small drop of threadlock on the wheel collar setscrews. An excessive amount can make them difficult to remove.

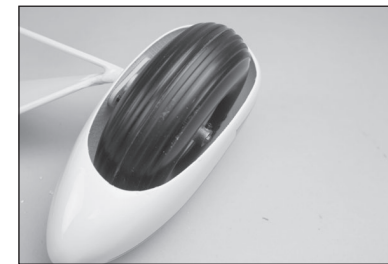

102. Tighten the setscrew in the wheel pant bracket to secure the wheel pant to the axle. The wheel pant center line will be parallel to the top edge of the landing gear.

→ It may be necessary to alter the flat area slightly to achieve the correct alignment of the wheel pant.

→ Use a drop of threadlock on all metal-to-metal fasteners.

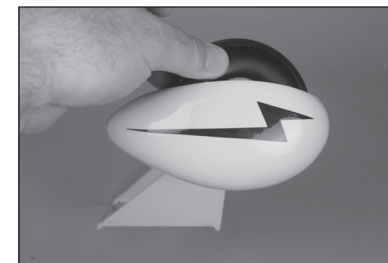

103. Use a file to make two 1/2-inch (13mm) wide flat areas on the bottom of the axle. The first area is near the gear, and the second is near the end of the axle.

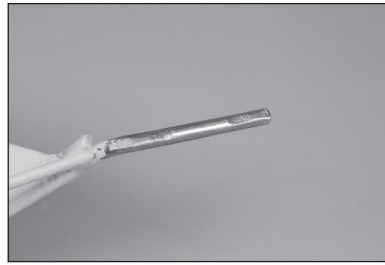

104. Slide a wheel collar on the axle.

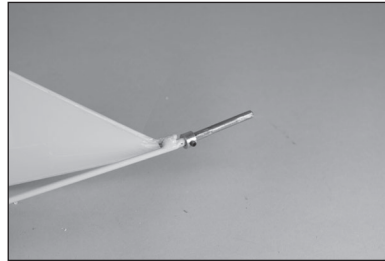

105. Inspect the wheel. One side has three holes to attach the hub cap to the wheel. These holes need to face outboard.



106. Slide the wheel on the axle.

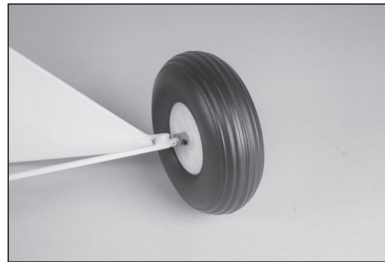

107. Slide a wheel collar on the axle. Tighten the setscrew so the wheel collar is flush with the end of the axle.

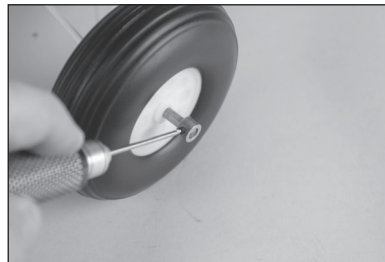

108. Slide the inside wheel collar against the wheel and tighten the setscrew. Make sure the wheel can rotate freely.

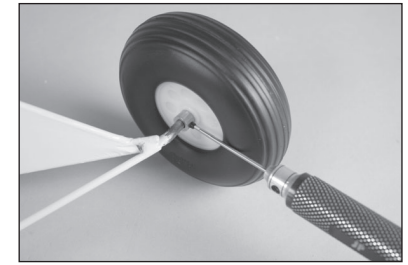

109. Attach the hub cap using three M2 x 6mm countersunk screws. Use a #1 Phillips screwdriver to tighten the screws.



110. DuBro J-3 wheels can be installed as an option. Make sure to follow the instructions included with the wheels.

➔ The axle will need to be shimmed. This can be done with a wrap of aluminum tape, in the forward-rotation direction. Another option is thin-wall tubing. The axle will also require trimming to length, approximately 37mm, to allow installation of the hubcap.

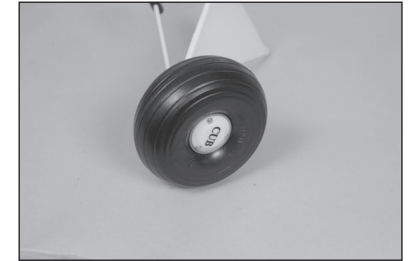

111. Attach the landing gear to the fuselage using two flat landing gear straps at the rear and two saddle straps at the front. Secure the straps using eight M3 x 10 sheet metal screws.



RUDDER AND ELEVATOR SERVO INSTALLATION

112. Mount the rudder and elevator servos in the fuselage. Follow the same procedure as mounting the aileron servos. The output shaft of the servos will face toward the front of the fuselage.



- 113.** Center the servos using the radio system. Place the servo arm on the servos so they are 90-degrees to the servo center line. Remove any arms that may interfere with the operation of the linkages.



- 114.** Remove the clevis and nut from the long pushrod. Insert the pushrod into the tube from inside the fuselage.

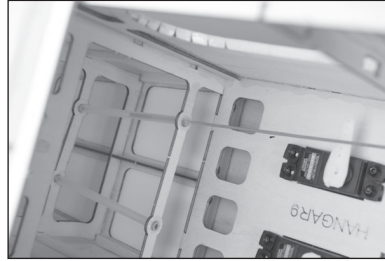

- 115.** Attach the clevis to the rudder control horn.

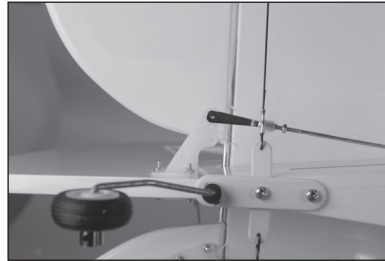

- 116.** Use tape or clamps to hold the rudder in alignment with the fin.



- 117.** When attaching the linkage to the rudder and elevator servo arms, use the hole that is 13/16 inch in (21mm) from the center of the servo horn. This hole will need to be enlarged using a pin vise and 5/64-inch (2mm) drill bit.

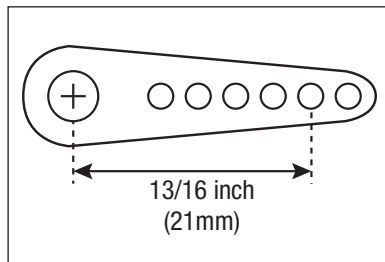

- 118.** Use a felt-tipped pen to mark the pushrod wire where it crosses the servo arm.



- 119.** Remove the clevis from the pushrod wire. Prepare the wire by bending it and securing it to the control horn as outline with the aileron servo installation.

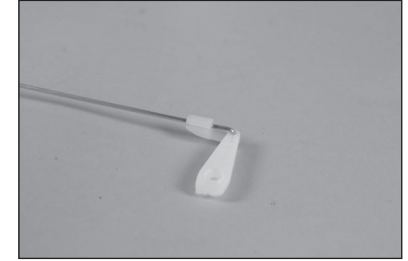

- 120.** Slide the pushrod wire back into the pushrod tube. Reinstall the servo arm and secure it using the hardware included with the servo.

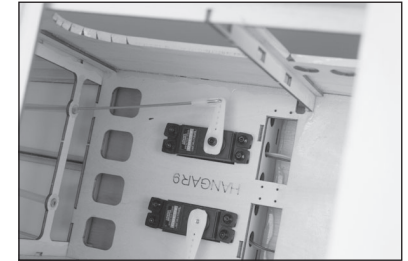

- 121.** Thread the nut and clevis back on the pushrod. Attach the clevis to the control horn. With the radio system on, check that the rudder is centered. If not, adjust the clevis as necessary. Once adjusted, tighten the nut against the clevis to prevent it from vibrating loose.

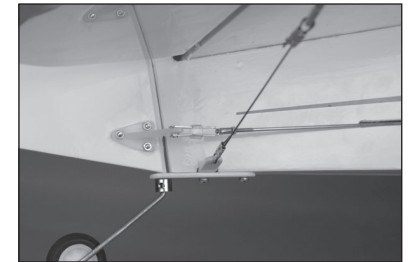

- 122.** Repeat the procedure to install the elevator pushrod.



WINDSHIELD PREPARATION

123. Use medium CA to glue the windshield supports into position. The following photos show the positioning of the supports.

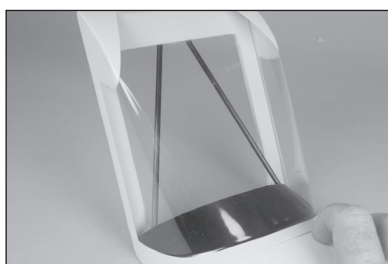
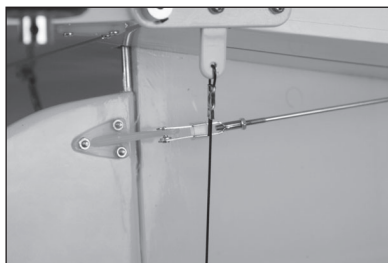

124. Use a hobby knife to remove the covering for the fuel cap.



125. Fit the fuel cap into position.

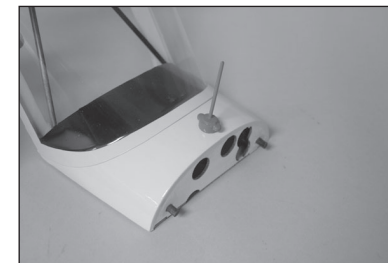

ELECTRIC MOTOR INSTALLATION

- Skip to the next section when installing a 4-stroke engine.

126. Attach the motor box to the firewall using four M4 washers and four M4 x 20mm socket head cap screws. Use threadlock on the blind nuts to prevent them from vibrating loose.



127. Use a #2 Phillips screwdriver to attach the X-mount to the rear of the motor. Use a 2.5mm hex wrench to attach the propeller adapter to the front of the motor. Use threadlock on all metal-to-metal fasteners to prevent them from vibrating loose.



128. Place a 3mm washer on a M3 x 15mm socket head cap screw. Use the screw to draw the blind nut into the back of the motor box firewall. Install all four blind nuts and remove the screws.



129. Attach the motor to the motor box using four 3mm washers and four M3 x 15mm socket head cap screws. Make sure to place a drop of threadlock on each screw before their installation to prevent them from vibrating loose.

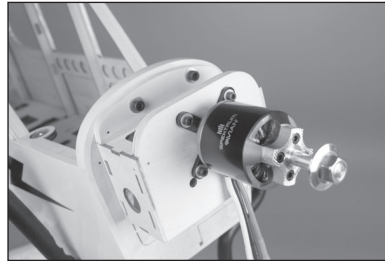
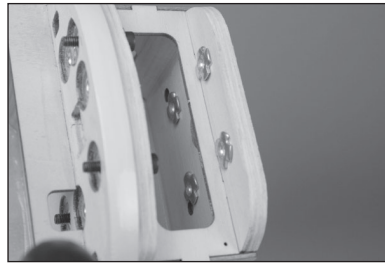

130. Route the motor leads inside the fuselage.



131. Connect the leads from the ESC to the motor. Secure the ESC inside the fuselage using hook and loop tape.



ENGINE INSTALLATION

132. Attach the engine mount to the firewall using four M4 x 25mm socket head screws and four M4 washers. Place a drop of threadlock on each screw before their installation. Use a 3mm hex wrench to tighten the screws once both mounts have been positioned correctly on the firewall.



133. Position the engine in the mounts so the drive washer is $4\frac{9}{16}$ inches (117mm) forward of the firewall. Use a clamp to hold the engine in position.

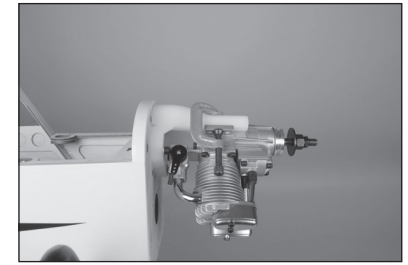

134. Remove the propeller, spinner and cowling from the boom. Use a felt-tipped pen to mark the location for the four engine mounting bolts on the engine mount.

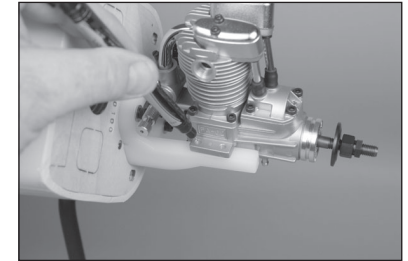

135. Use a felt-tipped pen to mark the location for the throttle pushrod.

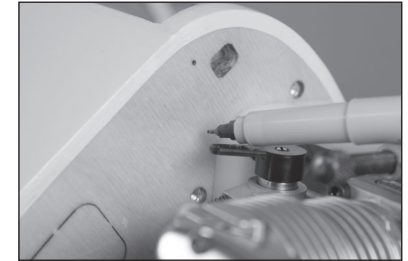

136. Remove the engine from the mounts. Use a drill and 1/8-inch (3mm) drill bit to drill the holes for the engine mounting screws. Once drilled, reattach the engine mounts to the firewall.

➔ We recommend removing the mounts from the firewall and using a drill press to drill the holes for best results.

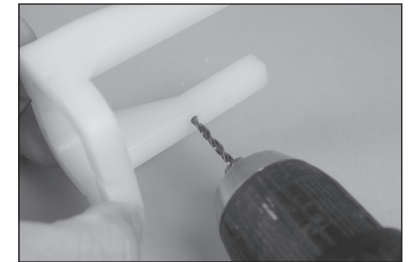

137. Use a 1/8-inch (3mm) drill bit top drill a hold in the firewall for the throttle pushrod.

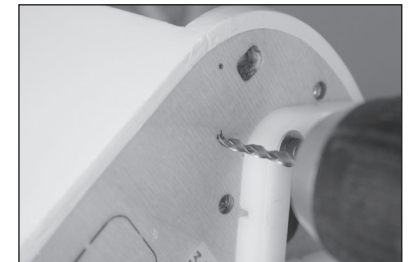

138. Use four M3 x 30mm machine screws to attach the engine to the mount. The M3 washers and M3 lock nuts are installed on the engine mount side during the engine installation. Use a 2.5mm hex wrench and 5.5mm hex driver to tighten all four screws, securing the engine to the engine mount.

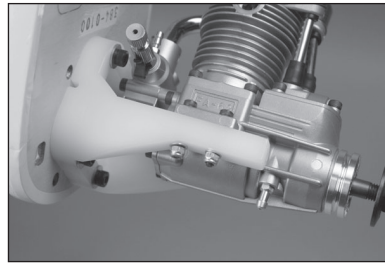

139. Slide the throttle pushrod into the hole in the firewall. Connect the clevis to the carburetor arm.

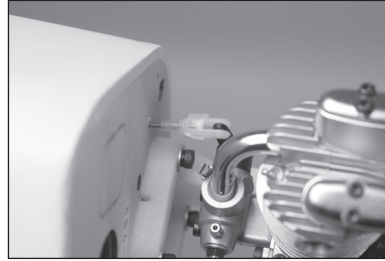

140. Install the throttle servo. With the stick and trim centered at the transmitter, place the servo arm on the servo so the arm closest the fuselage is aligned with the servo centerline. Remove any arms that may interfere with the operation of the servo.

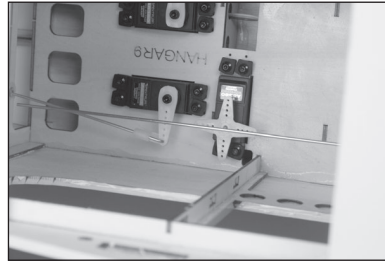

141. Mount the throttle servo connector in the throttle servo arm. Place a drop of canopy glue on the M2 nut, then install it on the underside of the arm to secure the connector.

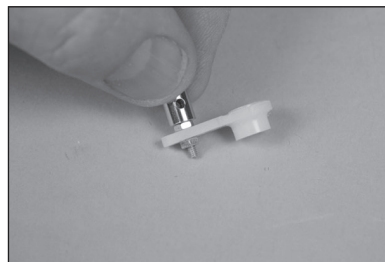
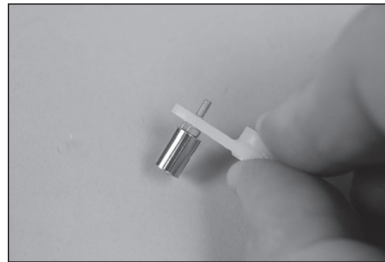

142. With the throttle stick and trim still centered, pass the throttle pushrod through the connector, then place the servo arm on the servo.

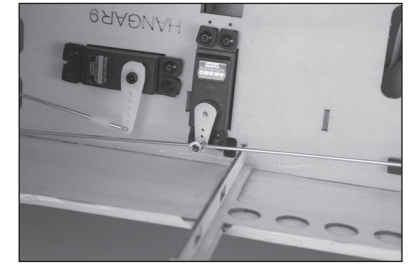

143. Manually open the carburetor. Move the throttle stick to full throttle. Tighten the setscrew to secure the pushrod in the connector.

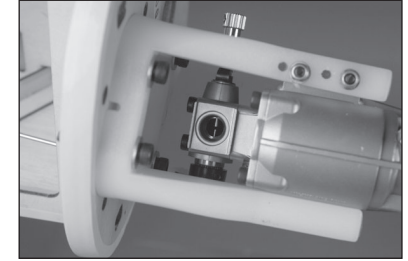

144. Secure the servo arm using the hardware provided with the servo.



145. Check the operation of the carburetor to make sure it opens fully, and the pushrod does not bind. Make any necessary adjustment to the linkage or in the radio programming if needed.



146. Secure a 12-inch (300mm) fuel line to the fill, vent and clunk tubes of the fuel tank.

→ Cable ties or the included clips can be used to secure the fuel tubing when using a gas engine.

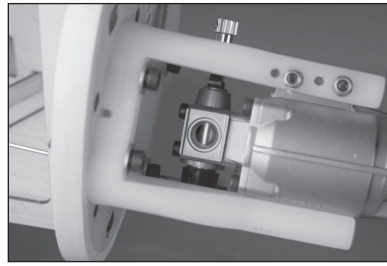

147. Secure the fuel tank in the fuselage using the hook and loop straps.

→ Use hook and loop tape or a thin layer of foam rubber to keep the fuel tank from sliding during flight.

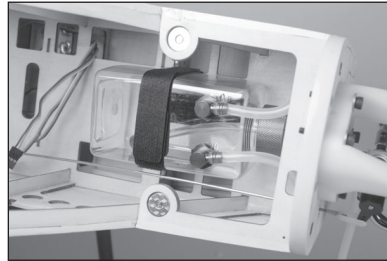
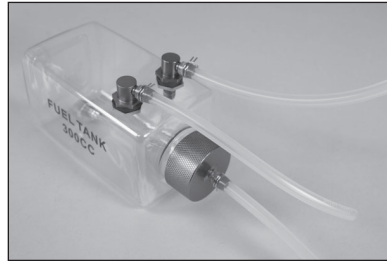

148. Connect the tubing from the clunk to the carburetor.

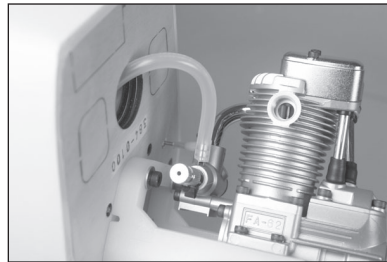

COWLING INSTALLATION

149. Cut a piece of card stock and make an opening locating the valve cover of the engine. Tape the card stock to the side of the fuselage.



→ The engine may need to be removed for the following step.

150. Slide the cowling into position. Use the template to trace the location for the valve cover on the cowling.

→ The engine can be reinstalled once the step has been completed.

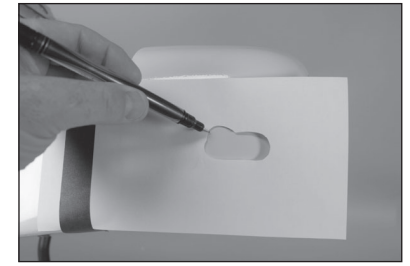

151. Trim the cowling to fit over the valve cover of the engine.

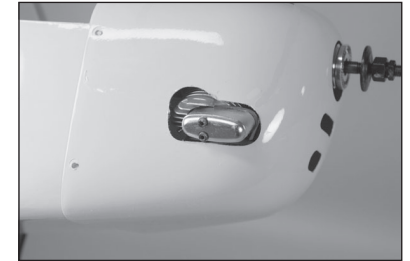

152. Secure the propeller to the engine shaft. Position the cowl so there is a 1/8-inch (3mm) gap between the propeller and cowling.

→ Use low-tack tape to hold the cowling in position for the following step.



153. Use a drill and 1/16-inch (1.5mm) drill bit to drill the locations in the fuselage for the cowl mounting screws.



154. Secure the cowling using four M3 x 10mm sheet metal screws to secure the cowling to the fuselage.

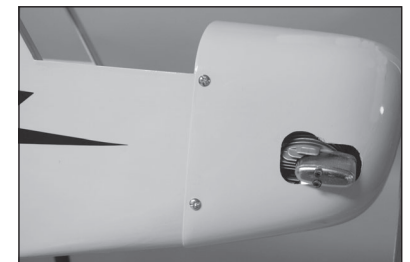

- 155.** The dummy engine can be attached to the cowling using silicone adhesive. Trim the dummy engine as necessary to clear any parts of the engine that may interfere with its placement. Use low-tack tape to hold it in position until the adhesive fully cures.



- 156.** Install the muffler and connect the vent line from the fuel tank. Trim the cowling as needed to allow clearance for the muffler.

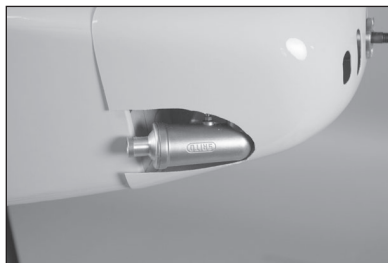

WINDOW INSTALLATION

- 157.** Use hobby scissors to trim the hatch window as necessary to fit into the hatch. Use canopy glue to secure the hatch window inside the hatch. Use low-tack tape to hold the hatch window in position until the adhesive fully cures.

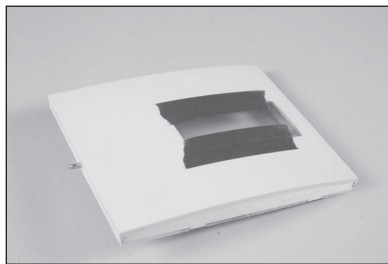

- 158.** Use hobby scissors to trim the three window sections as necessary to fit into the fuselage. Use canopy glue to secure the windows inside the fuselage. Use low-tack tape to hold the windows in position until the adhesive fully cures.

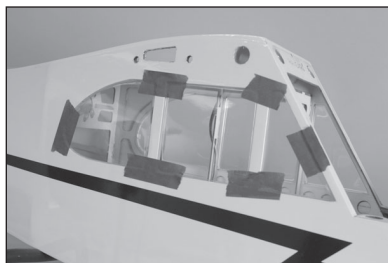

- ➔ Continue on Page 26 starting with “Battery and Receiver Installation” to complete building the ARF version of the J-3 Cub 10cc.

EMPENNAGE INSTALLATION

- 159.** Remove the M3 lock nut and M3 washer from the threaded rods installed in the fin.

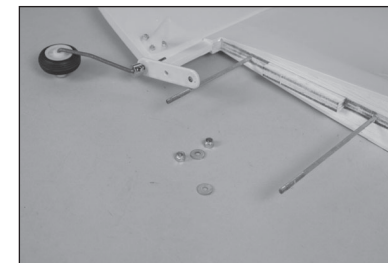

- 160.** Insert the threaded rods from the fin into the holes in the stabilizer. Note the covering has been removed on the top of the stabilizer so the fin can fit into position.



- 161.** Slide the threaded rods into the fuselage. Make sure to guide the tail bracket as necessary to fit the fin and rudder into position.

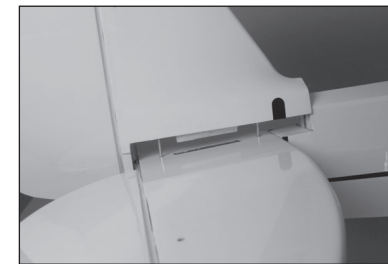

- 162.** Place the M3 washers on the threaded rods, then thread the M3 lock nuts on the threaded rods. The bracket with the tail rigging is then positioned between the tail support and fuselage. Tighten the lock nuts using a 5.5mm nut driver. Use care not to over-tighten the hardware and damage any of the surrounding structures.

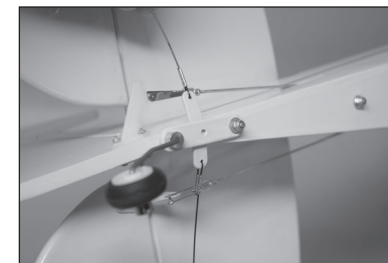

- 163.** Secure the tail rigging bracket using an M3 x 10 sheet metal screw.

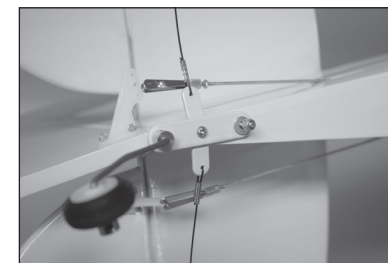

164. Slide an M3 x 14mm socket head screw through the pre-bent aluminum cable tab. Slide the screw through the hole in the top side of the stabilizer.



165. Slide a second tab on the screw from the bottom of the stabilizer. Secure the tabs using an M3 lock nut.

→ Install tabs on the left and right of the stabilizer. The tabs for the fin will have the cables pre-attached.

→ Do not overtighten the hardware and compress the wood structure of the stabilizer or fin.

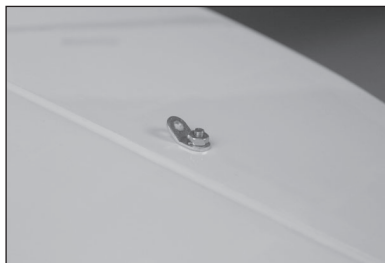

166. Attach the clevises to the tabs on the top of the stabilizer.

→ When installing the cable ends, make sure the cable does not loop over and get stuck on the fitting.



167. Attach the clevises to the tabs on the bottom of the stabilizer. Adjust the clevises so there is light tension on each cable, yet it does not distort the positioning of the stabilizer or fin.



168. Attach the clevis to the rudder control horn. Slide the clevis retainer over the forks of the clevis.



169. Attach the clevis to the elevator control horn. Slide the clevis retainer over the forks of the clevis.



WING INSTALLATION

170. Attach the strut mounting tabs to the fuselage using four M3 x 10mm socket head cap screws and a 1.5mm hex wrench.



171. Slide the wing tube into the wing tube socket.



172. Remove the windshield hatch from the fuselage. It is secured quite firmly with four magnet retainers. You may find it easier to grip each side of the windshield towards the top, and pull forward. Another good method is to separate the top of the hatch with a thin plastic wedge.

→ Avoid picking at the top edge, as it may be possible to separate the windshield from the frame.

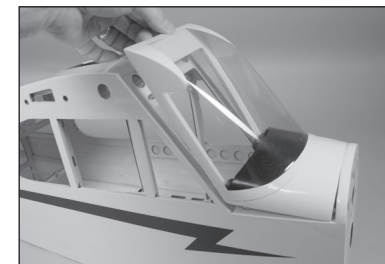

173. Fit the fuel cap into position.

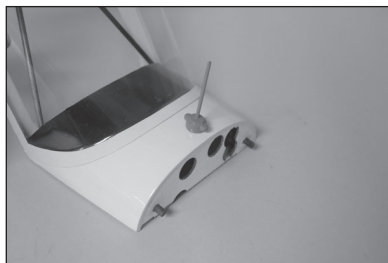

174. The top hatch has an internal spring-loaded latch. Release the hatch by pulling the latch forward, then pushing upwards.

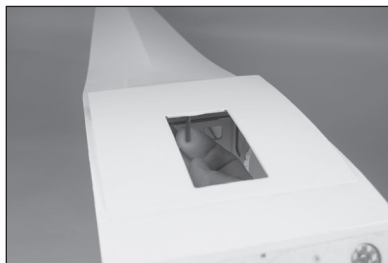

175. Slide the wing tube in the socket in the fuselage.

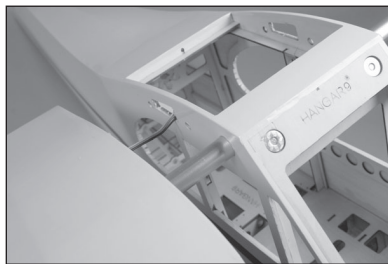

176. Slide the wing panel tight against the fuselage, guiding the aileron lead into the fuselage. Secure the wing panel using the 1/4-20 nylon wing bolt.



177. The jury strut ends will fit into the holes in the underside of the wing.



178. Adjust the strut end so the hole in the strut end aligns with the hole in the mounting tab. The strut end fit underneath the tab. Insert the pin from the fuselage side and slide the retaining clip through the hole in the pin.

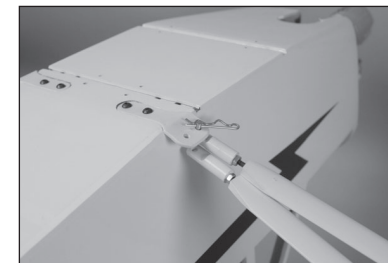

→ When the fuselage is supported inverted, the weight of the wings will naturally set the correct dihedral. Adjust the strut ends in this position. When/if assembling the model upright, this will cause the strut ends to not quite align, which is normal. Use slight pressure to align the holes, then insert the pins.

179. Repeat the above process for the remaining strut.

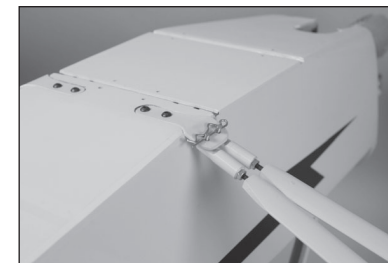

180. With the strut attached, use needle nose pliers to tighten the nuts against the strut end fittings to keep them from vibrating loose.

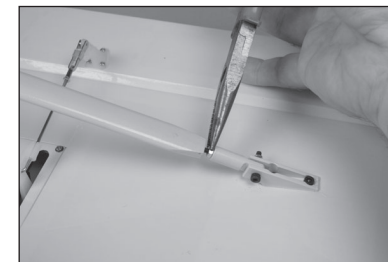

→ Use threadlock on all metal-to-metal fasteners.

→ Install the remaining wing panel before proceeding.

181. Remove the wing panels from the fuselage. Place the foam tubing on the jury struts to prevent damage to the wing during transport or storage.



LANDING GEAR INSTALLATION

182. Use a file to make two 1/2-inch (13mm) wide flat areas on the bottom of the axle. The first area is near the gear, and the second is near the end of the axle.

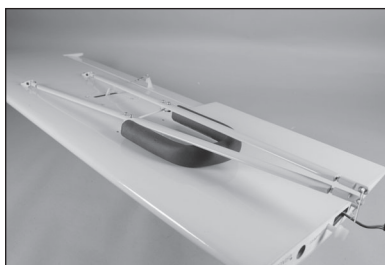

183. Slide a wheel collar on the axle.

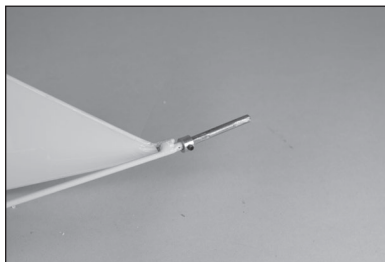

184. Inspect the wheel. One side has three holes to attach the hub cap to the wheel. These holes need to face toward the outside of the landing gear.



185. Slide the wheel on the axle.

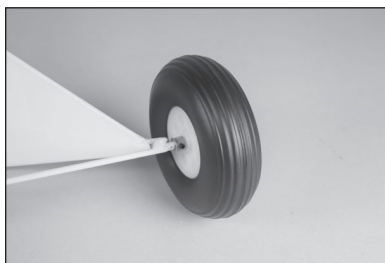

186. Slide a wheel collar on the axle. Tighten the setscrew so the wheel collar is flush with the end of the axle.

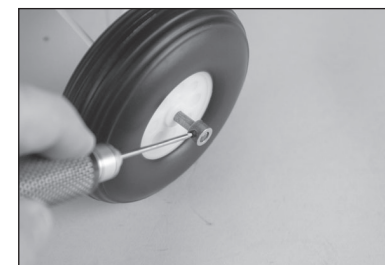

187. Slide the inside wheel collar against the wheel and tighten the setscrew. Make sure the wheel can rotate freely.

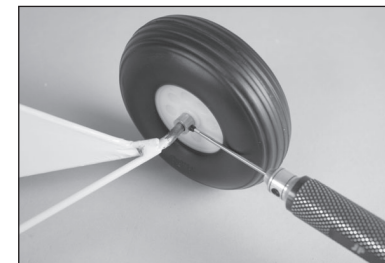

188. Attach the hub cap using three M2 x 6mm countersunk screws. Use a #1 Phillips screwdriver to tighten the screws.



189. DuBro J-3 wheels can be installed as an option. Make sure to follow the instructions included with the wheels.

→ The axle will need to be shimmed. This can be done with a wrap of aluminum tape, in the forward-rotation direction. Another option is thin-wall tubing. The axle will also require trimming to length, approximately 37mm, to allow installation of the hubcap.

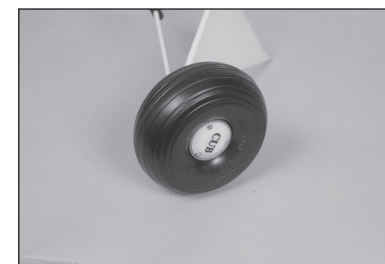

190. Attach the landing gear to the fuselage using two flat landing gear straps at the rear and two saddle straps at the front. Secure the straps using eight M3 x 10 sheet metal screws.



BATTERY AND RECEIVER INSTALLATION

191. Place the battery in the fuselage, and use the hook and loop strap to secure the battery. Make sure not to cover any warning labels on the battery.

→ The placement of the battery can be changed to adjust the Center of Gravity. Once adjusted, mark the location of the battery so it can be returned to the correct location when installed after charging.

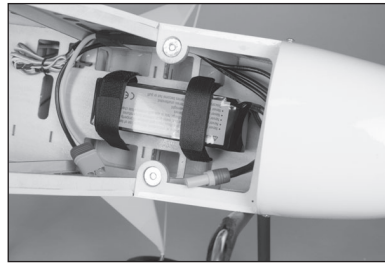

192. Install the receiver in the fuselage using double-sided foam tape. Refer to the receiver instructions for more details on mounting the receiver and routing the antenna. Connect the leads to the appropriate channels of the receiver.



This step is for the ARF only.

193. Plug the extensions for the aileron servos into the receiver. Route the leads for the ailerons through the holes in the formers and through the openings in the sides of the fuselage.



194. Glue the seat(s) in the cockpit using contact adhesive, or hook and loop tape. Position the seats between the battery and receiver.



FLOAT INSTALLATION

195. Assemble the floats following the instructions included with the floats. Use the mounting positions shown for the strut mounting locations.

→ The front bracket will be in the rear position, and the rear bracket will be in the front position.

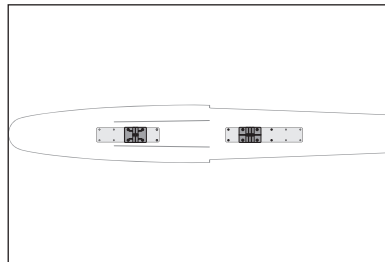

196. Three struts are installed in the rear bracket. From front to back these are; diagonal strut, rear strut with bushing, spreader bar.

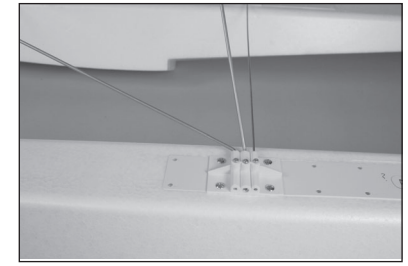

→ The rear strut uses a bushing to allow the strut to properly fit to the correct diameter in the bracket. These bushings are supplied with the float strut set.

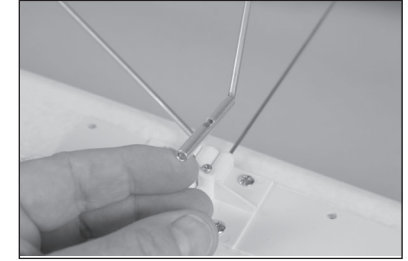

197. The forward bracket receives the forward strut, and a spreader bar, in that order.

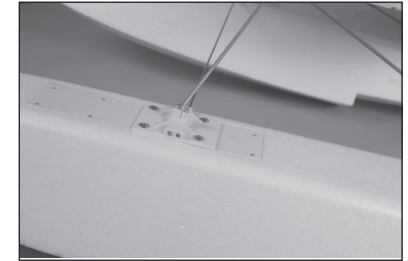

198. Use a hobby knife and #11 blade to cut a slit in the covering for the rear strut. Use a covering iron to seal the covering into the slot.

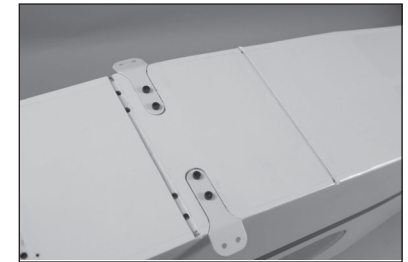

199. Fit the strut and diagonal strut in the forward slot. Secure the two struts using two landing gear straps and four M3 x 10 sheet metal screws.

→ The strut and diagonal strut stack in the slot, and use the same saddle clamps as the landing gear.



200. Locate the four holes for the landing gear straps on the bottom of the fuselage. Use a hobby knife and #11 blade to expose the holes. Secure the rear strut using two landing gear straps and four M3 x 10 sheet metal screws.

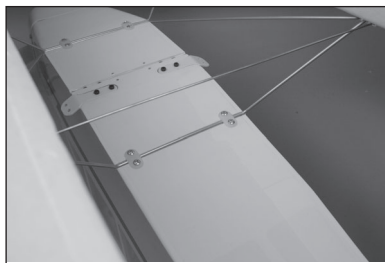

201. Use tape to secure the lead for the water rudder to the float and strut so it doesn't interfere with the operation of the model.

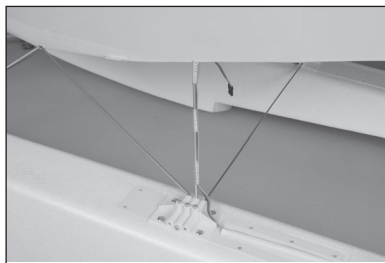

202. The float steering servo lead will reach the receiver without an extension lead in most installations. One option to route the lead is to simply cut a small slit in the covering above the float strut. Apply a piece of Blenderm™ tape before cutting, this will prevent the covering from tearing. Another option is to use a receptacle in the opening, and plug the float servo into the receptacle. Plug the float servo into an open channel in the receiver. Mix the rudder servo to the float servo for correct operation.

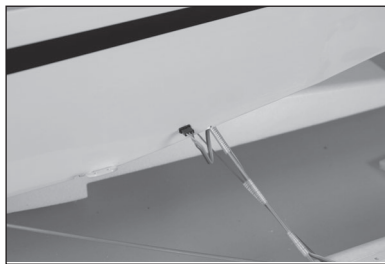

DECAL INSTALLATION

203. Apply the decals to your model using the box art from your model as a guide to location. The internet is also a great resource for decal placement. Use a spray bottle and a drop of dish washing liquid or glass cleaner sprayed in the location of the decal to allow repositioning of the decal. Use a paper towel as a squeegee to remove excess water from under the decal. Allow the model to rest overnight so the remaining water can evaporate.

→ When cleaning your model, do not use harsh chemicals on the provided decals. Test on unused decals first.

CENTER OF GRAVITY

 **CAUTION:** You must adjust your aircraft's center of gravity and balance your model properly before attempting flights.

An important part of preparing the aircraft for flight is properly balancing the model. The Center of Gravity range supplied here is a guideline based on testing. Deviation from the measurements we provide is possible and may result in a model that suits your flying style better. Start with the recommended Center of Gravity, then feel free to experiment with different balance points. We advise adjusting progressively and cautiously.

1. Attach the wing panels to the fuselage. Make sure to connect the leads from the aileron and flaps to the appropriate leads from the receiver. Make sure the leads are not exposed outside the fuselage before tightening the wing bolts. Your model should be flight-ready before balancing.
 2. The recommended Center of Gravity (CG) location for your model is $3\frac{3}{8}$ inches (85mm) behind the leading edge of the wing against the fuselage for sport flying.
 3. When balancing your model, make sure it is assembled and ready for flight. Support the plane upright at the marks made on the wing with your fingers or a commercially available balancing stand. Use the radio system to move the gear to the up position.
- The overall CG range for this model is $3-3\frac{3}{4}$ inches (76–95mm) as shown below. We recommend starting at the measurement listed above, then adjusting to suit your particular flying style.
- Nose weight may be required when using lighter engines or when floats are installed.

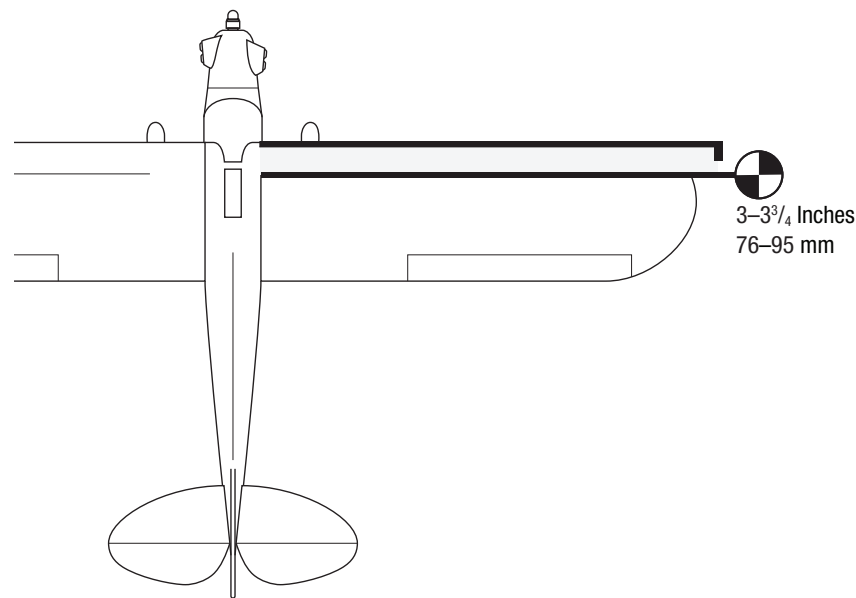

CONTROL THROWS

1. Turn on the transmitter and receiver of your model. Check the movement of the rudder using the transmitter. When the stick is moved to the right, the rudder should also move right. Reverse the direction of the servo at the transmitter if necessary.
2. Check the movement of the elevator with the radio system. Moving the elevator stick toward the bottom of the transmitter will make the airplane elevator move up.
3. Check the movement of the ailerons with the radio system. Moving the aileron stick to the right will make the right aileron move up and the left aileron move down.
4. Use a ruler to adjust the throw of the elevator, ailerons and rudder.

Surface	Rate	Direction	Throw
Aileron	High	Up	1 ³ / ₁₆ inch (30 mm)
		Down	13/16 inch (20 mm)
	Low	Up	7/8 inch (22 mm)
		Down	5/8 inch (15 mm)
Elevator	High	Up	2 ³ / ₁₆ inch (55 mm)
		Down	2 ³ / ₁₆ inch (55 mm)
	Low	Up	1 ¹ / ₂ inch (38 mm)
		Down	1 ¹ / ₂ inch (38 mm)
Rudder	High	Left	2 ³ / ₈ inch (60 mm)
		Right	2 ³ / ₈ inch (60 mm)
	Low	Left	1 ⁹ / ₁₆ inch (40 mm)
		Right	1 ⁹ / ₁₆ inch (40 mm)

These are guidelines from general flying from our own flight tests. You can experiment with higher or lower rates to match your preferred style of flying.

Travel Adjust should be adjusted according to each individual model and preference. Always install the control horns 90 degrees to the pushrod at the servo. Use sub-trim as a last resort to center the servos.

Always re-bind the radio system once all the control throws are set to keep the servos from moving to their endpoints until the transmitter and receiver connect.

PREFLIGHT CHECKLIST

- Charge the transmitter, receiver and motor batteries. Follow the instructions provided with the charger. Follow all manufacturer's instructions for your electronic components.
- Check the radio installation and make sure all control surfaces (aileron, elevator, rudder, and flaps) move correctly (i.e., the correct direction and with the recommended throws).
- Check all the hardware (control horns, servo horns, and clevises) to make sure they are secure and in good condition.
- Prior to each flying session (and especially with a new model), perform a range check of your radio system. See your radio manual for the recommended range and instructions for your particular radio system.

DAILY FLIGHT CHECKS

- Check the battery voltage of the transmitter battery. Do not fly below the manufacturer's recommended voltage. Doing so can cause your aircraft to crash.
- Check all hardware (linkages, screws, nuts, and bolts) prior to each day's flight. Ensure that binding does not occur and that all parts are properly secured.
- Ensure all surfaces are moving in the proper manner.
- Perform a ground range check before each day's flying session.
- All servo leads and switch harness plugs should be secured in the receiver.

LIMITED WARRANTY

What this Warranty Covers

Horizon Hobby, LLC, (Horizon) warrants to the original purchaser that the product purchased (the "Product") will be free from defects in materials and workmanship at the date of purchase.

What is Not Covered

This warranty is not transferable and does not cover (i) cosmetic damage, (ii) damage due to acts of God, accident, misuse, abuse, negligence, commercial use, or due to improper use, installation, operation or maintenance, (iii) modification of or to any part of the Product, (iv) attempted service by anyone other than a Horizon Hobby authorized service center, (v) Product not purchased from an authorized Horizon dealer, (vi) Product not compliant with applicable technical regulations, or (vii) use that violates any applicable laws, rules, or regulations.

OTHER THAN THE EXPRESS WARRANTY ABOVE, HORIZON MAKES NO OTHER WARRANTY OR REPRESENTATION, AND HEREBY DISCLAIMS ANY AND ALL IMPLIED WARRANTIES, INCLUDING, WITHOUT LIMITATION, THE IMPLIED WARRANTIES OF NON-INFRINGEMENT, MERCHANTABILITY AND FITNESS FOR A PARTICULAR PURPOSE. THE PURCHASER ACKNOWLEDGES THAT THEY ALONE HAVE DETERMINED THAT THE PRODUCT WILL SUITABLY MEET THE REQUIREMENTS OF THE PURCHASER'S INTENDED USE.

Purchaser's Remedy

Horizon's sole obligation and purchaser's sole and exclusive remedy shall be that Horizon will, at its option, either (i) service, or (ii) replace, any Product determined by Horizon to be defective. Horizon reserves the right to inspect any and all Product(s) involved in a warranty claim. Service or replacement decisions are at the sole discretion of Horizon. Proof of purchase is required for all warranty claims. SERVICE OR REPLACEMENT AS PROVIDED UNDER THIS WARRANTY IS THE PURCHASER'S SOLE AND EXCLUSIVE REMEDY.

Limitation of Liability

HORIZON SHALL NOT BE LIABLE FOR SPECIAL, INDIRECT, INCIDENTAL OR CONSEQUENTIAL DAMAGES, LOSS OF PROFITS OR PRODUCTION OR COMMERCIAL LOSS IN ANY WAY, REGARDLESS OF WHETHER SUCH CLAIM IS BASED IN CONTRACT, WARRANTY, TORT, NEGLIGENCE, STRICT LIABILITY OR ANY OTHER THEORY OF LIABILITY, EVEN IF HORIZON HAS BEEN ADVISED OF THE POSSIBILITY OF SUCH DAMAGES. Further, in no event shall the liability of Horizon exceed the individual price of the Product on which liability is asserted. As Horizon has no control over use, setup, final assembly, modification or misuse, no liability shall be assumed nor accepted for any resulting damage or injury. By the act of use, setup or assembly, the user accepts all resulting liability. If you as the purchaser or user are not prepared to accept the liability associated with the use of the Product, purchaser is advised to return the Product immediately in new and unused condition to the place of purchase.

Law

These terms are governed by Illinois law (without regard to conflict of law principals). This warranty gives you specific legal rights, and you may also have other rights which vary from state to state. Horizon reserves the right to change or modify this warranty at any time without notice.

WARRANTY SERVICES

Questions, Assistance, and Services

Your local hobby store and/or place of purchase cannot provide warranty support or service. Once assembly, setup or use of the Product has been started, you must contact your local distributor or Horizon directly. This will enable Horizon to better answer your questions and service you in the event that you may need any assistance. For questions or assistance, please visit our website at www.horizonhobby.com, submit a Product Support Inquiry, or call the toll free telephone number referenced in the Warranty and Service Contact Information section to speak with a Product Support representative.

Inspection or Services

If this Product needs to be inspected or serviced and is compliant in the country you live and use the Product in, please use the Horizon Online Service Request submission process found on our website or call Horizon to obtain a Return Merchandise Authorization (RMA) number. Pack the Product securely using a shipping carton. Please note that original boxes may be included, but are not designed to withstand the rigors of shipping without additional protection. Ship via a carrier that provides tracking and insurance for lost or damaged parcels, as Horizon is not responsible for merchandise until it arrives and is accepted at our facility. An Online Service Request is available at http://www.horizonhobby.com/content/service-center_render-service-center. If you do not have internet access, please contact Horizon Product Support to obtain a RMA number along with instructions for submitting your product for service. When calling Horizon, you will be asked to provide your complete name, street address, email address and phone number where you can be reached during business hours. When sending product into Horizon, please include your RMA number, a list of the included items, and a brief summary of the problem. A copy of your original sales receipt must be included for warranty consideration. Be sure your name, address, and RMA number are clearly written on the outside of the shipping carton.

NOTICE: Do not ship LiPo batteries to Horizon. If you have any issue with a LiPo battery, please contact the appropriate Horizon Product Support office.

Warranty Requirements

For Warranty consideration, you must include your original sales receipt verifying the proof-of-purchase date. Provided warranty conditions have been met, your Product will be serviced or replaced free of charge. Service or replacement decisions are at the sole discretion of Horizon.

Non-Warranty Service

Should your service not be covered by warranty, service will be completed and payment will be required without notification or estimate of the expense unless the expense exceeds 50% of the retail purchase cost. By submitting the item for service you are agreeing to payment of the service without notification. Service estimates are available upon request. You must include this request with your item submitted for service. Non-warranty service estimates will be billed a minimum of ½ hour of labor. In addition you will be billed for return freight. Horizon accepts money orders and cashier's checks, as well as Visa, MasterCard, American Express, and Discover cards. By submitting any item to Horizon for service, you are agreeing to Horizon's Terms and Conditions found on our website http://www.horizonhobby.com/content/service-center_render-service-center.

ATTENTION: Horizon service is limited to Product compliant in the country of use and ownership. If received, a non-compliant Product will not be serviced. Further, the sender will be responsible for arranging return shipment of the un-serviced Product, through a carrier of the sender's choice and at the sender's expense. Horizon will hold non-compliant Product for a period of 60 days from notification, after which it will be discarded.

10/15

WARRANTY AND SERVICE CONTACT INFORMATION







Country of Purchase	Horizon Hobby	Contact Information	Address
United States of America	Horizon Service Center (Repairs and Repair Requests)	servicecenter.horizonhobby.com/RequestForm/	2904 Research Road Champaign, IL 61822
	Horizon Product Support (Product Technical Assistance)	productsupport@horizonhobby.com 877-504-0233	
	Sales	websales@horizonhobby.com 800-338-4639	
European Union	Horizon Technischer Service	service@horizonhobby.eu	Hanskampring 9 D 22885 Barsbüttel, Germany
	Sales: Horizon Hobby GmbH	+49 (0) 4121 2655 100	

WEEE NOTICE



This appliance is labeled in accordance with European Directive 2012/19/EU concerning waste of electrical and electronic equipment (WEEE). This label indicates that this product should not be disposed of with household waste. It should be deposited at an appropriate facility to enable recovery and recycling.

SPECIFICATIONS • SPEZIFIKATIONEN • SPÉCIFICATIONS • SPECIFICHE

	82.5 in (2096 mm)
	56 in (1422 mm)
	9.6 lbs (4341 g)
	<ul style="list-style-type: none"> • 4-Stroke glow: 0.62 cu. in. (10.16 cc) • 4-Stroke gas: 0.66 cu. in. (10.88cc) • 4-Takt Verbrenner: 0,62 cu. in. (10,16 cc) • 4-Takt Benzin: 0,66 cu. in. (10,88 cc) • Méthanol à quatre temps : 10,16 cm³ (0,62 po³) • Essence à quatre temps : 10,88 cm³ (0,66 po³) • 4 tempi a candele: 10,16 cc (0,62 cu. in.) • 4 tempi a gas: 10,88 cc (0,66 cu. in.)
	<ul style="list-style-type: none"> • 4260-480Kv Brushless Outrunner • 4260-480Kv bürstenloser Außenläufer • Cage tournante sans balais 4260-480Kv • 4260-480Kv Brushless Outrunner
	<ul style="list-style-type: none"> • 4 channel (or greater) with 4-5 servos • 4 Kanäle (oder mehr) mit 4-5 Servos • 4 canaux (ou plus) avec 4 à 5 servos • 4 canali (o più) con 4-5 servo
	4 ⁹ / ₁₆ inches (117mm) ±1/16 inch (1.5mm)

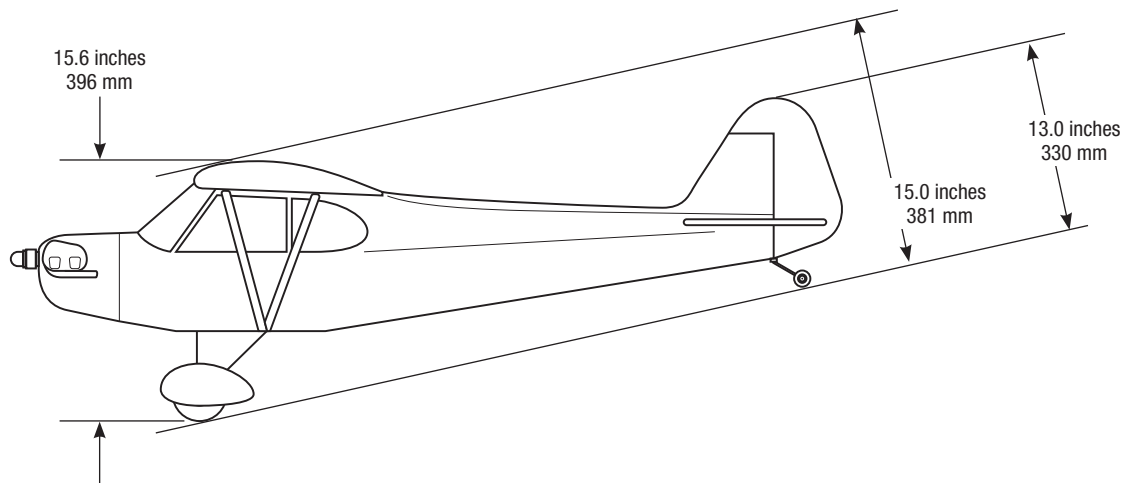
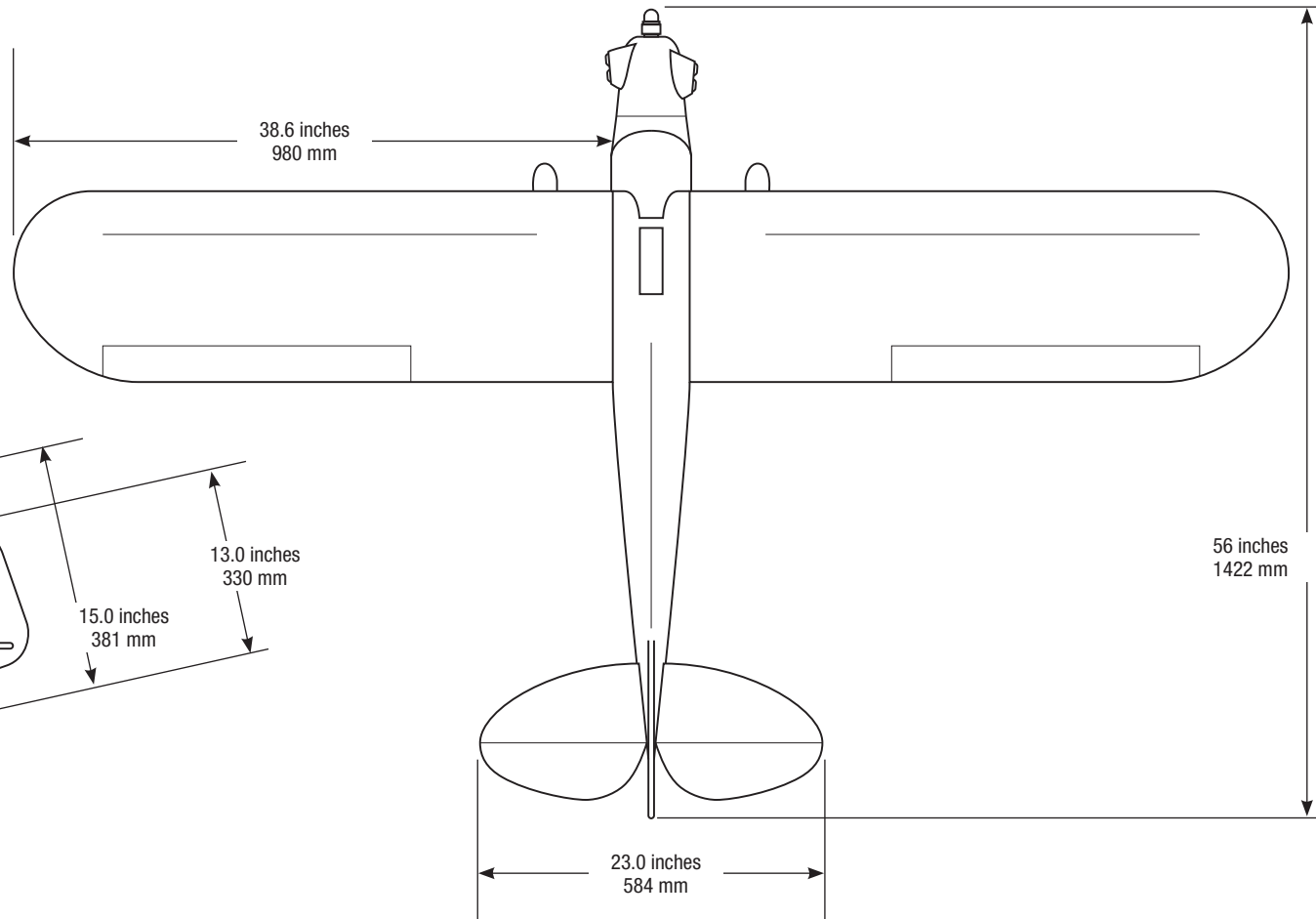
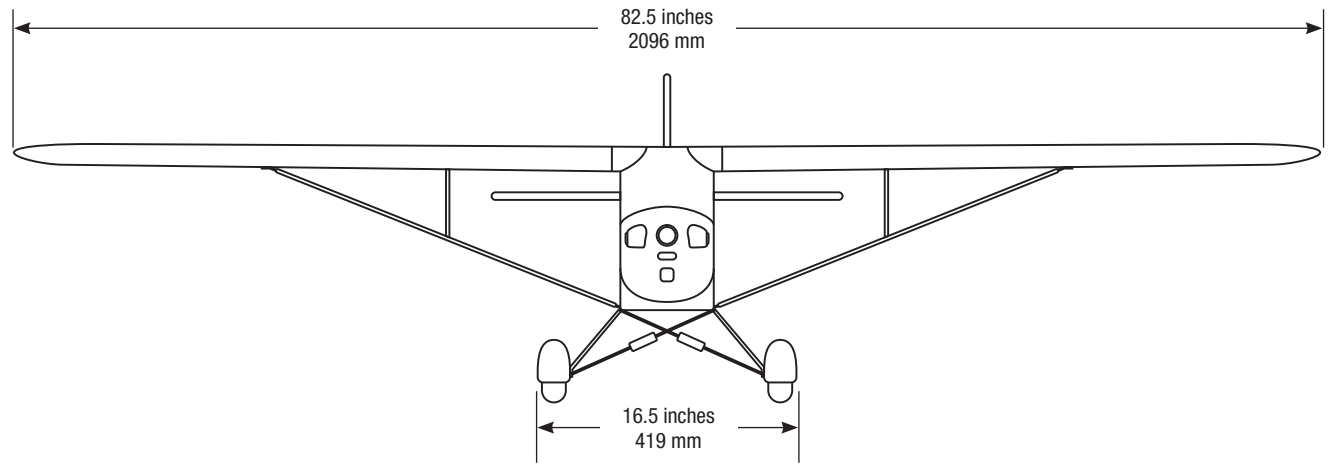

HANGAR 9[®]

© 2024 Horizon Hobby, LLC.

Hangar 9, Sky, AS3X, Avian, IC5, and the Horizon Hobby logo are trademarks or registered trademarks of Horizon Hobby, LLC.

The Spektrum trademark is used with permission of Bachmann Industries, Inc.

All other trademarks, service marks and logos are the property of their respective owners.

Created 08/2024

680332 HAN5005/HAN5175