



OMP HOBBY

Instruction Manual



Revision 0

OMP HOBBY **M7**



Table of Contents

Rotor Head Assembly	P 1	Landing Gear Installation	P 20
Control Chain Assembly	P 3	Motor Installation	P 21
Upper Frame Assembly	P 4	Vertical Tail Fin Installation	P 22
Installation of the Tensioner Screw	P 7	Tail Control Rod Installation	P 23
Drivetrain Assembly	P 8	Main Rotor Installation	P 25
Transmission Installation	P 9	Transmission Installation	P 26
Tail Rotor Head Installation	P 10	Rotor Blade Installation	P 28
Tail Assembly	P 11	Battery Installation	P 29
Tail Assembly Installation	P 14	ESC and Flight Controller Installation	P 30
Servo Installation	P 15	Canopy Installation	P 31
Lower Frame Assembly	P 16	Accessories, Operating Settings	P 32
Belt Tensioning Procedure	P 18	Sticker Installation	P 33
Lower Frame Assembly	P 19	Accessories package	P 34

Symbol Description



Note



Use AB Glue



Use Grease



Use Thread Lock



Indicates which numbered bag contains the parts needed for installation on this page.

BAG 1

01 Main Rotor Hub Assembly

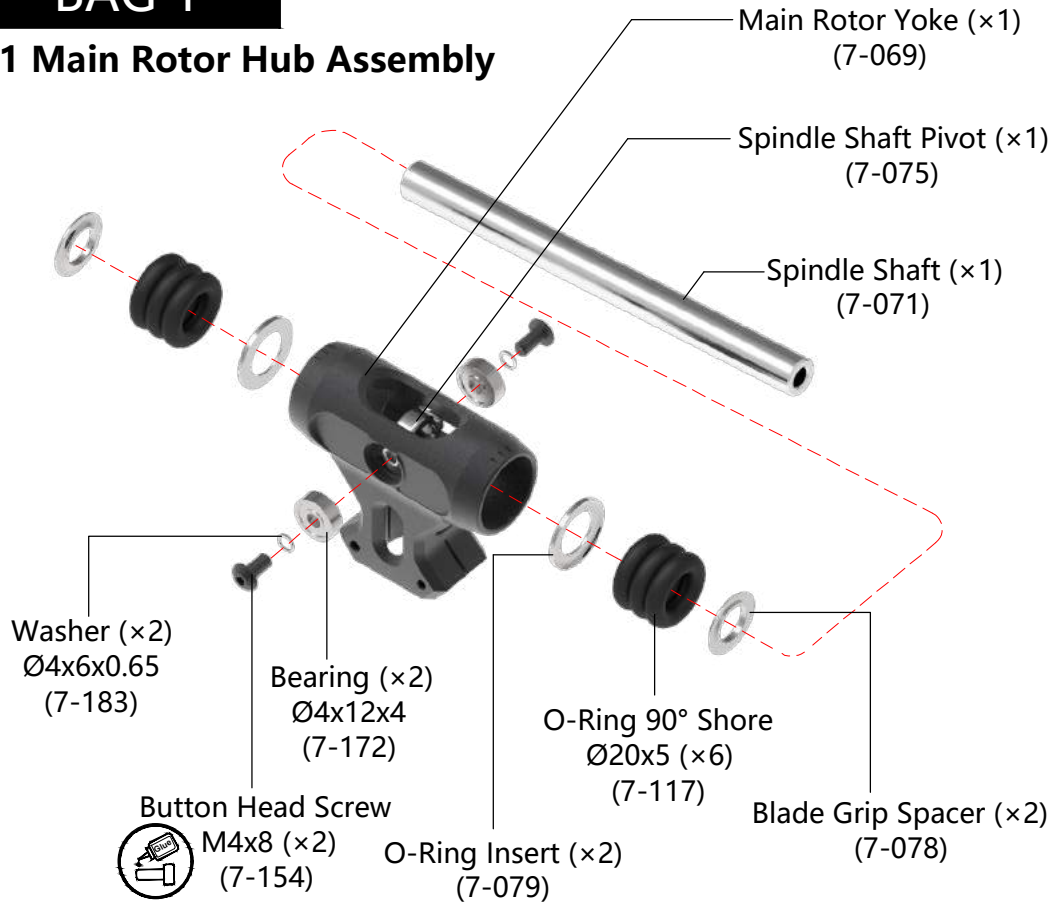

⚠ The spindle shaft pivot must be removed for use with POM dampers.

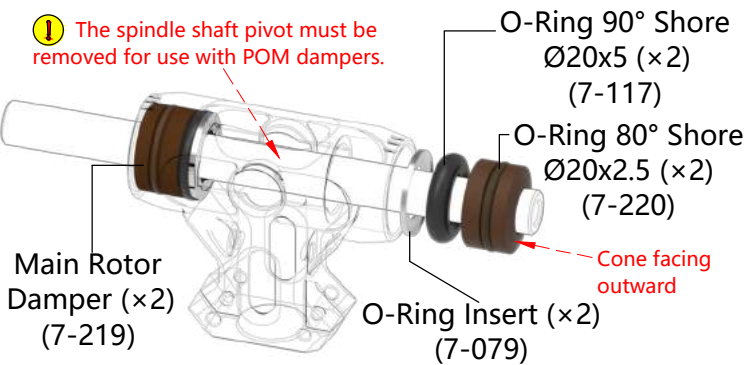

⚠ Your M7 comes with optional POM dampers for extremely hard response. POM dampers are made for high headspeeds and may cause adverse effects at medium to lower RPM, such as excessive control cross coupling, wobbling and in-flight resonance. Do not fly below 1100RPM with POM dampers installed. POM dampers are to be installed as shown. Do not use Blade Grip Spacer 7-078!

02 Main Rotor Blade Grip Assembly

⚠ The axial bearing cage's open side must face outward towards the rotor blade to prevent premature axial bearing failure.

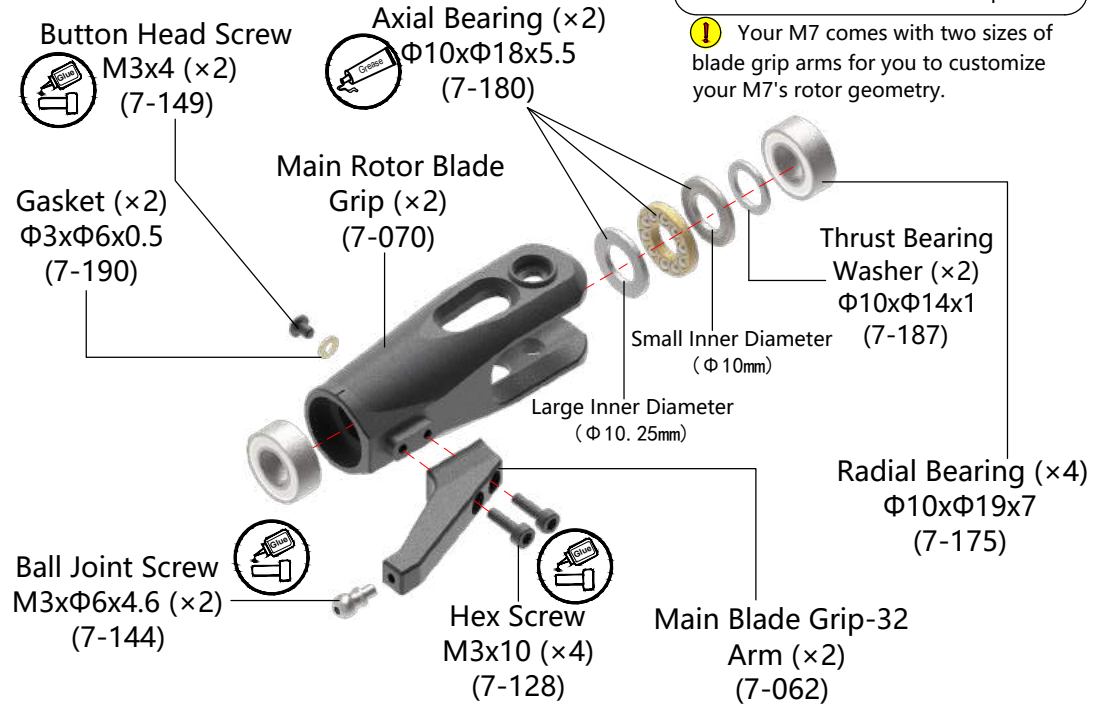

⚠ Your M7 comes with two sizes of blade grip arms for you to customize your M7's rotor geometry.

03 Main rotor head assembly

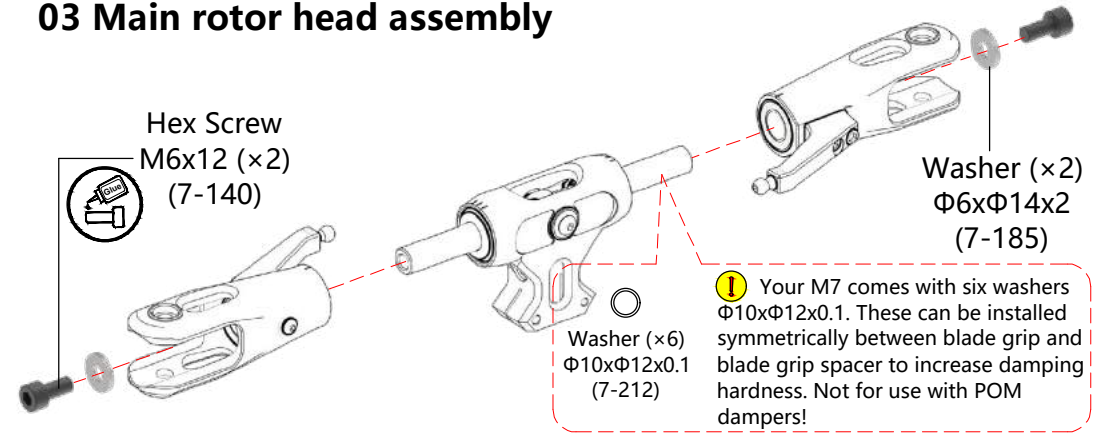

⚠ Your M7 comes with six washers $\text{Ø}10 \times \text{Ø}12 \times 0.1$. These can be installed symmetrically between blade grip and blade grip spacer to increase damping hardness. Not for use with POM dampers!

01 Swashplate Driver Arm Assembly

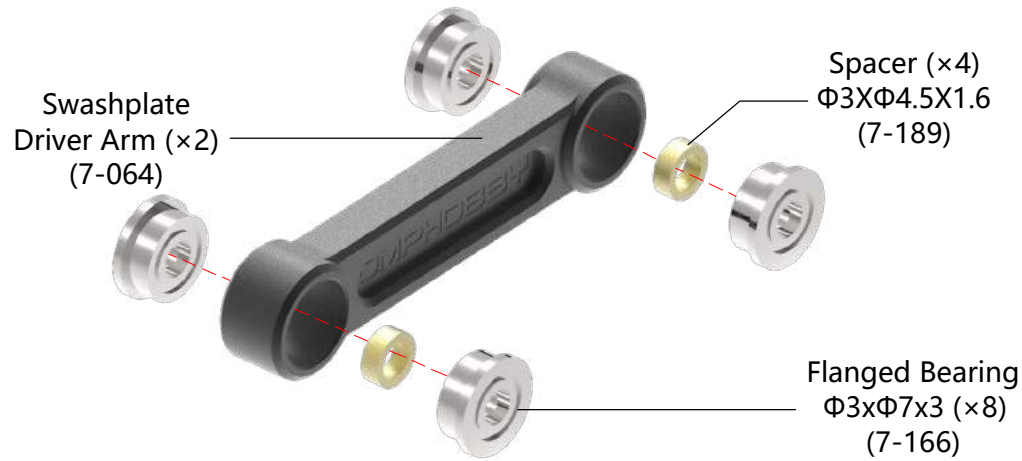

02 Swashplate Driver Joint Assembly

BAG 2

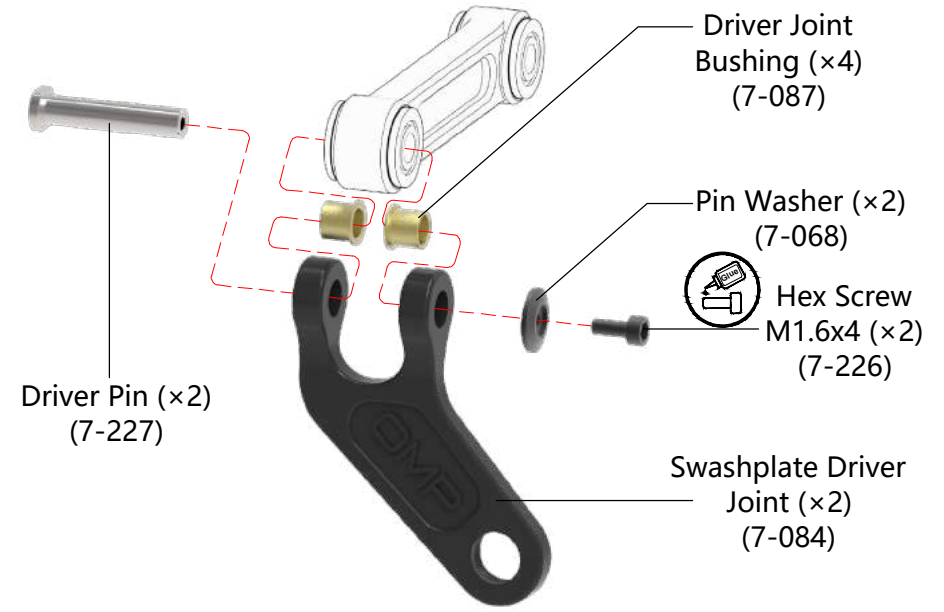

03 Swashplate Driver Installation

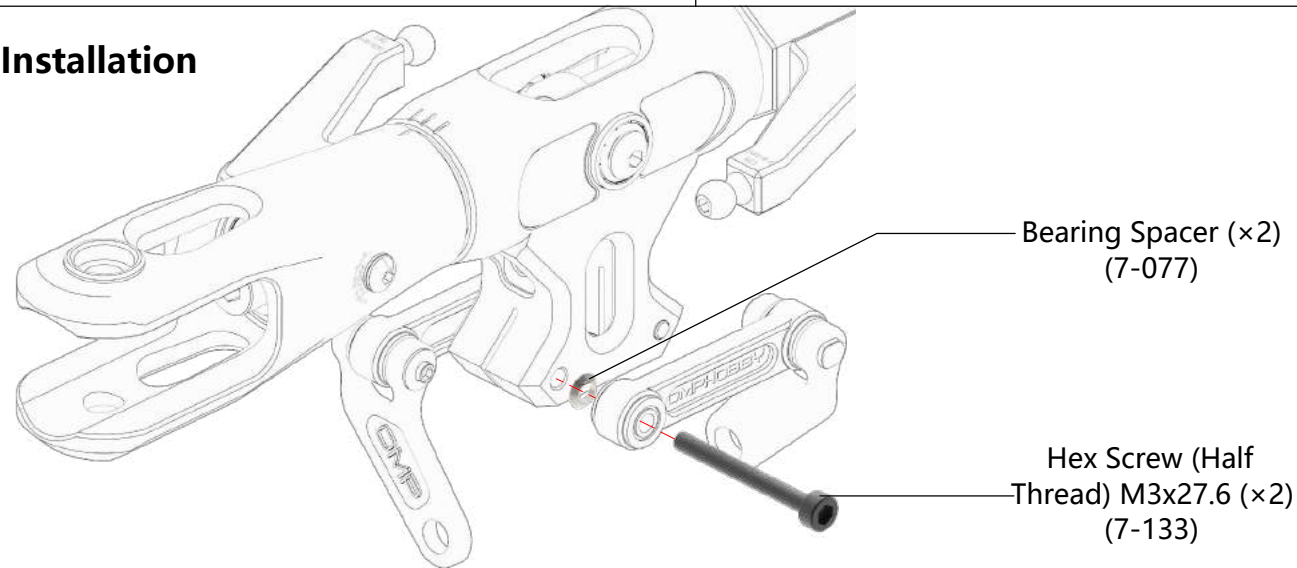

! Loosely assemble without Loctite!
The swashplate driver screws may only be tightened with Loctite once the main rotor assembly is installed on the main shaft.

BAG 3

01 Swashplate Assembly

! The swashplate is preassembled with Threadlock except for the ball joint screws!

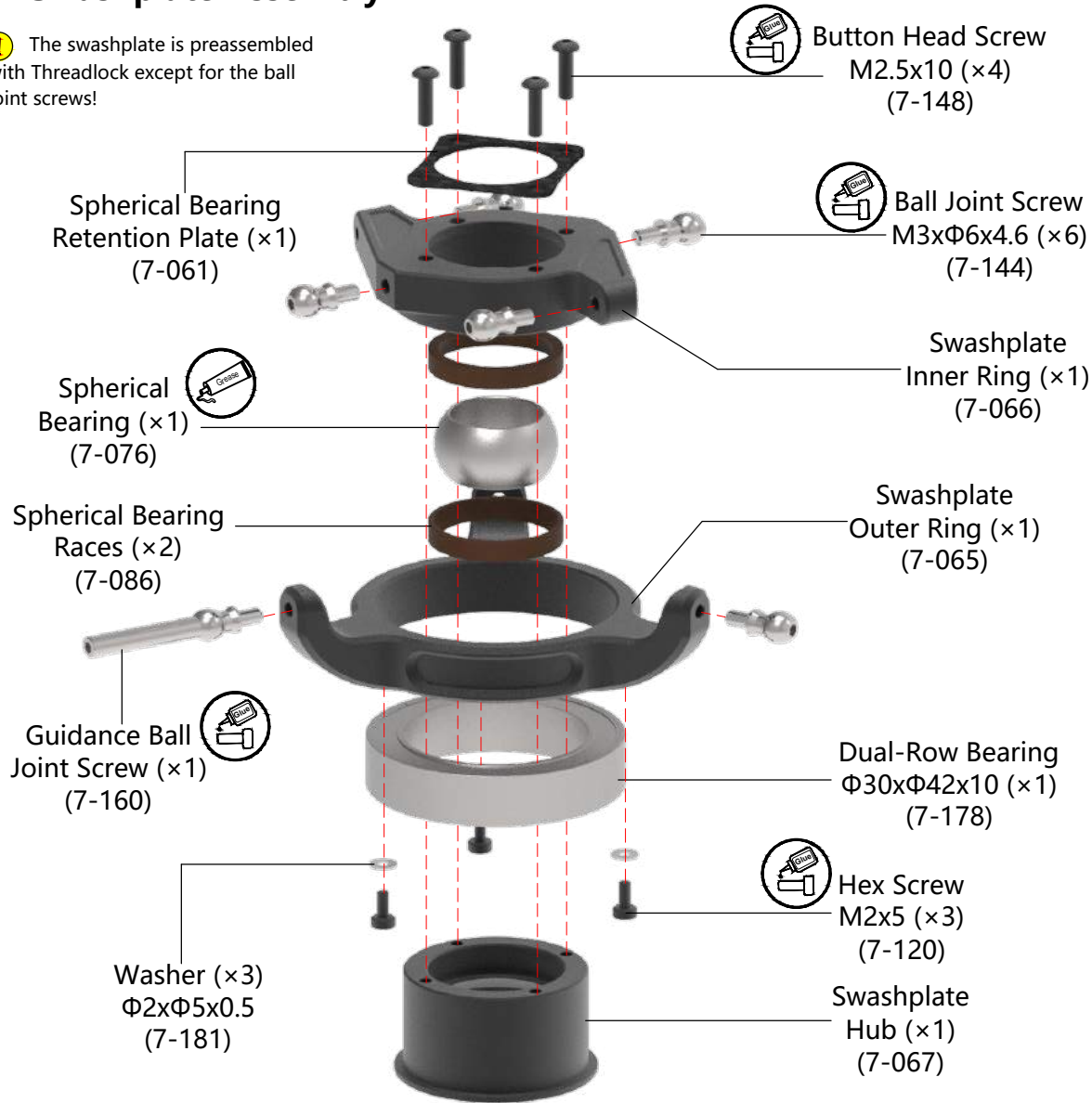

02 Control Linkage Assembly

! When assembling pay attention to the CW thread and CCW thread connections between the connecting rod and the ball head.

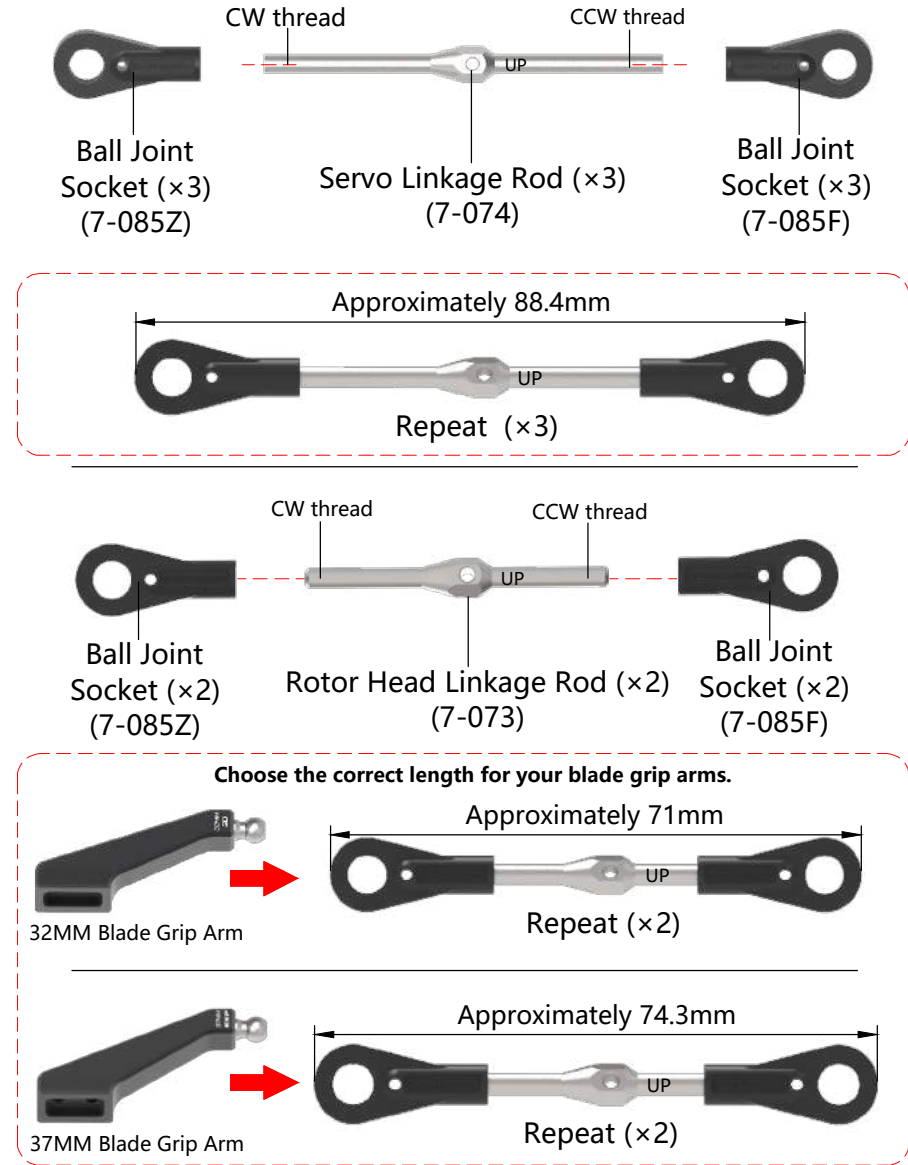

01 Central Dome Assembly

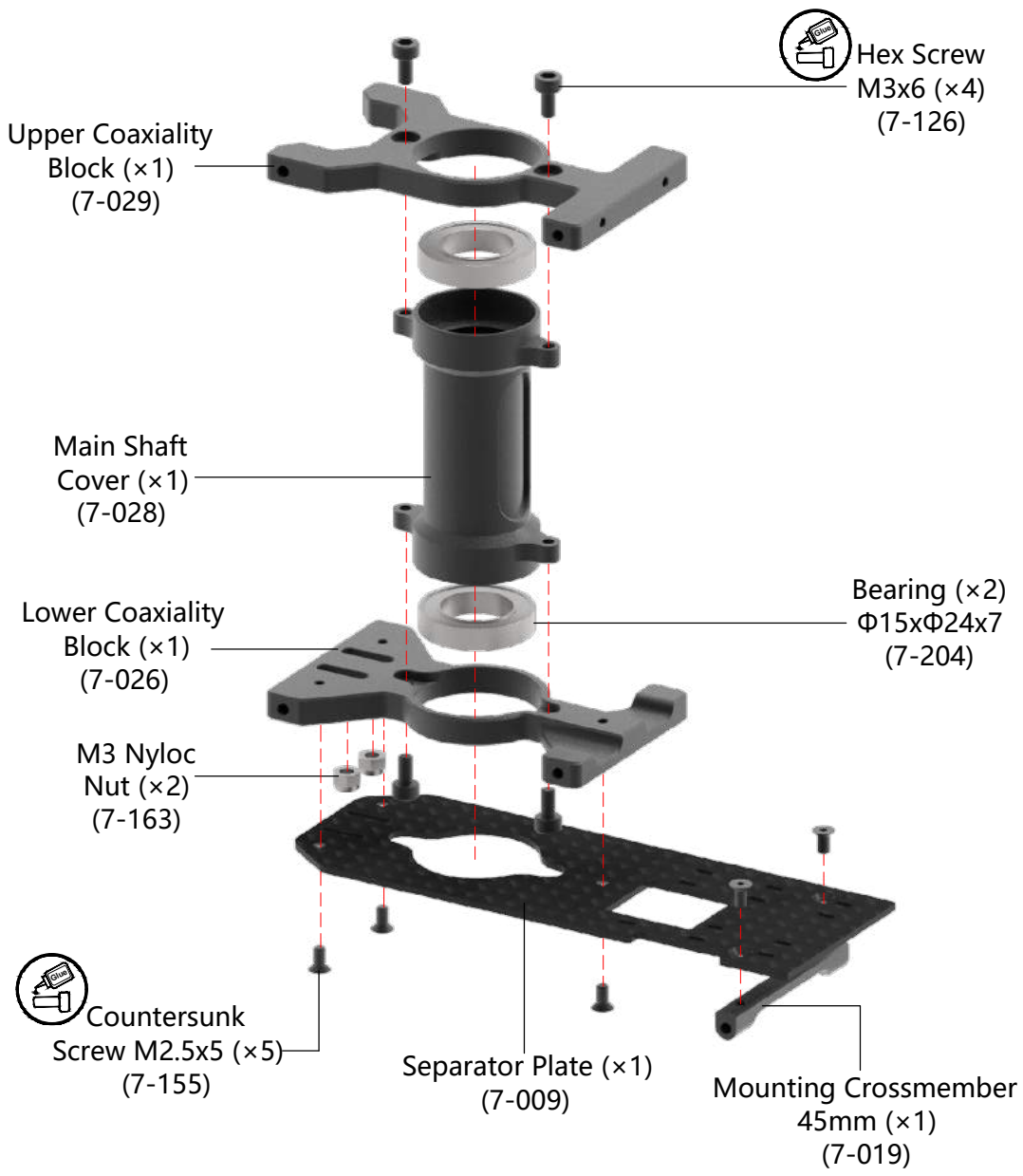

02 Upper Side Panel Assembly

BAG 4

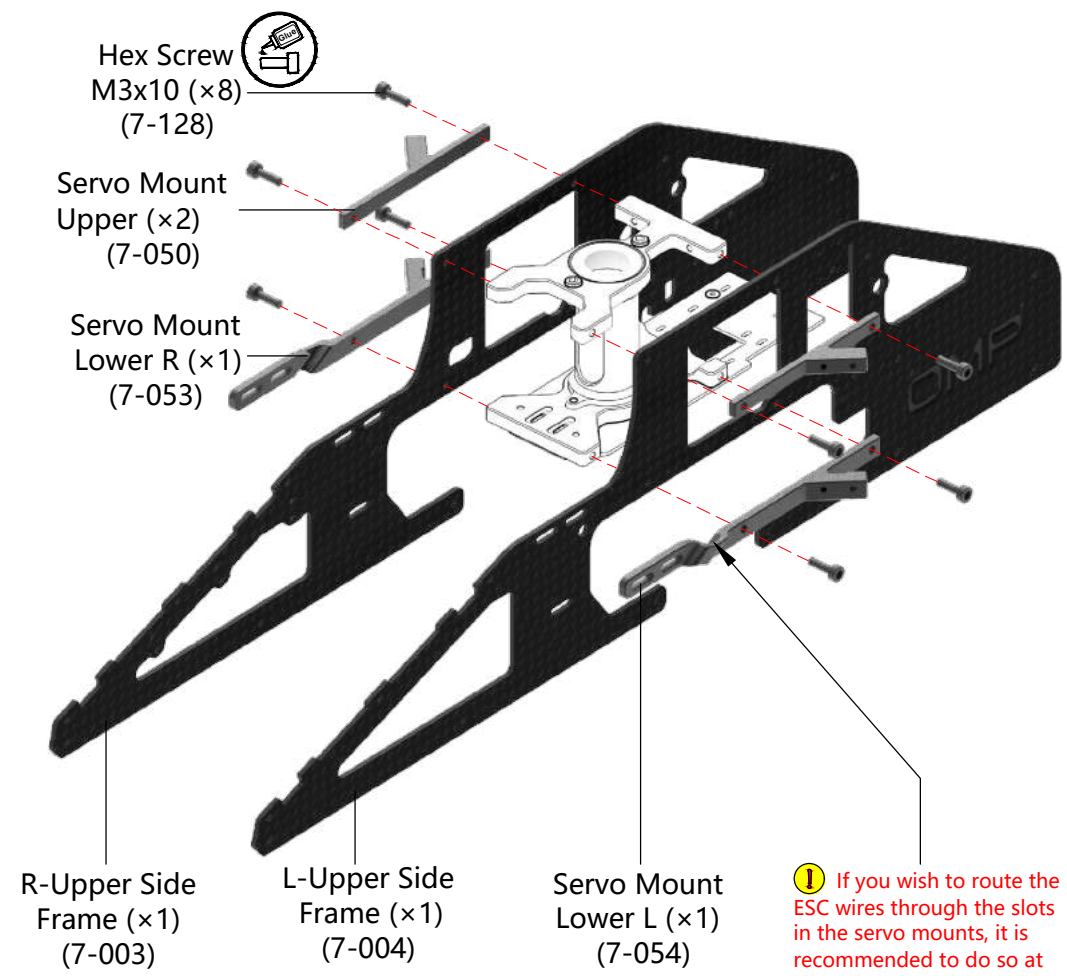

! If you wish to route the ESC wires through the slots in the servo mounts, it is recommended to do so at this step.

BAG 5

01 ESC Plate Assembly

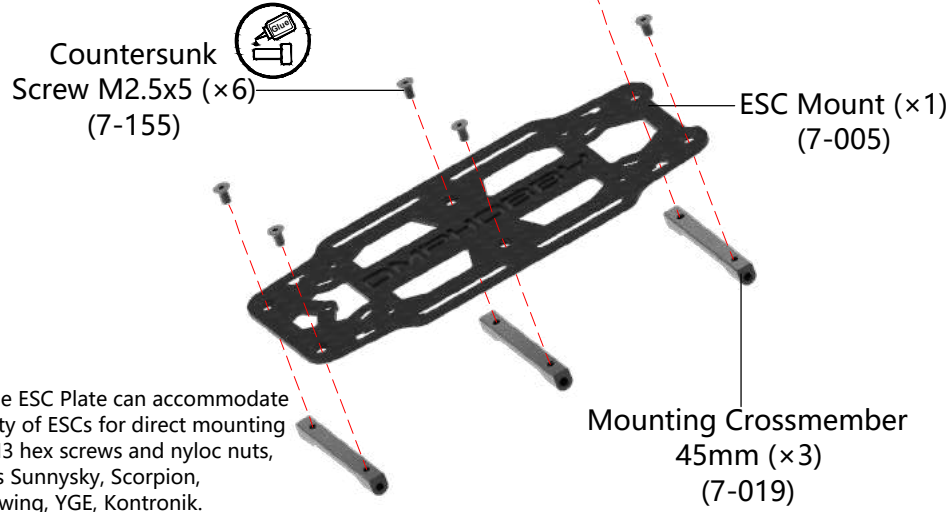

! The ESC Plate can accommodate a variety of ESCs for direct mounting with M3 hex screws and nyloc nuts, such as Sunnysky, Scorpion, Hobbywing, YGE, Kontronik.

02 Installation of the ESC Plate

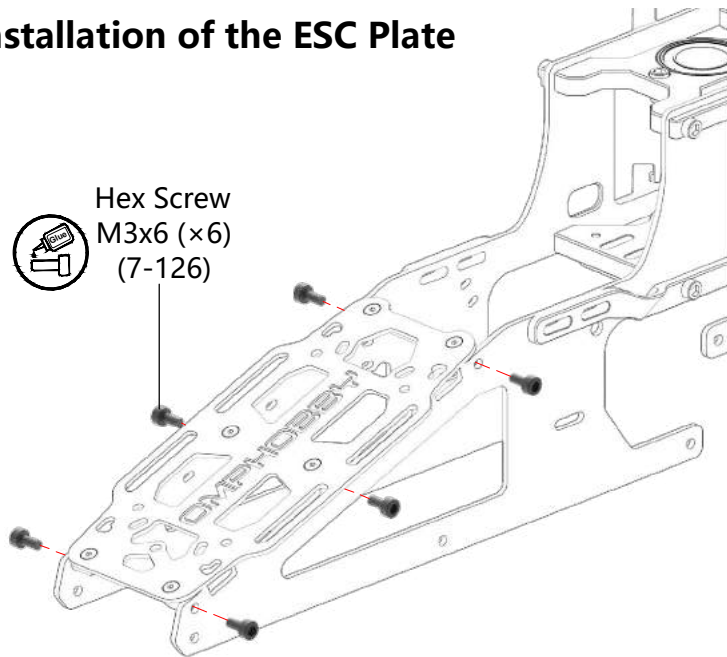

03 Flight Controller Mount and Boom Clamps

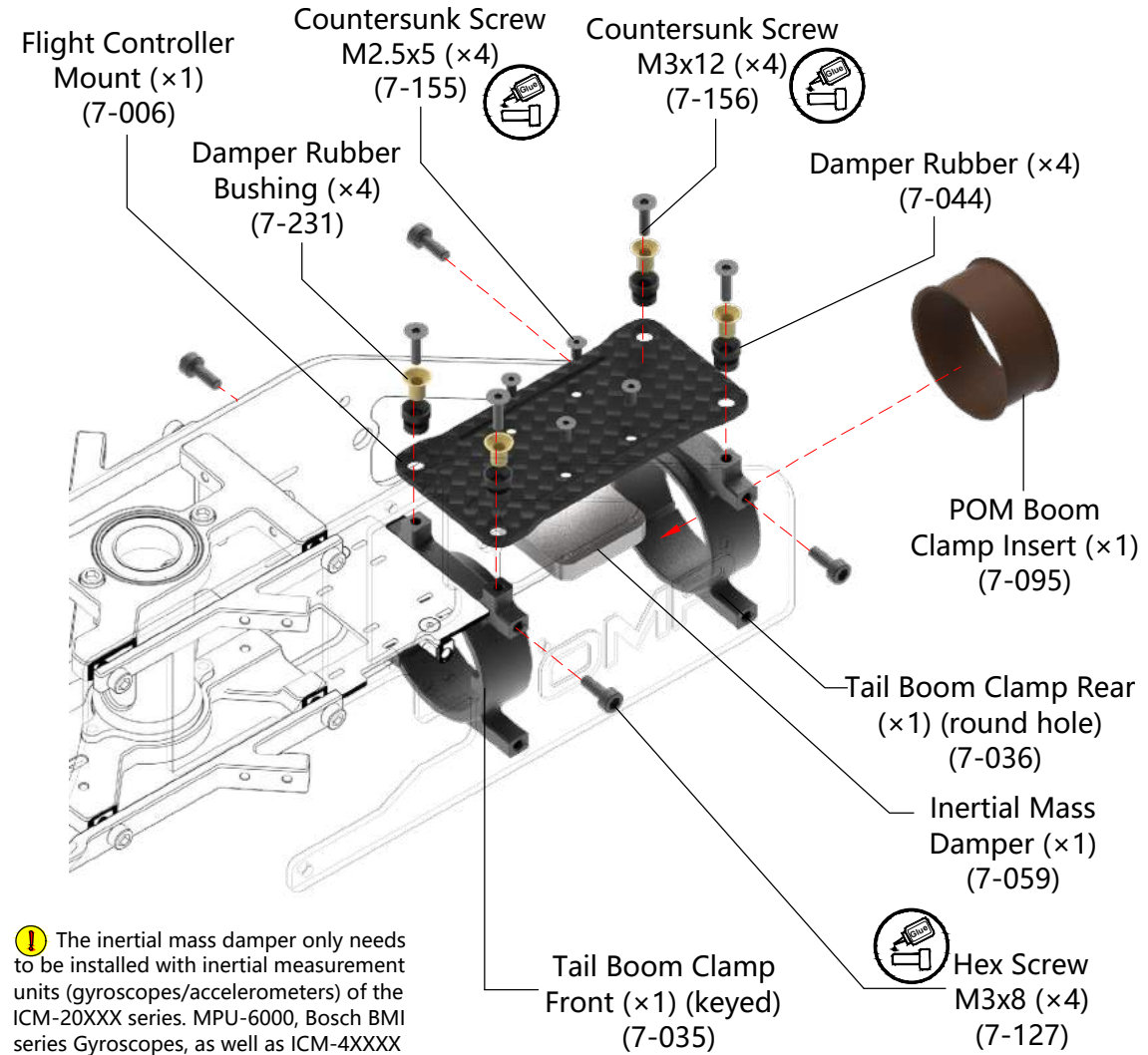

! The inertial mass damper only needs to be installed with inertial measurement units (gyroscopes/accelerometers) of the ICM-20XXX series. MPU-6000, Bosch BMI series Gyroscopes, as well as ICM-4XXXX series IMUs do not require the mass damper to be installed.

01 Canopy Mount Assembly

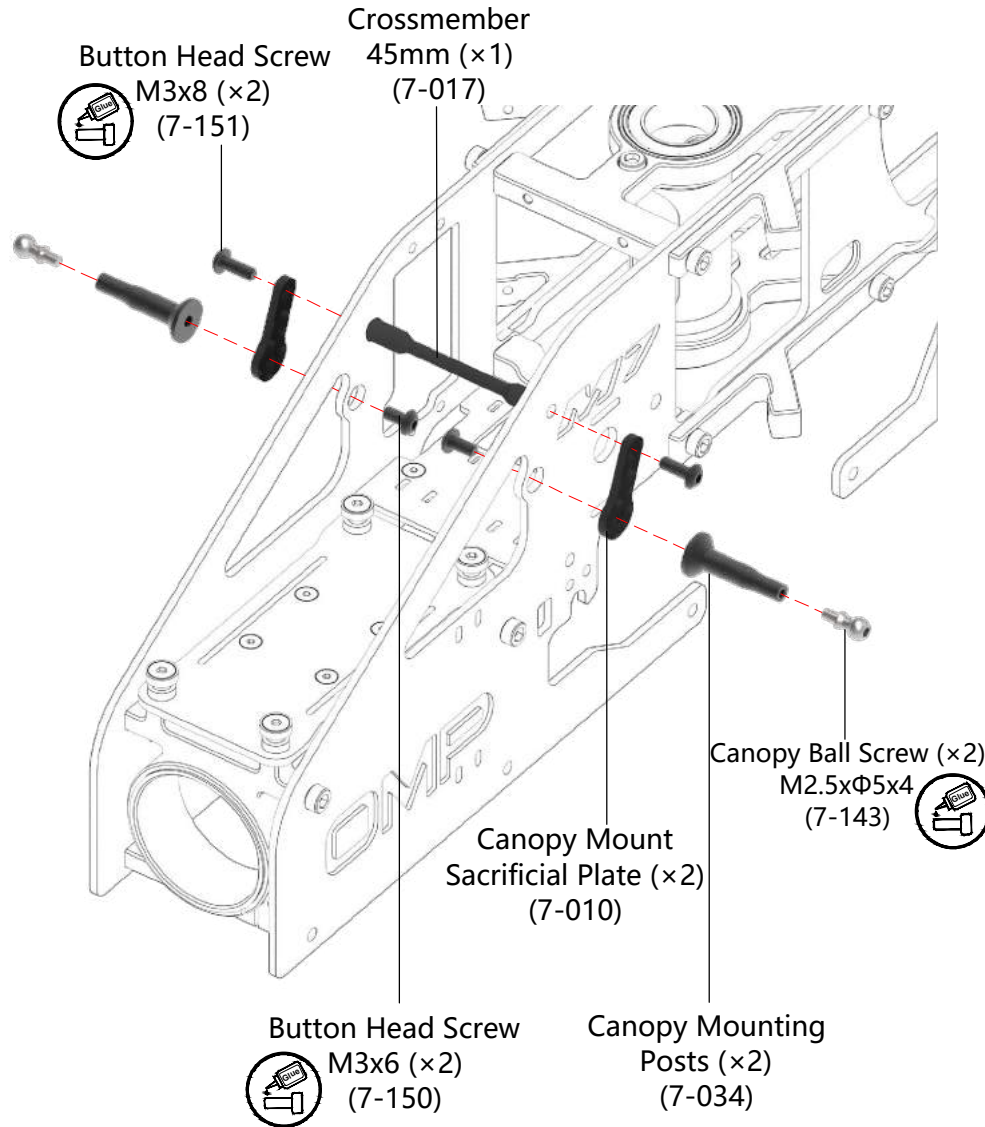

02 Tensioner Idler Pulley Assembly

BAG 6

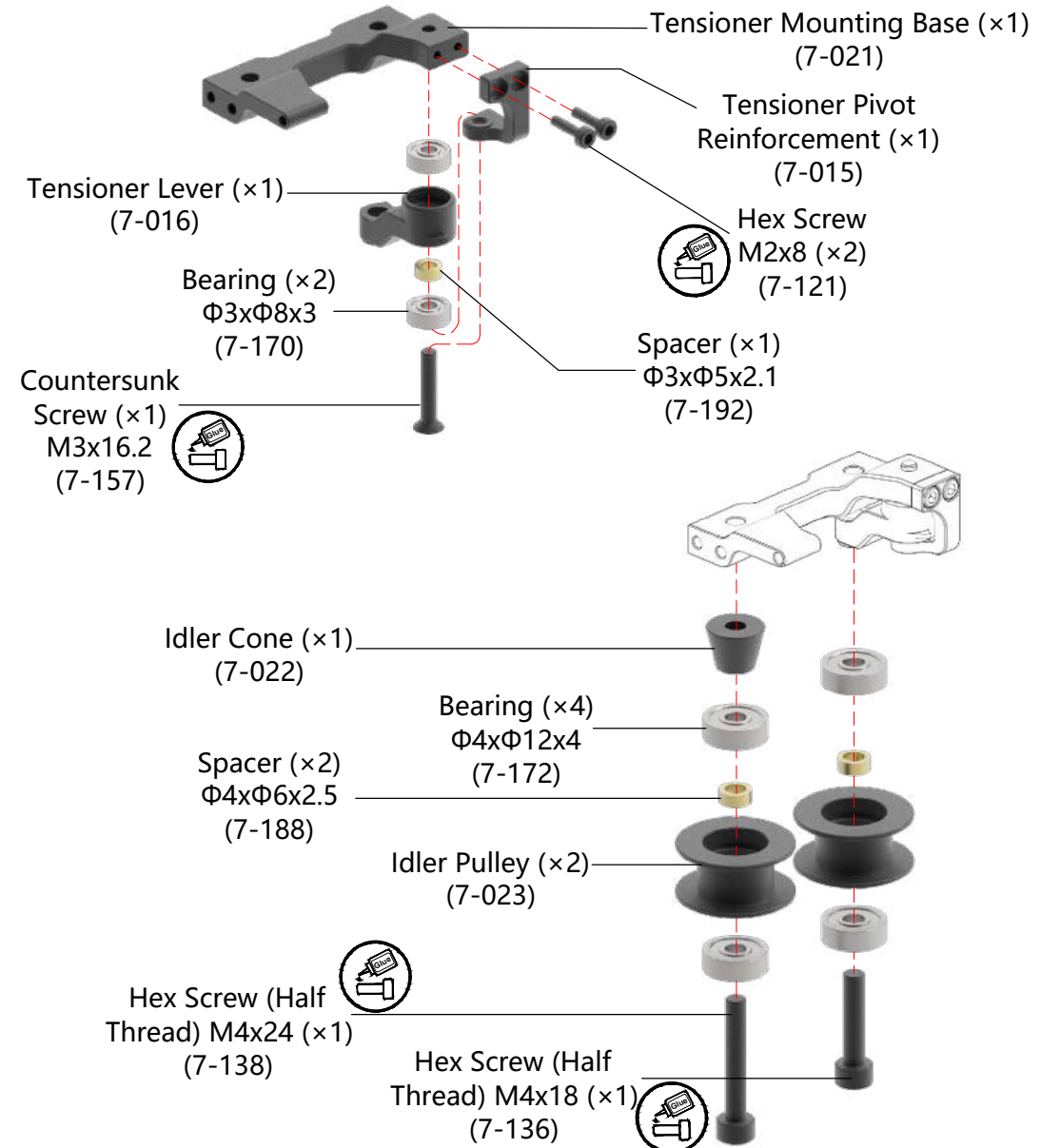

BAG 7

01 Tensioner Assembly

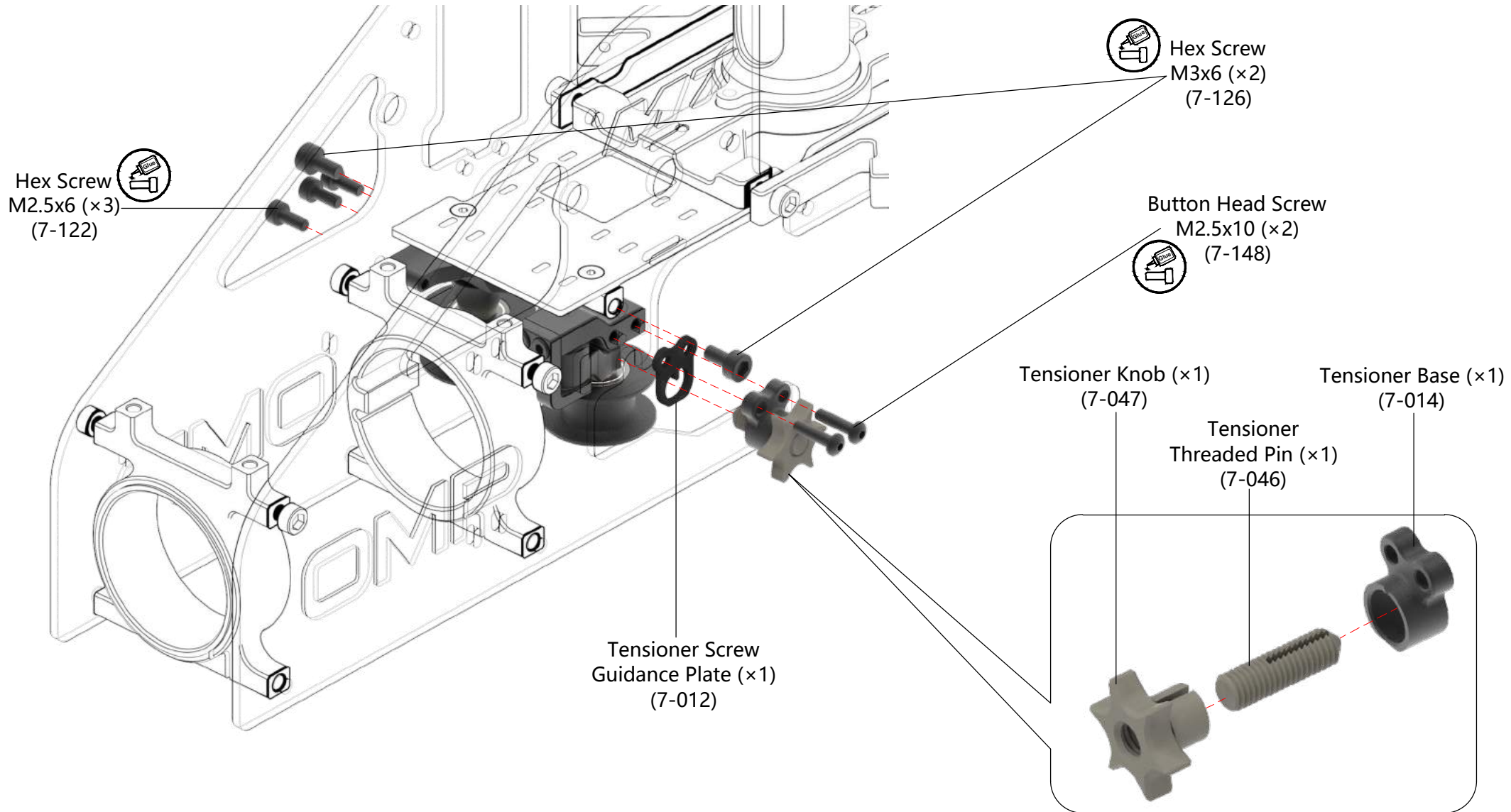

01 Main Pulley Assembly

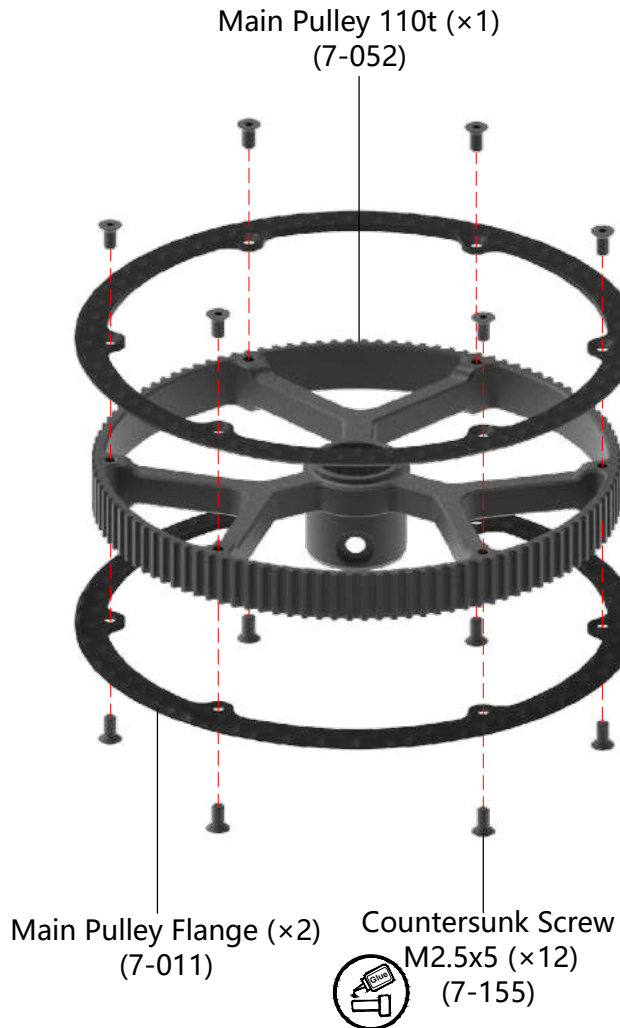

02 Main Gear Assembly

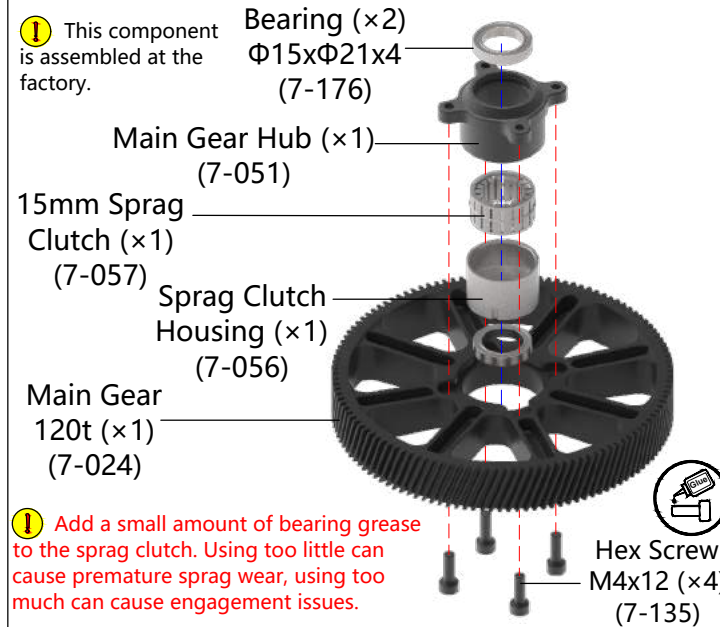

04 Counterbearing Assembly

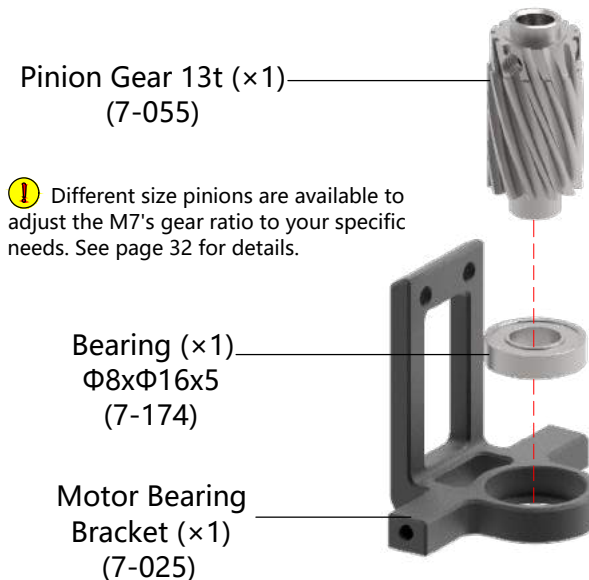

03 Motor Installation

BAG 8

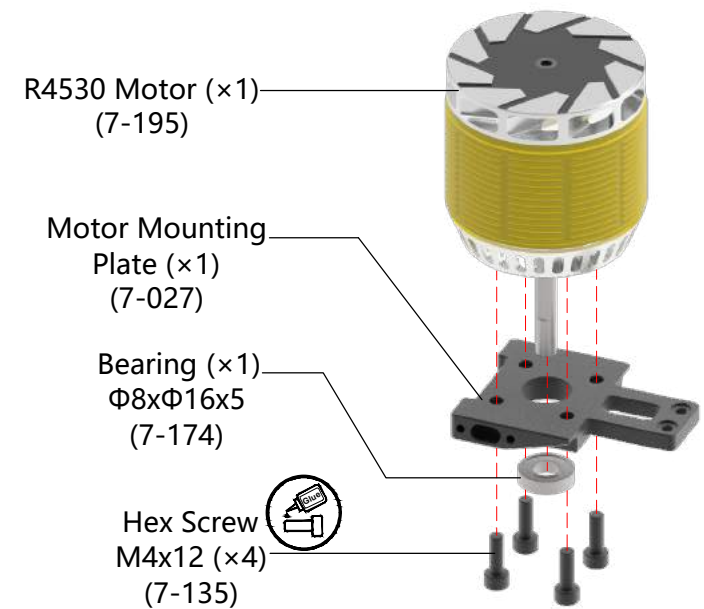

05 Motor Mount Assembly

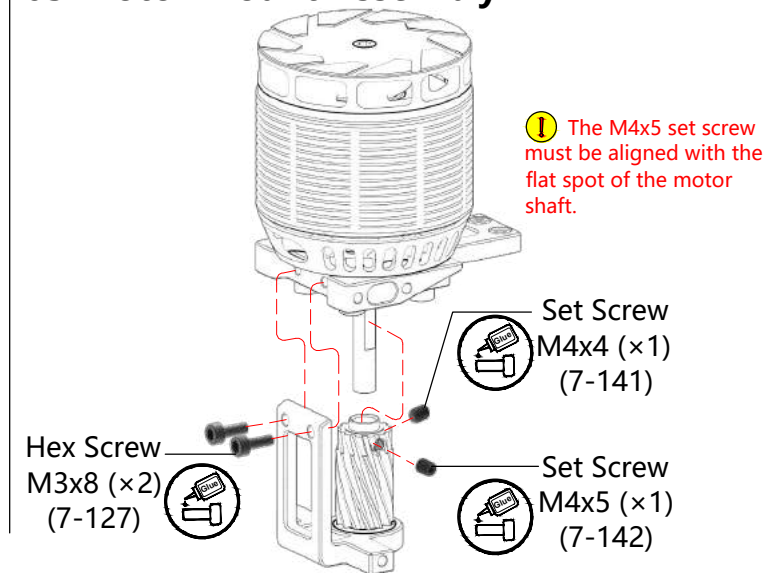

BAG 9

01 Pre-installation of the main drive gear

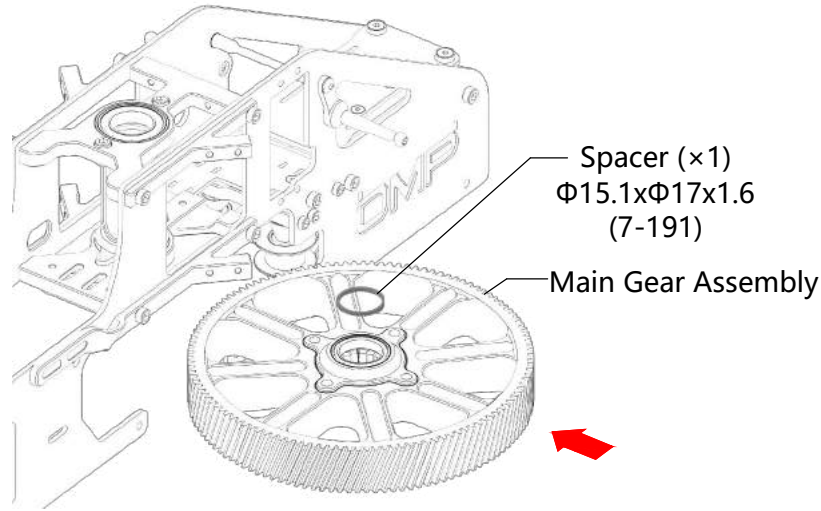

02 Main Rotor Shaft Installation

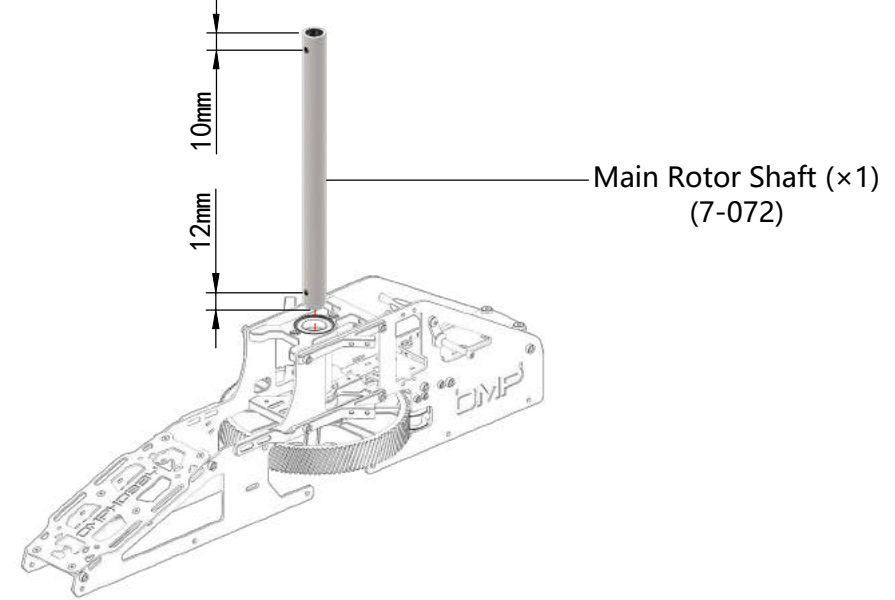

03 Main Pulley Installation

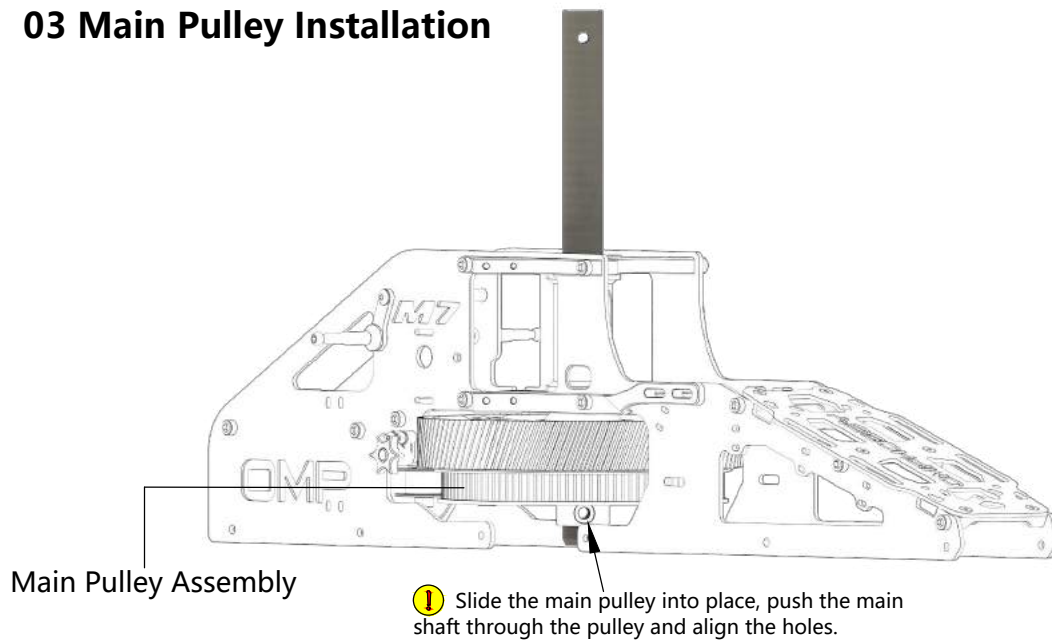

04 Lower Main Shaft Bolt Installation

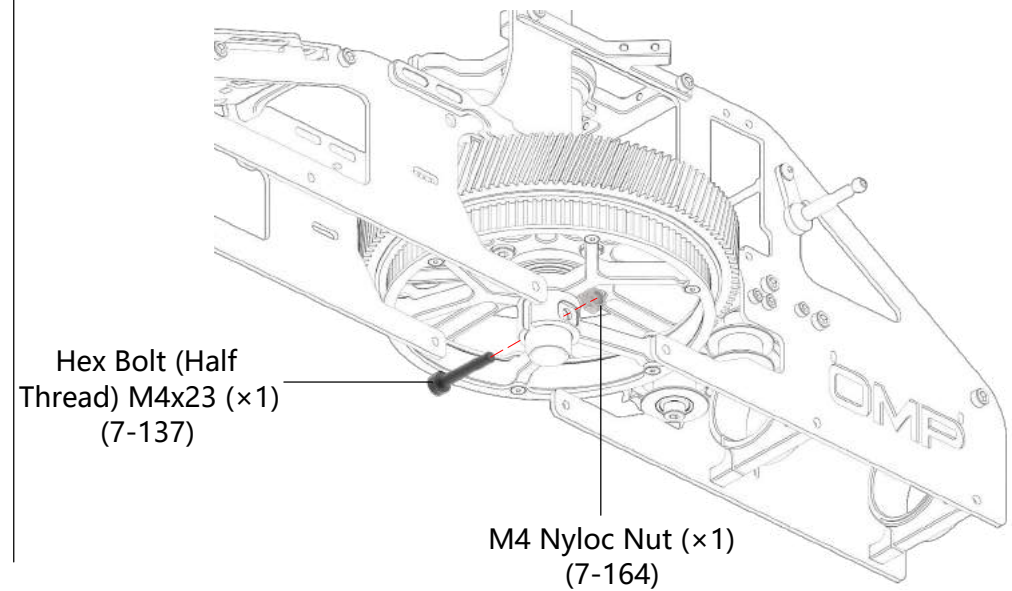

01 Tail Rotor Hub Assembly

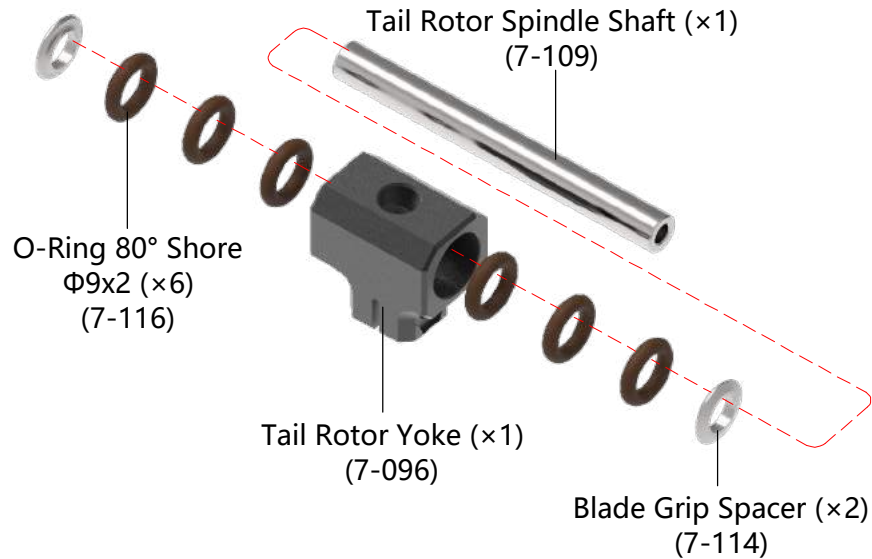

02 Tail Rotor Blade Grip Assembly

BAG 10

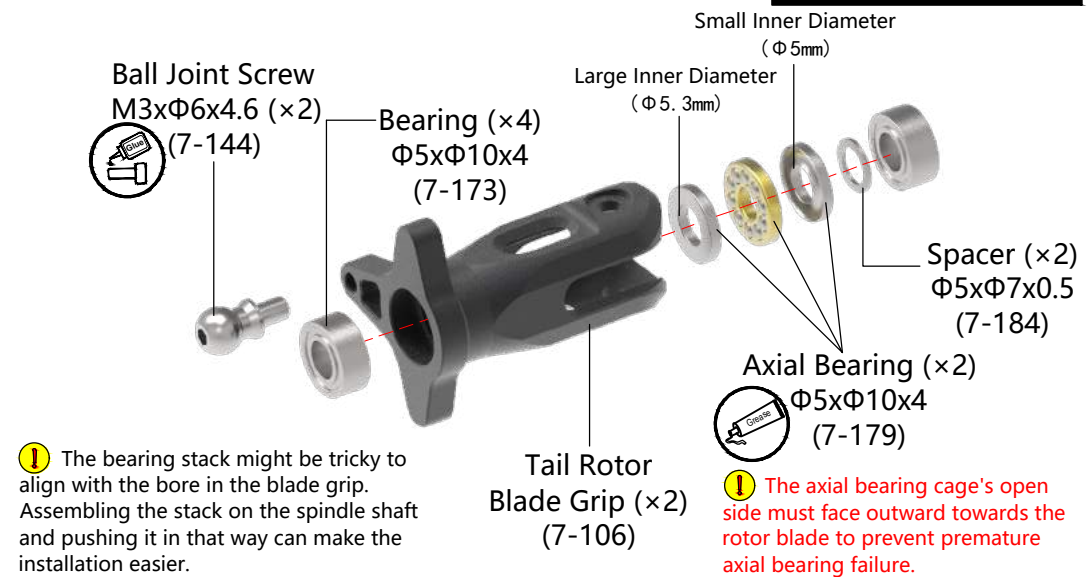

03 Tail Rotor Head Assembly

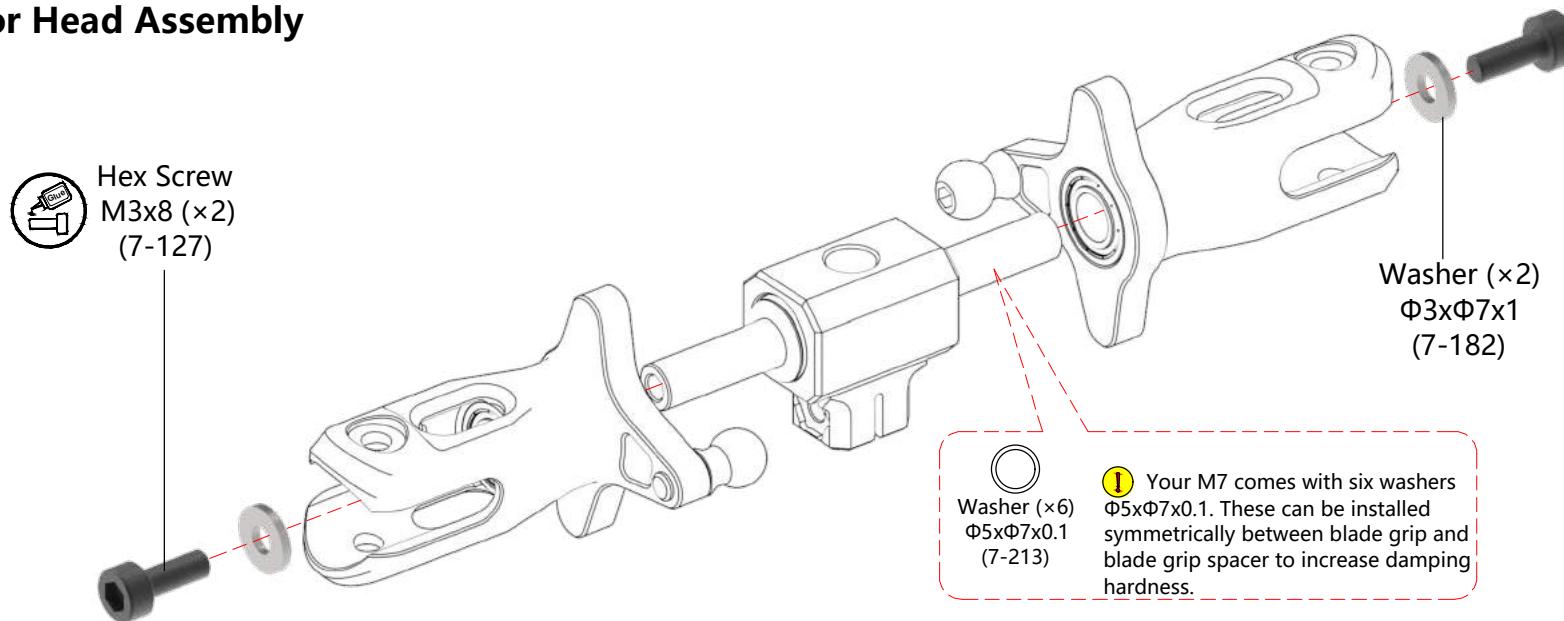

BAG 11

01 Tail Belt Pressure Idler Assembly

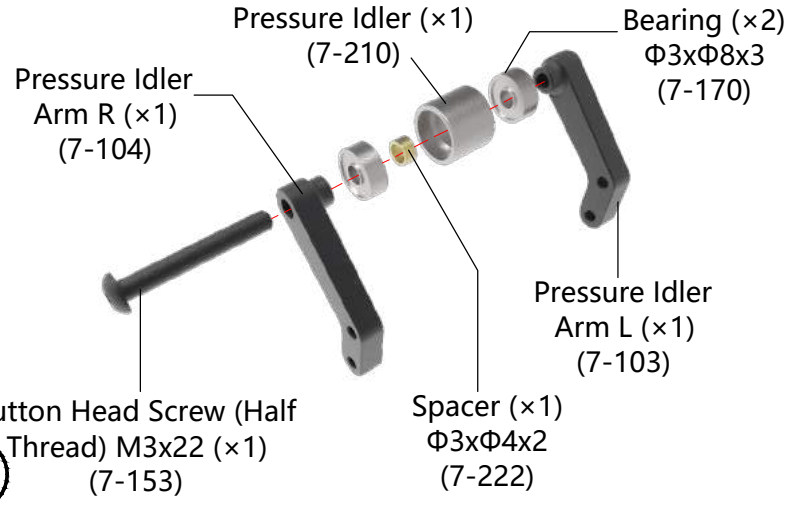

02 Tail Pitch Slider Bridge Assembly

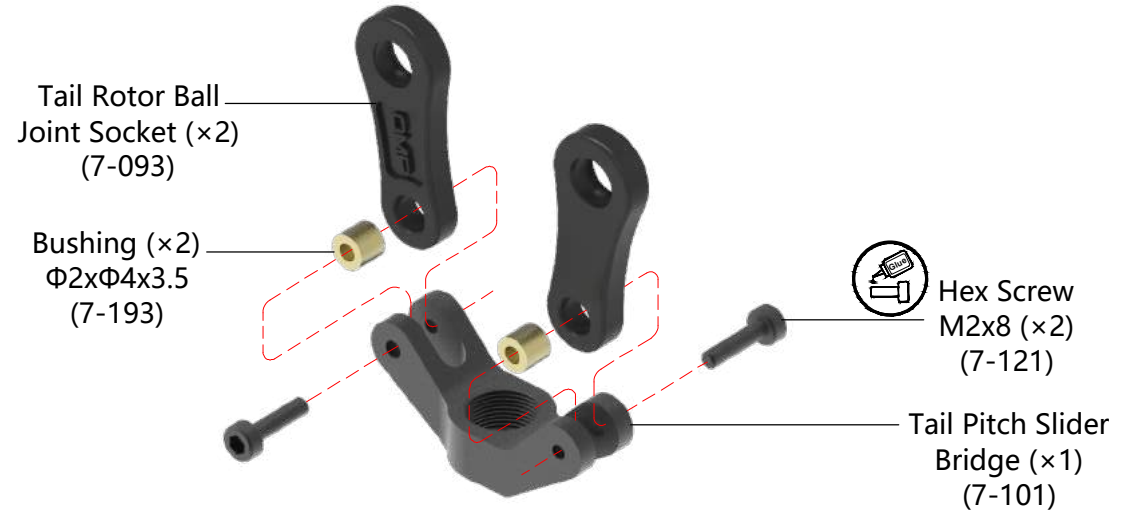

03 Tail Pitch Slider Ring Assembly

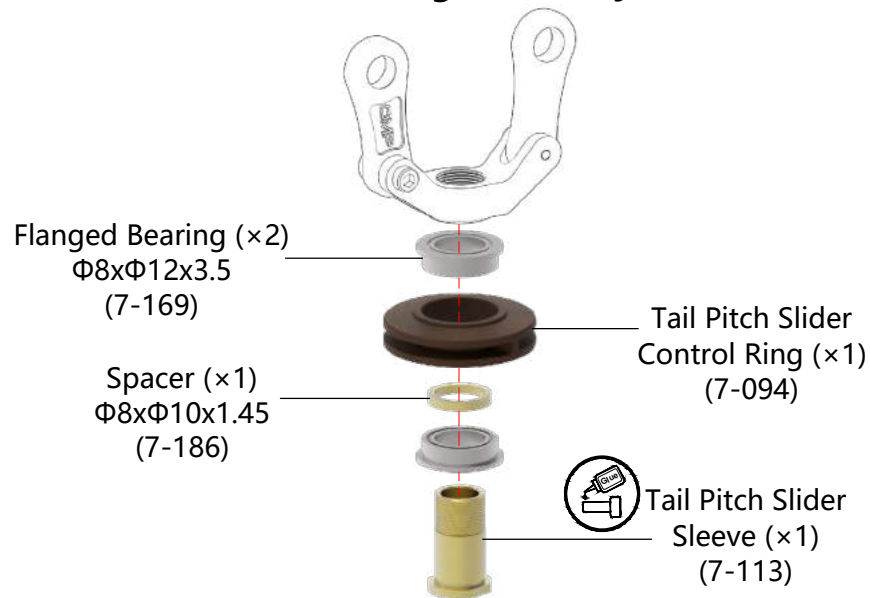

04 Tail Bellcrank Assembly

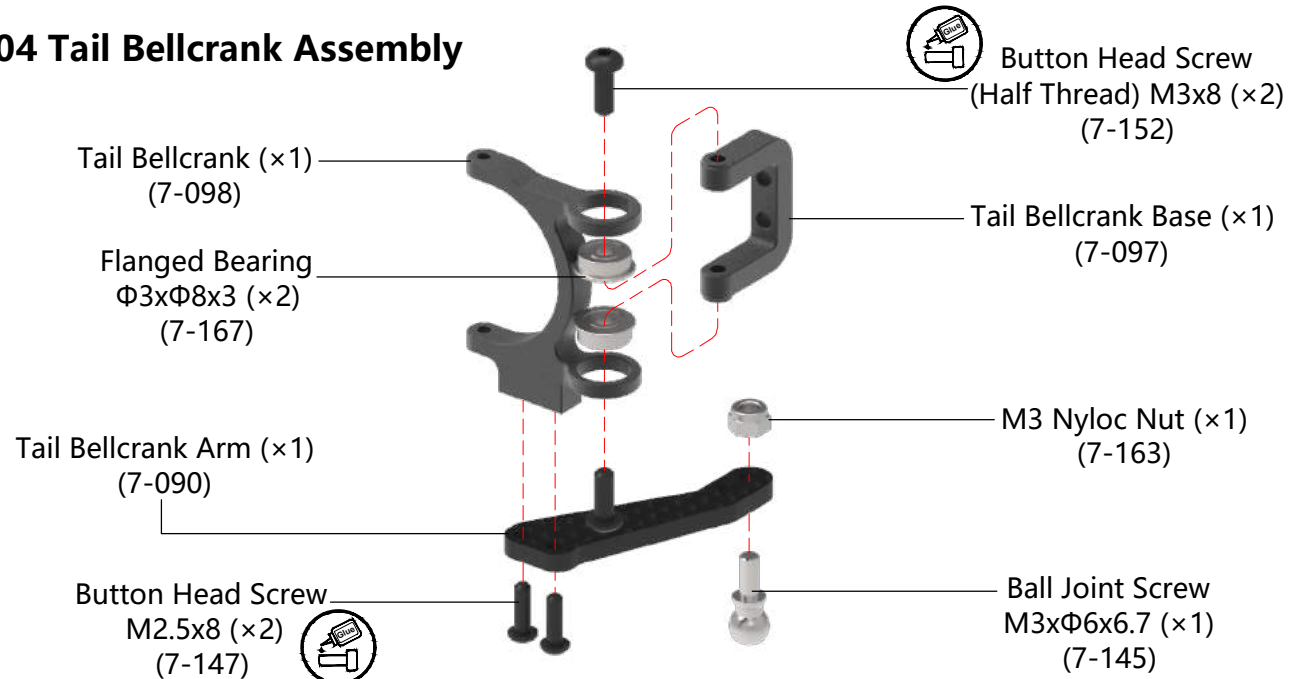

01 Tail Gearbox Assembly

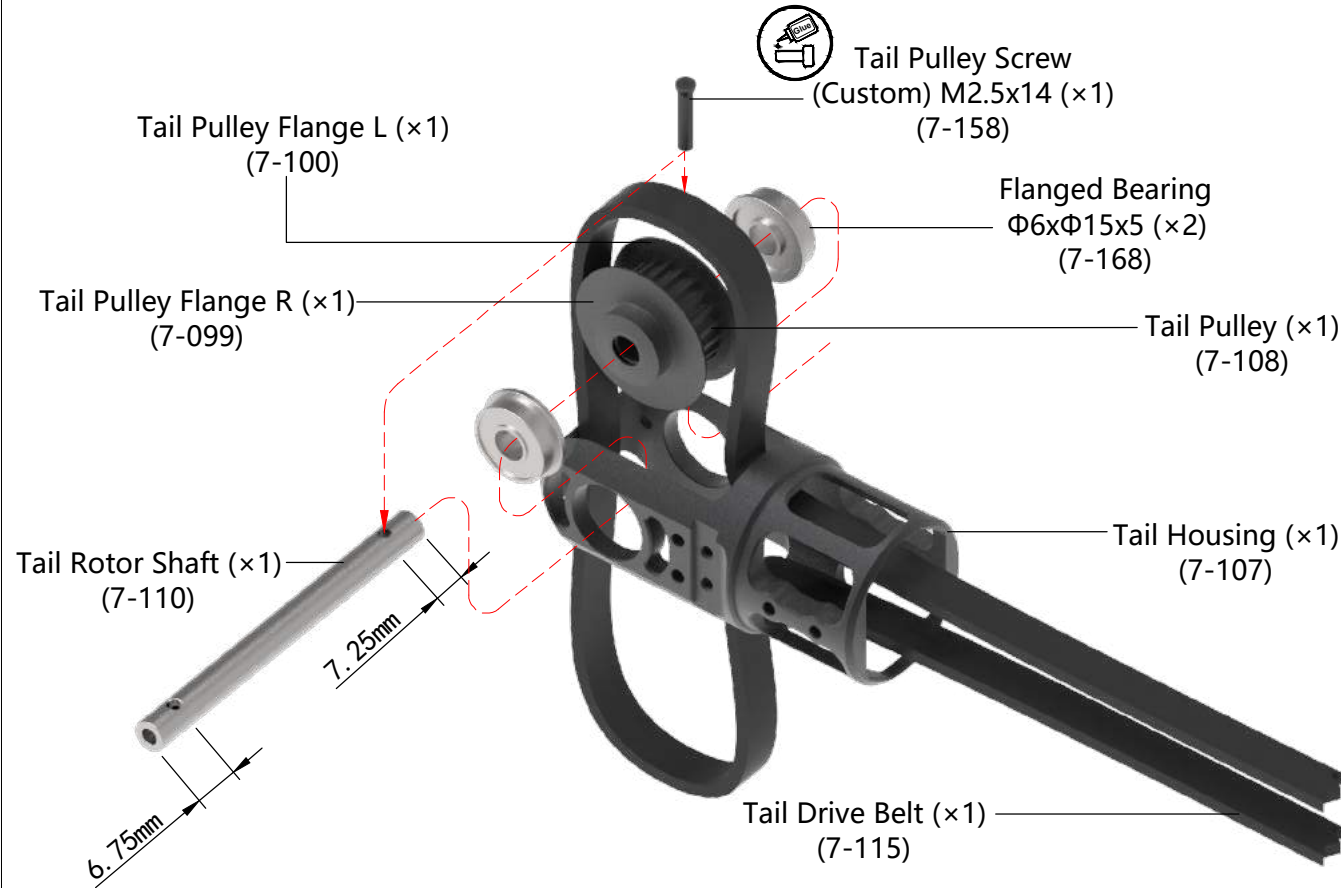

02 Tail Gearbox Installation

BAG 12

⚠ Your M7 comes with two tail boom options: Carbon Fiber and painted Aluminium. Feel free to choose whichever you like best!

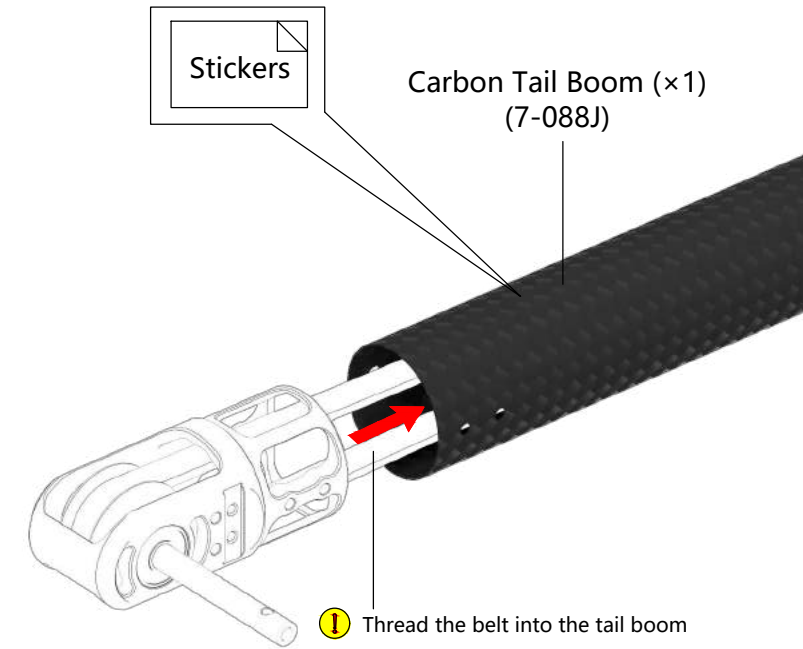

⚠ Please refer to page 33 for the sticker placement.

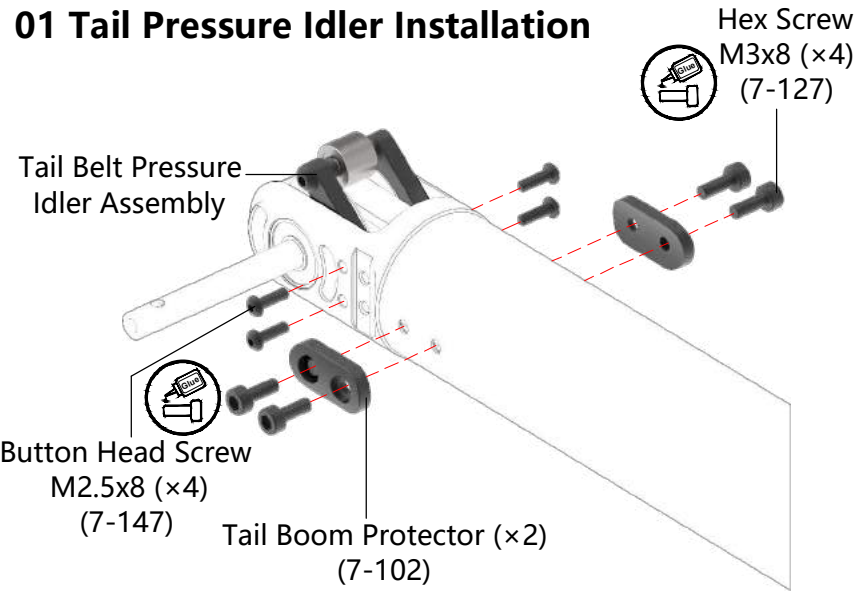
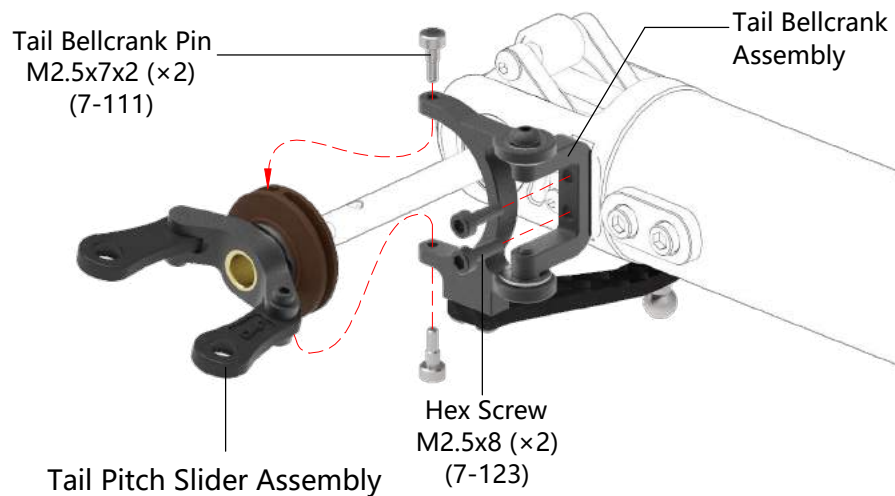
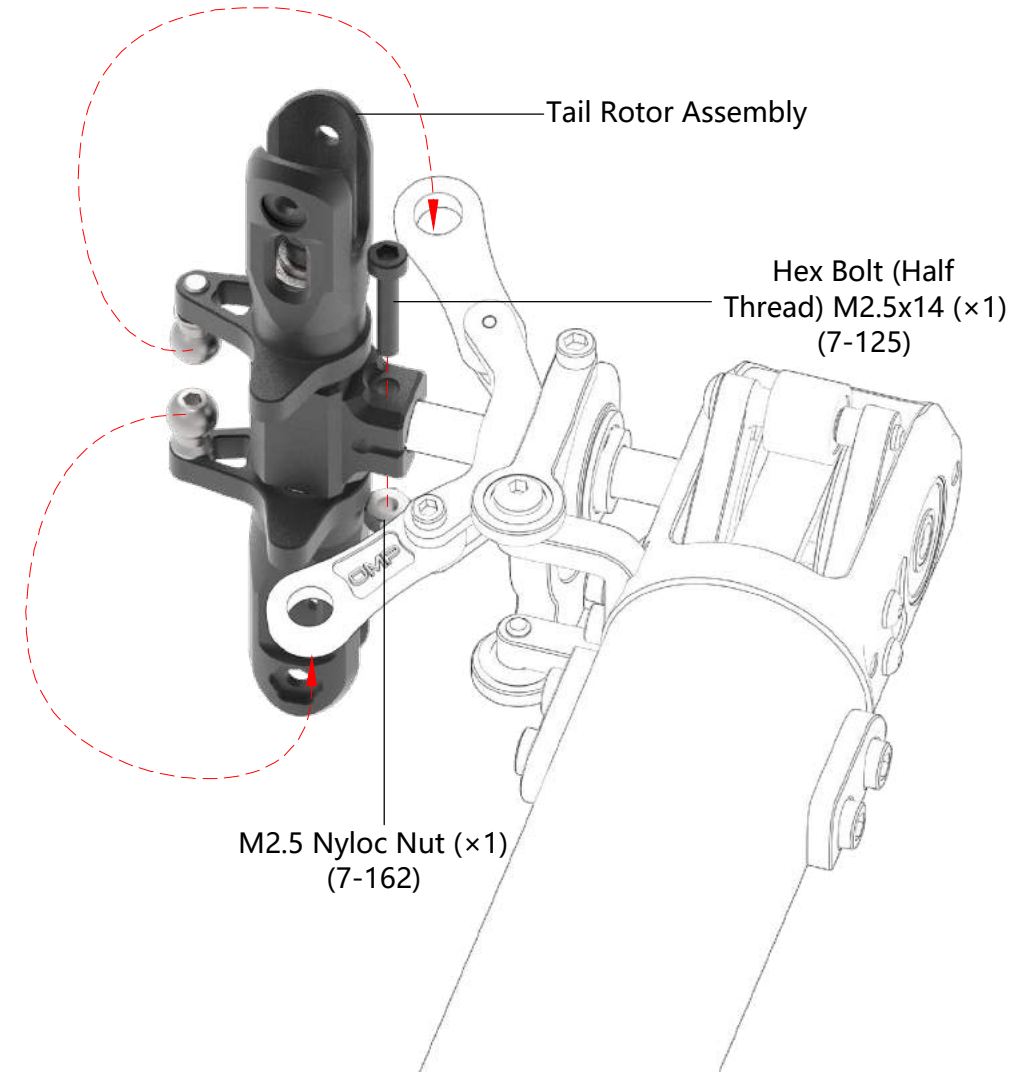
BAG 13**01 Tail Pressure Idler Installation****02 Tail Pitch Slider Installation****03 Tail Rotor Installation**

01 Attach the tail boom assembly to the frame

⚠ Pay close attention when installing the belt. Ensure that both sides of the belt are running parallel. The belt must not be twisted in itself. Rotate the free end of the belt 90° as depicted by the arrow in the picture. Once you have achieved the state shown in the picture, insert the belt into the frame and loop it around the main belt pulley.

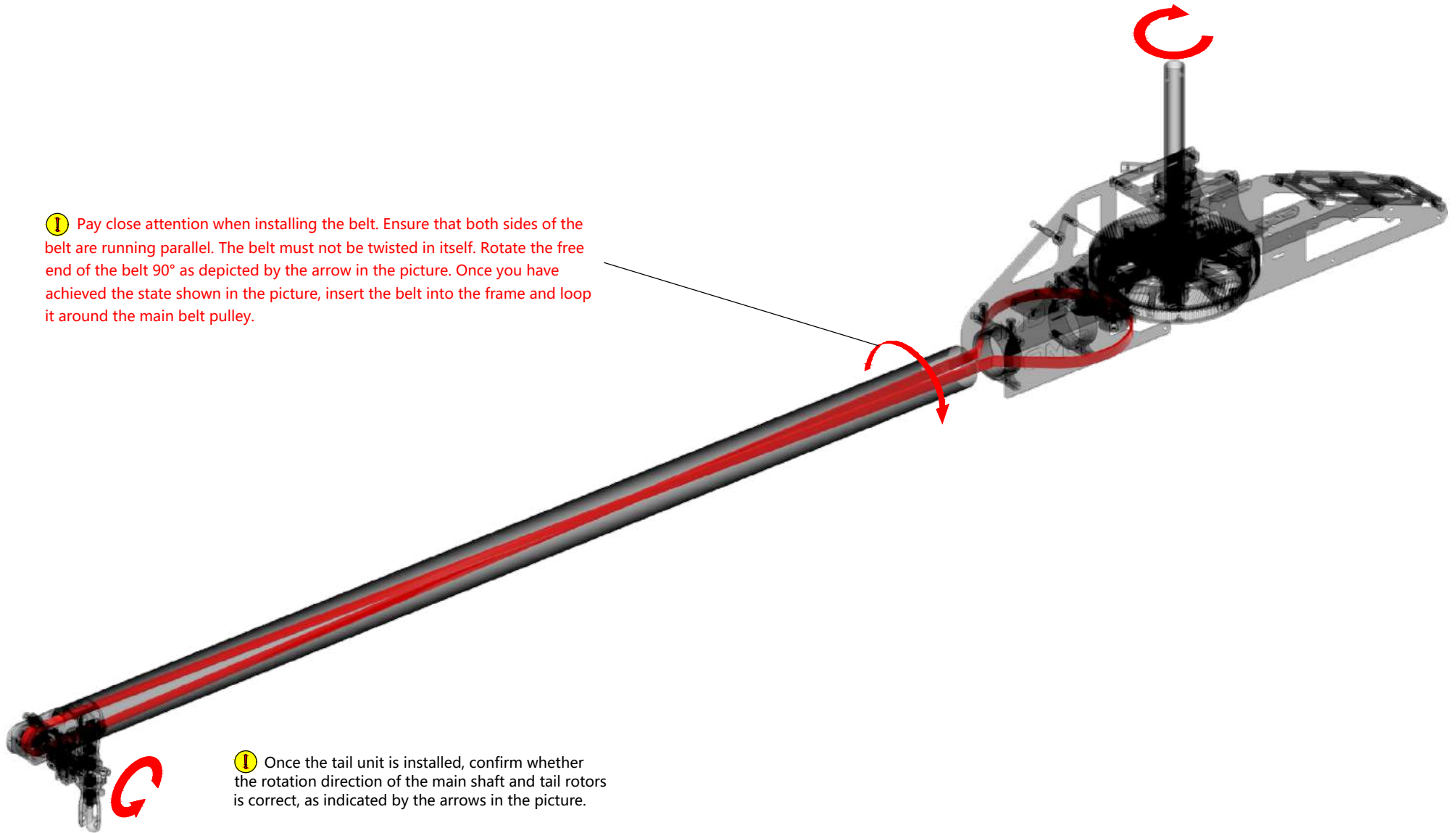

⚠ Once the tail unit is installed, confirm whether the rotation direction of the main shaft and tail rotors is correct, as indicated by the arrows in the picture.

BAG 15

01 Main Rotor Shaft Clamp Installation

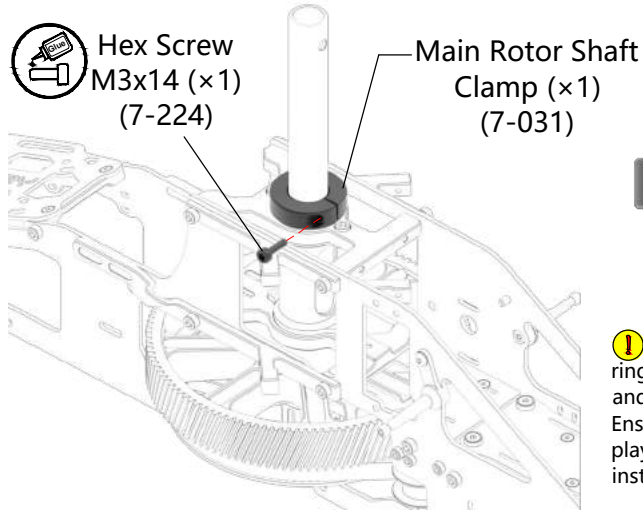

⚠ The flange of the clamp ring should face downwards and contact the bearing. Ensure there is no vertical play in the main shaft after installation.

02 Servo Assembly

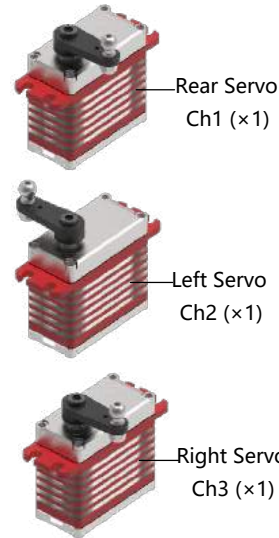

⚠ After finding the neutral position with the help of your flight controller, assemble three servos with two different arm orientations. The angle of the arm relative to the servo body should be 90°.

OMP Plastic Servo Arm (x4) (7-049J)

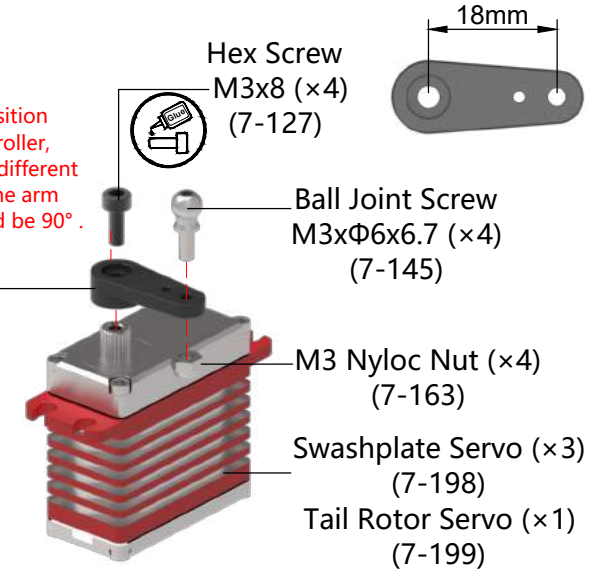

⚠ If using OMP plastic servo arms, please use M3xΦ6x6.7 ball joint screws with nyloc nuts.
If you are using metal servo arms, please use M3xΦ6x4.6 ball joint screws without nyloc nuts.

03 Front Servo Installation

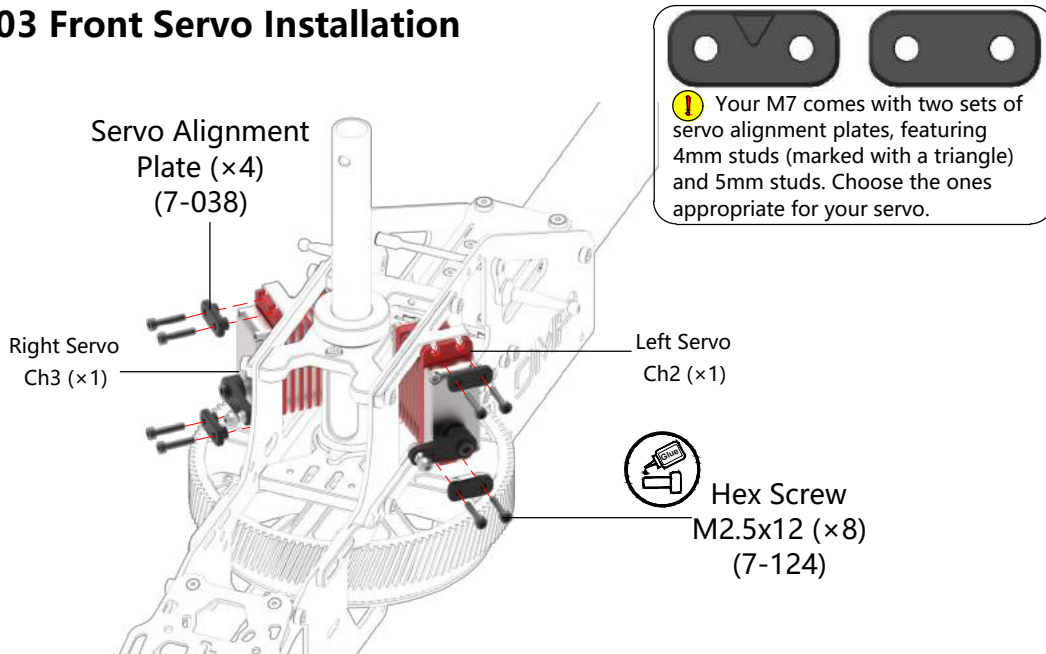

04 Rear Servo Installation

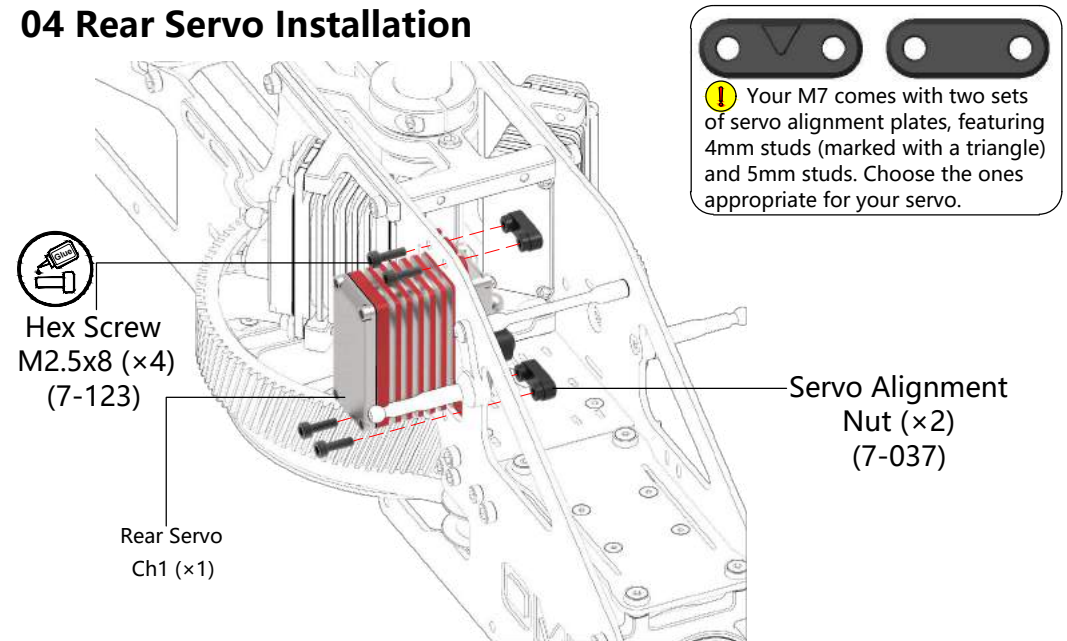

01 Lower Aux Plate Assembly

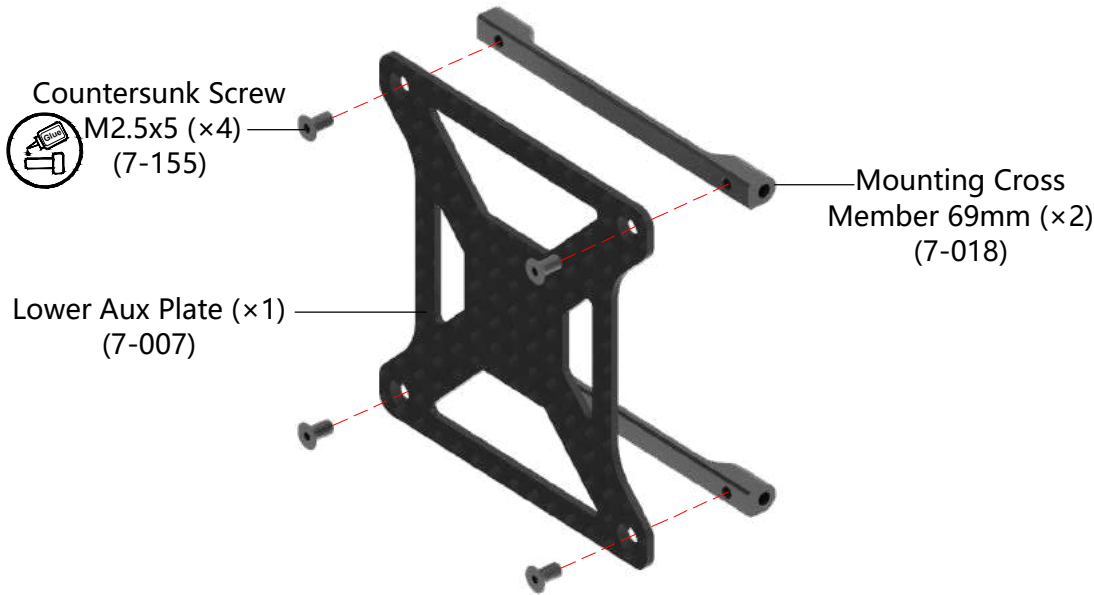

02 Upper Aux Plate Assembly

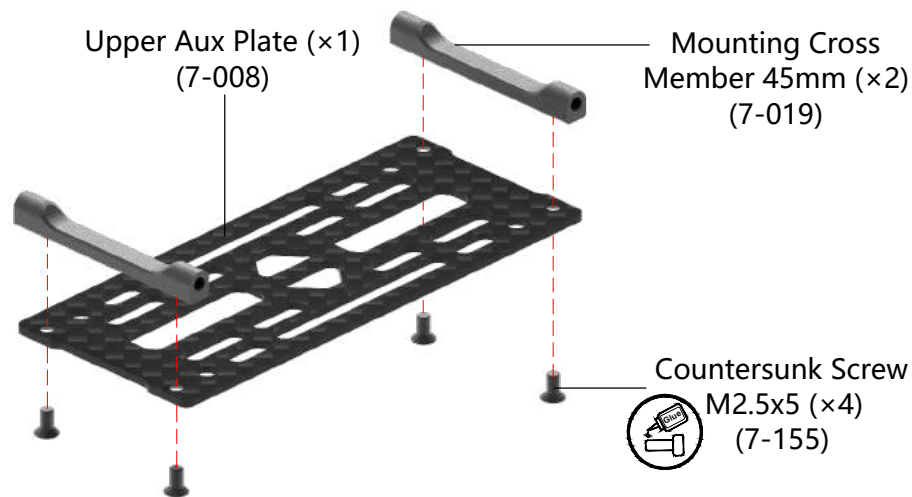

03 Battery Quick Release Assembly

BAG 16

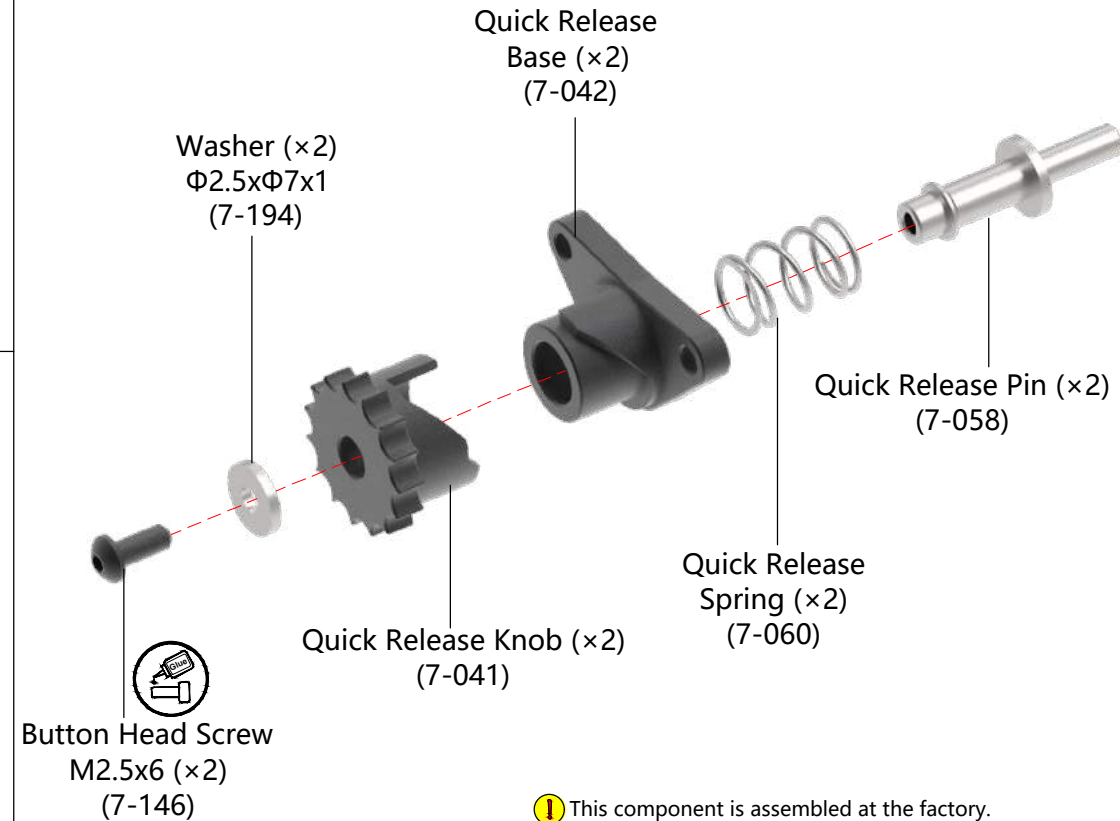

BAG 17

01 Lower Carbon Panel Installation

⚠ These screws are used to clamp the tail boom. Install them loosely in this step, then tighten them in the next step.

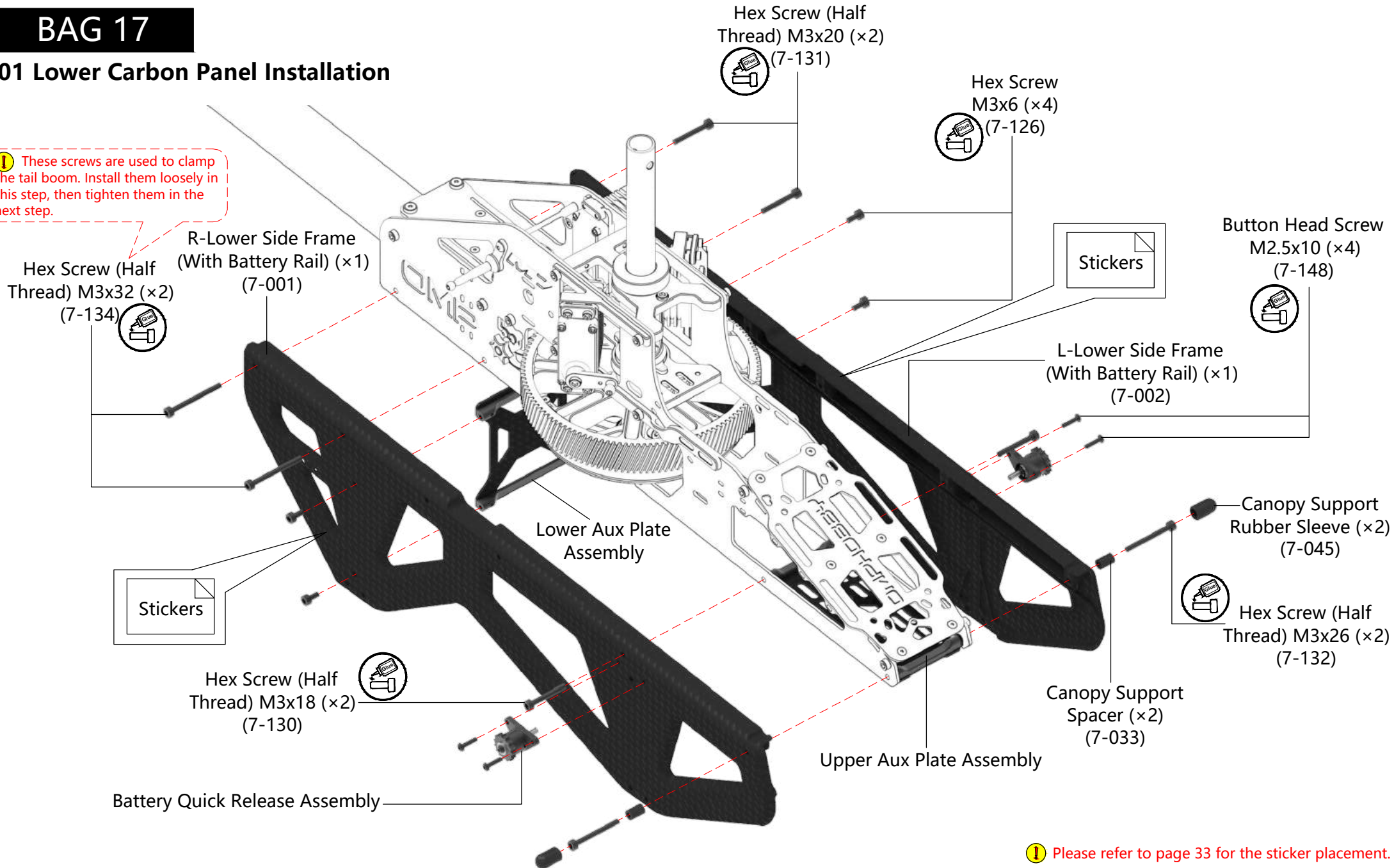

⚠ Please refer to page 33 for the sticker placement.

Step 1

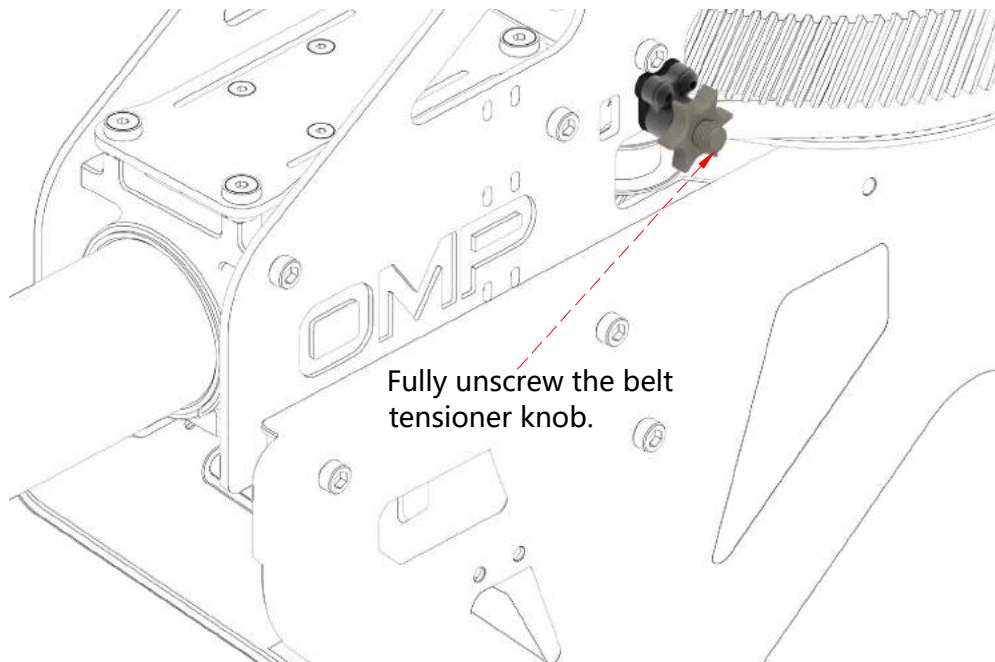

Fully unscrew the belt tensioner knob.

Step 2

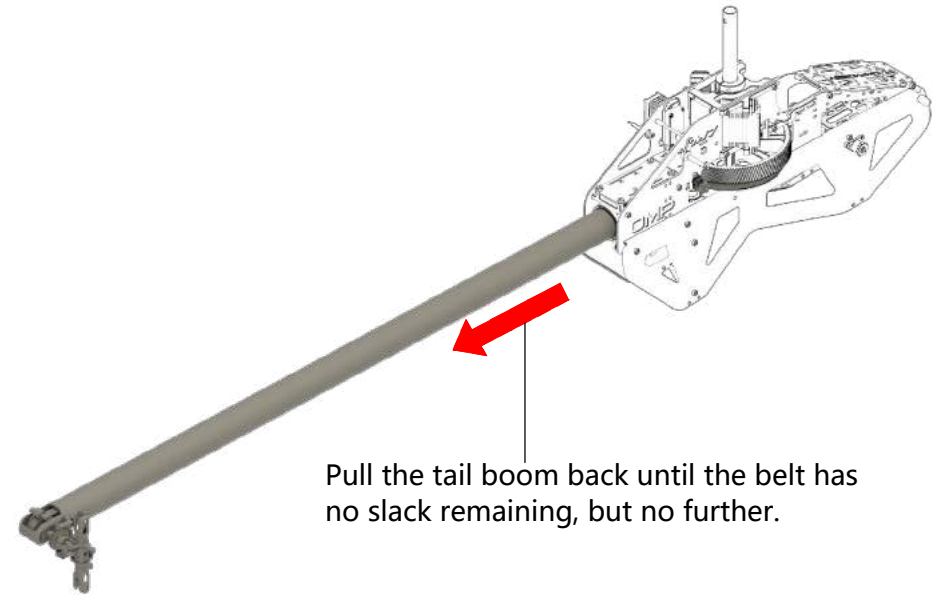

Pull the tail boom back until the belt has no slack remaining, but no further.

Step 3

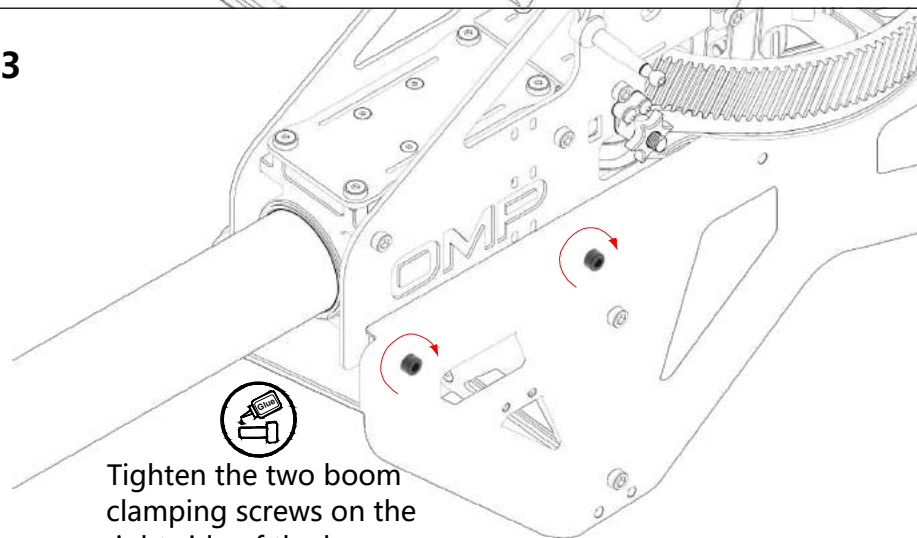

Tighten the two boom clamping screws on the right side of the lower frame.

Step 4

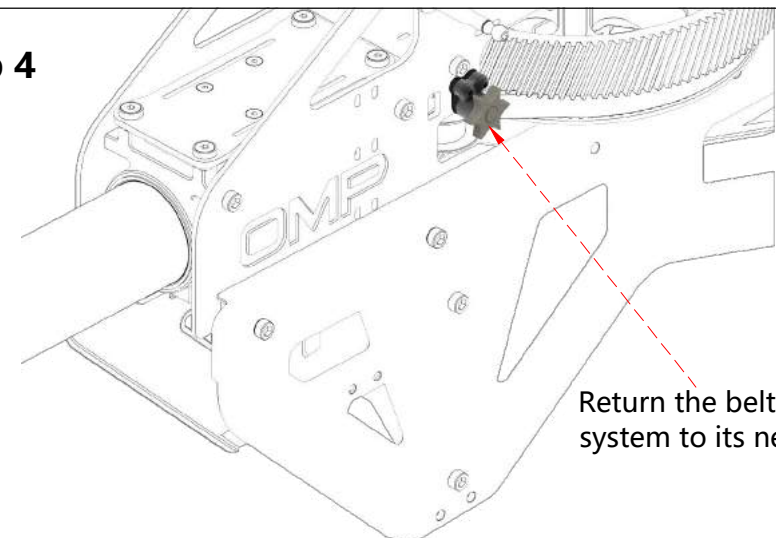

Return the belt tensioner system to its neutral position.

⚠ Confirm good tension of the belt!

BAG 19

01 3rd Main Shaft Bearing Block

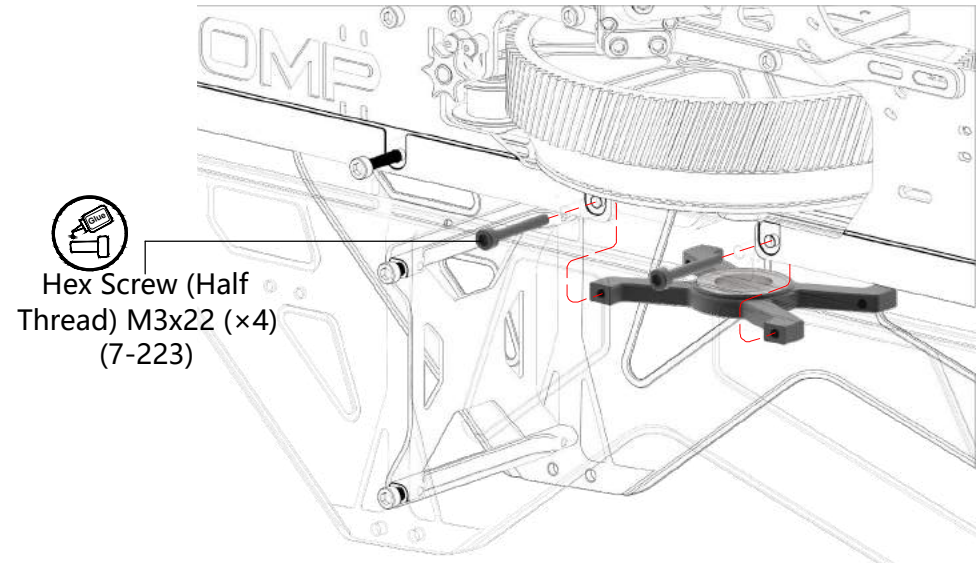
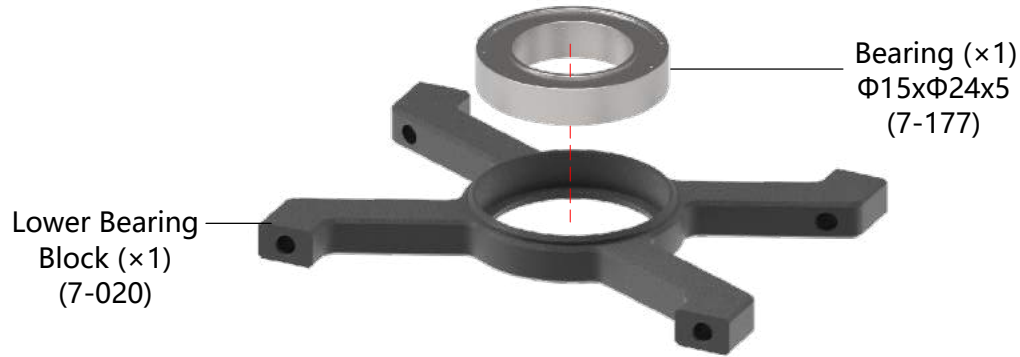

02 Tail Rotor Servo Installation

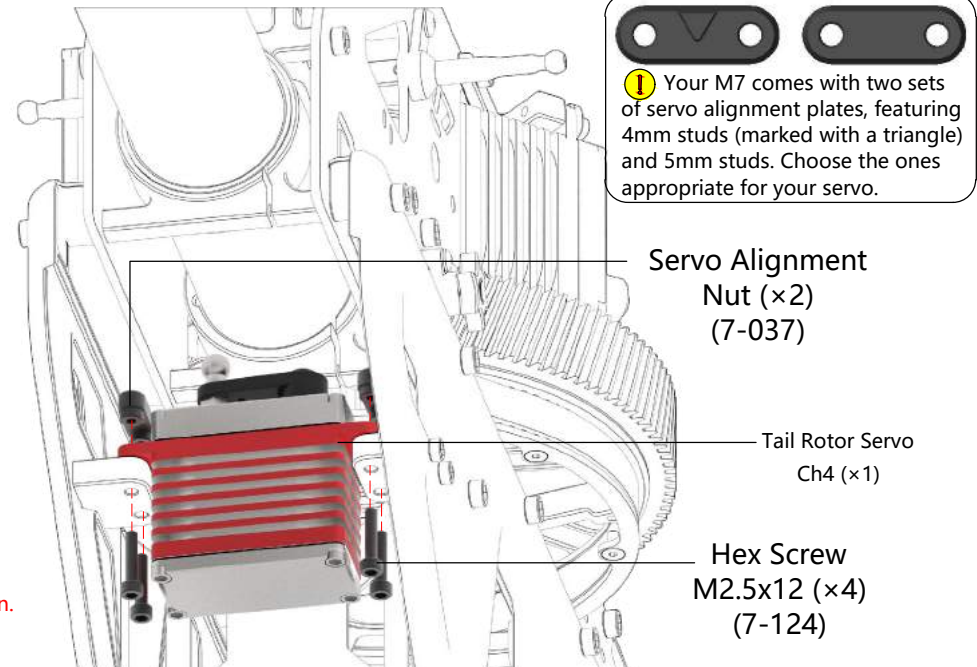
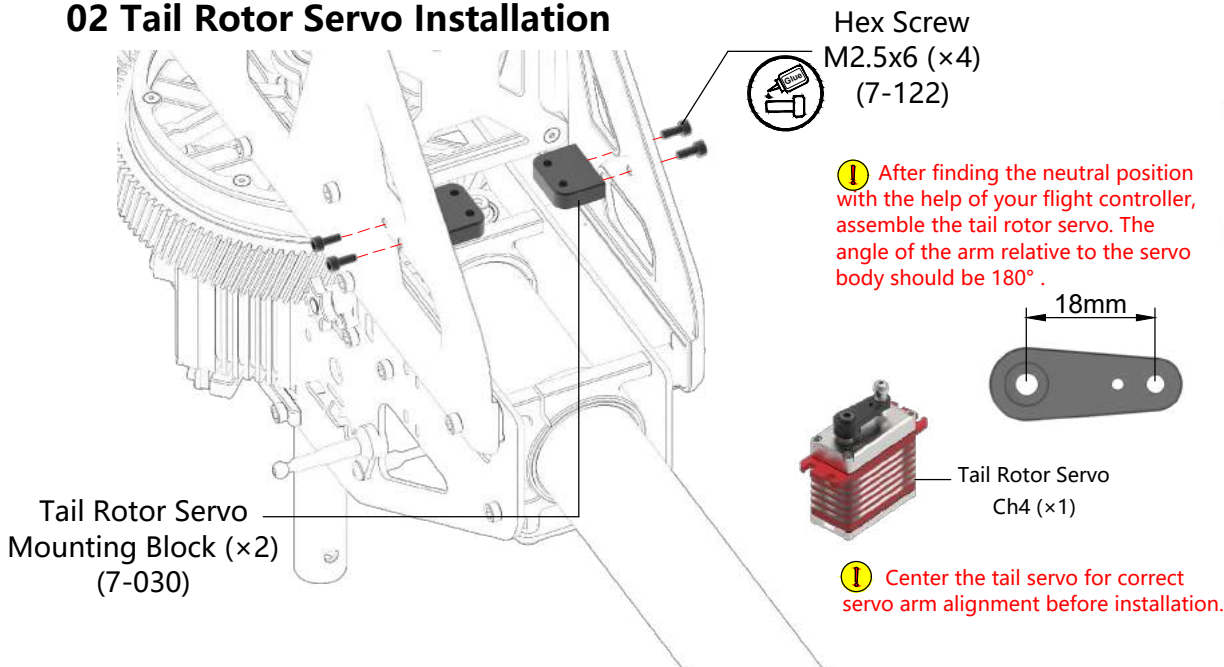

01 Installation of the Landing Gear

BAG 20

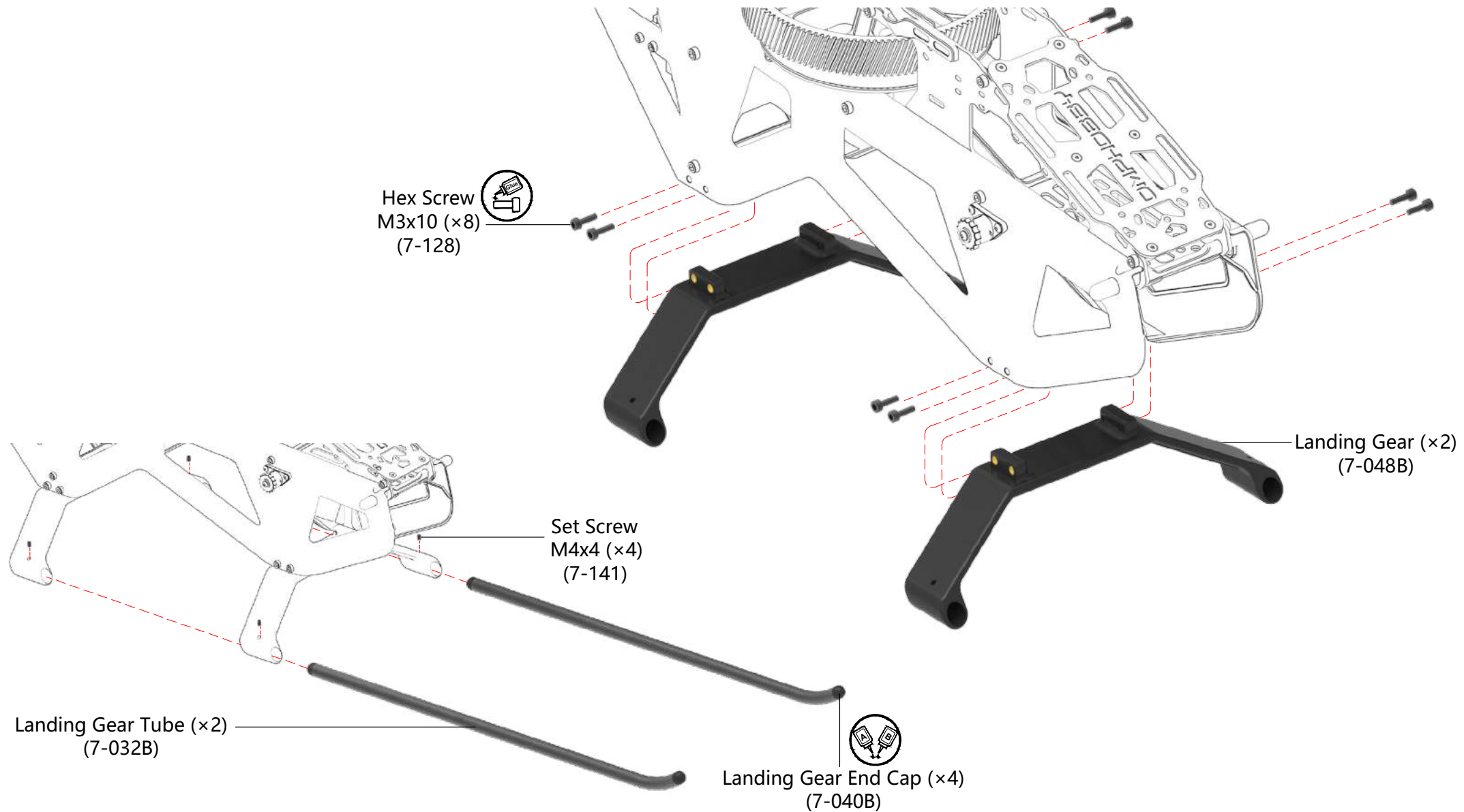

BAG 21

01 Motor Mount Installation

Hex Bolt
M3x10 (×2)
(7-128)

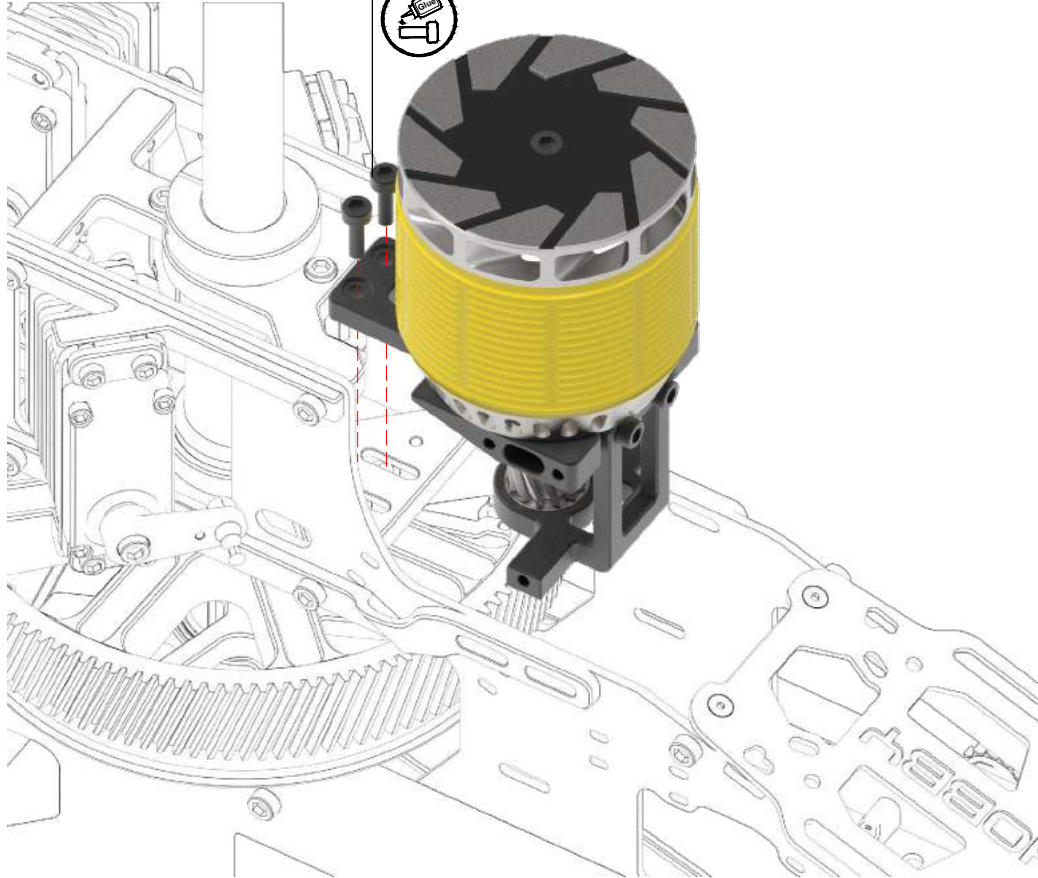

02 Motor Mount Clamping

! Before installation, insert a strip of 80g/m² paper between the motor pinion gear and the main gear, push the motor up against the main gear, then first tighten the M3x10 bolts inside the frame, then lock the motor mount in place with the M3x12 and M3x8 screws.

Washer (×6)
Φ3xΦ7x1
(7-182)

Hex Screw
M3x12 (×4)
(7-129)

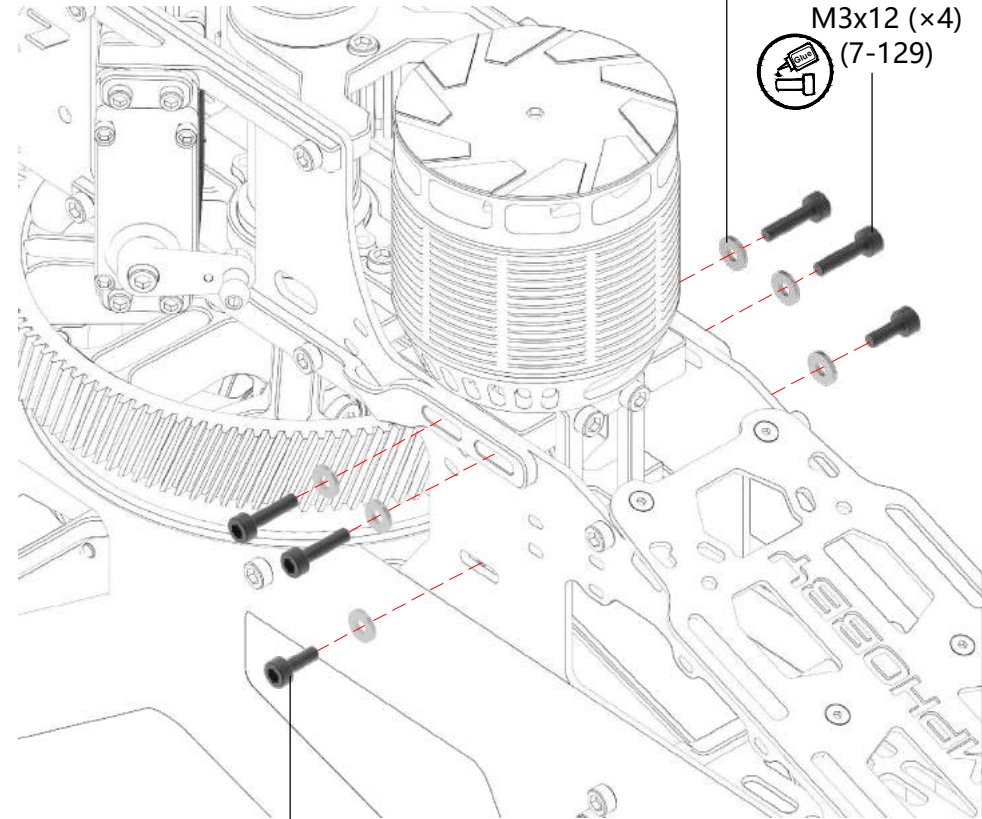

Hex Screw
M3x8 (×2)
(7-127)



! The main gear should have about 0.5mm backlash once fully installed and with the paper strip removed.

01 Vertical Tail Fin

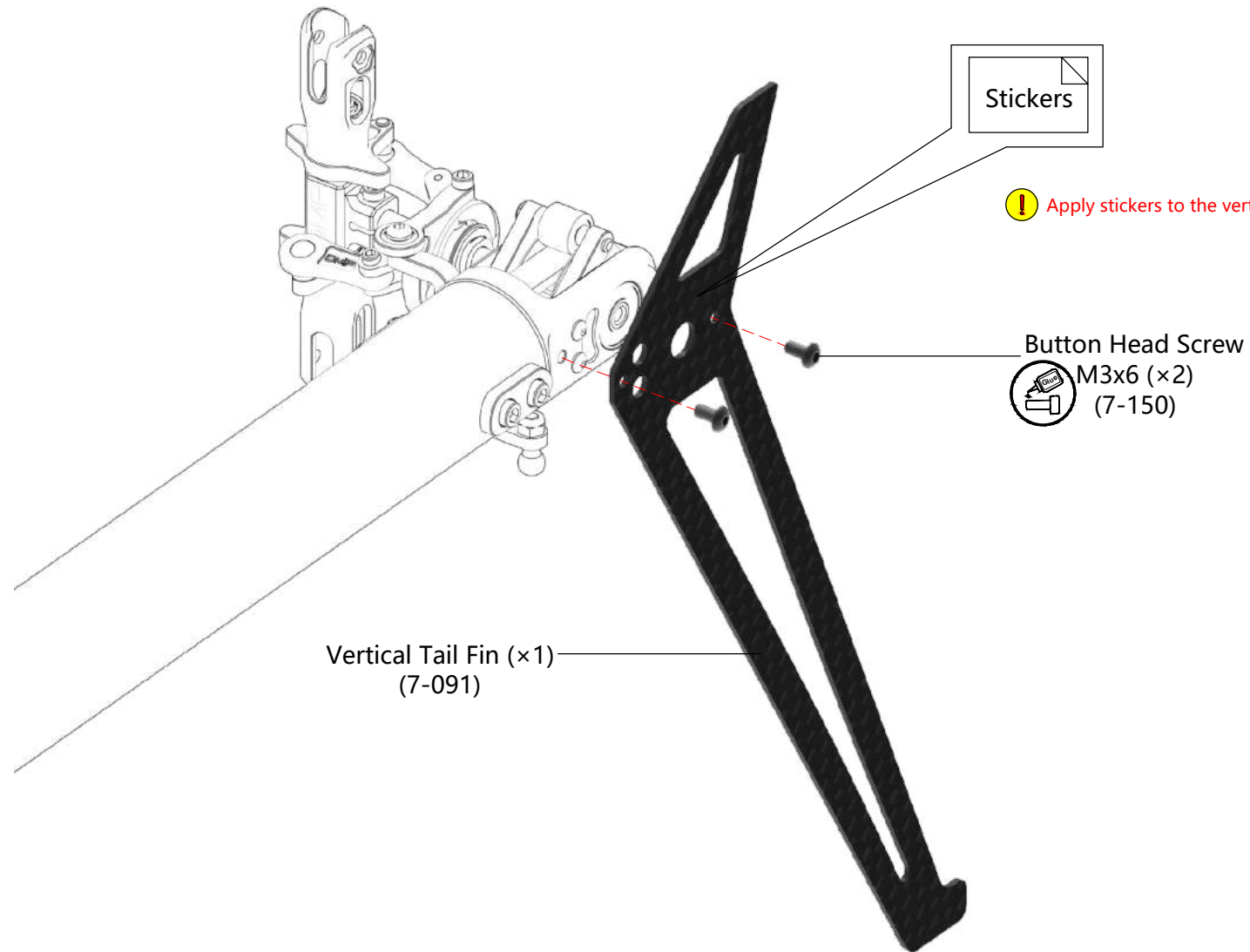

! Please refer to page 33 for the sticker placement.

BAG 23

01 Tail Control Rod Assembly

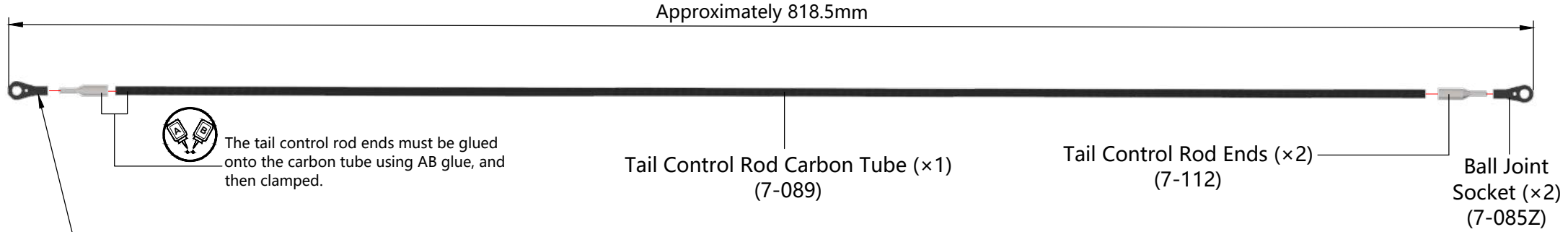

⚠ The ball joint sockets need to be installed with the OMPHOBBY logo facing outwards.

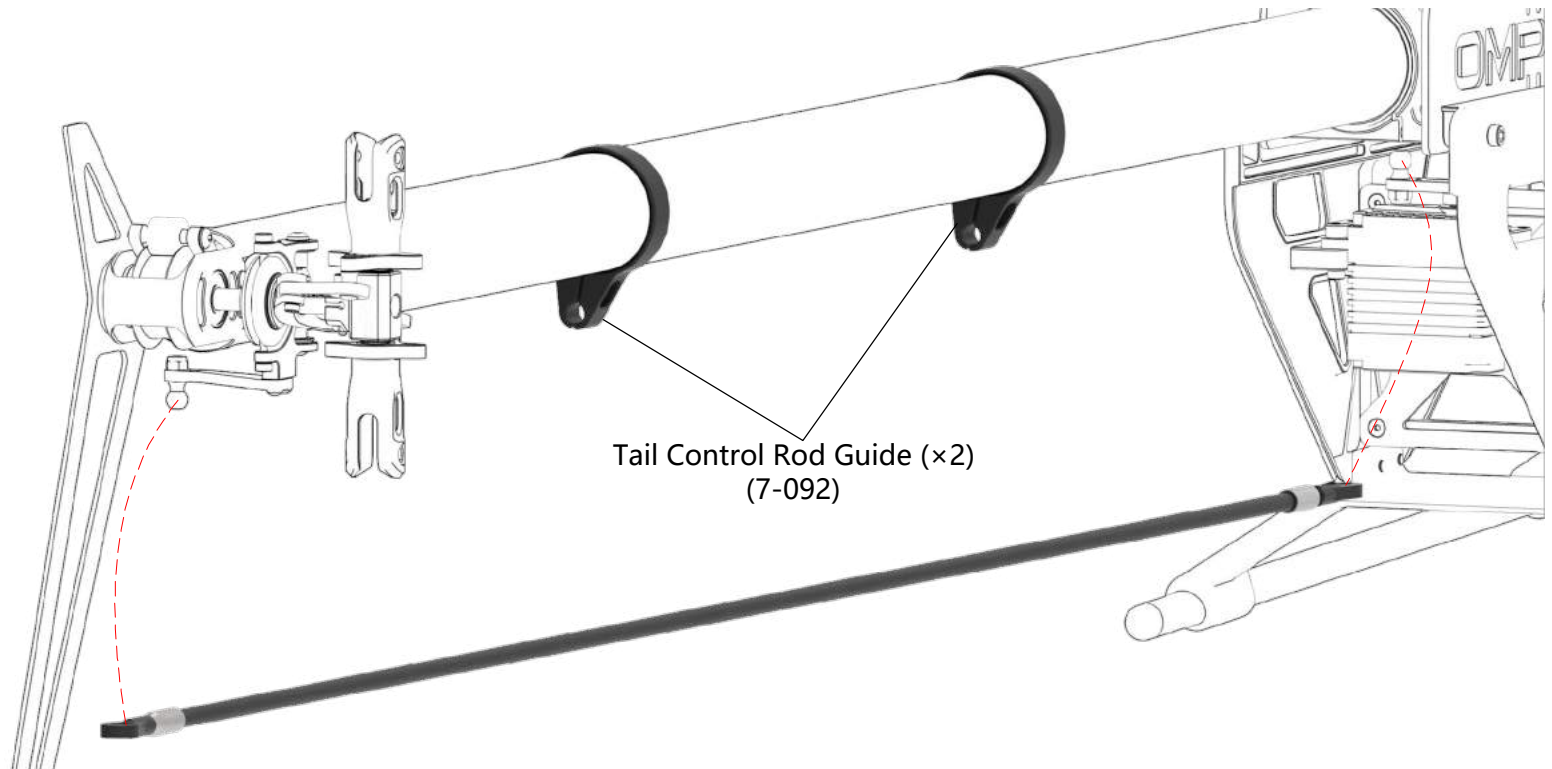

01 Tail Control Rod Guides installation and Alignment

BAG 24

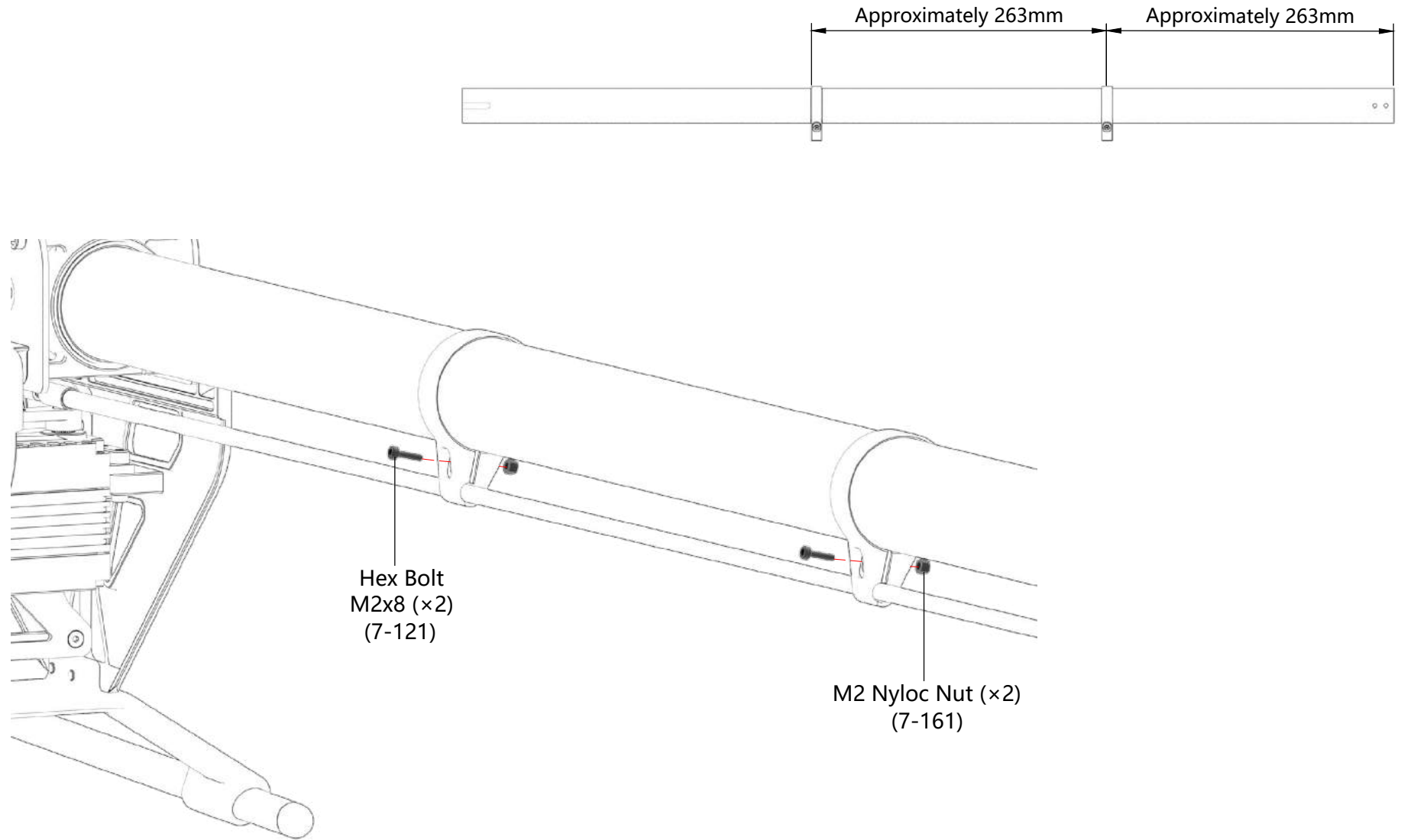

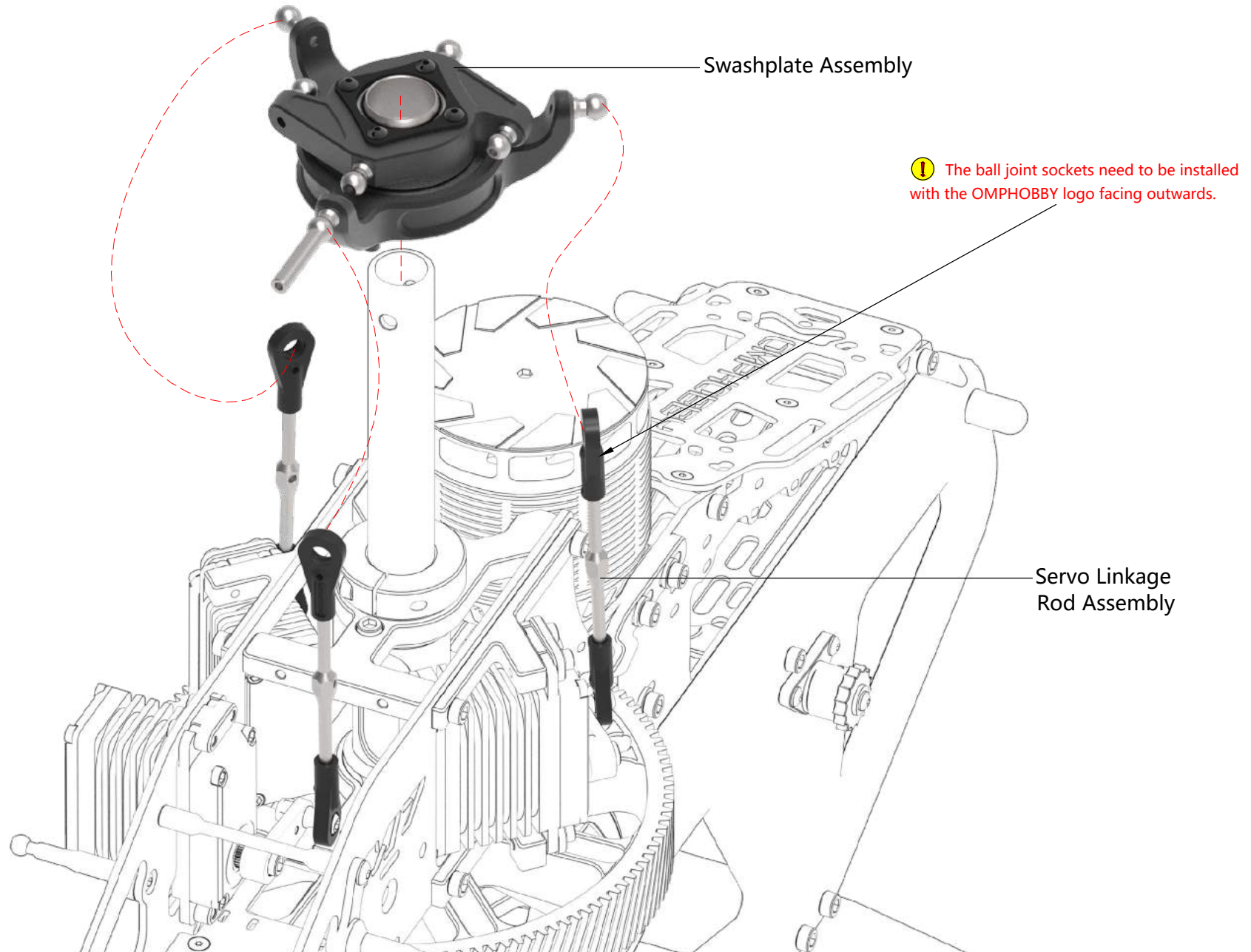
01 Swashplate Installation

01 Swashplate Guide Installation

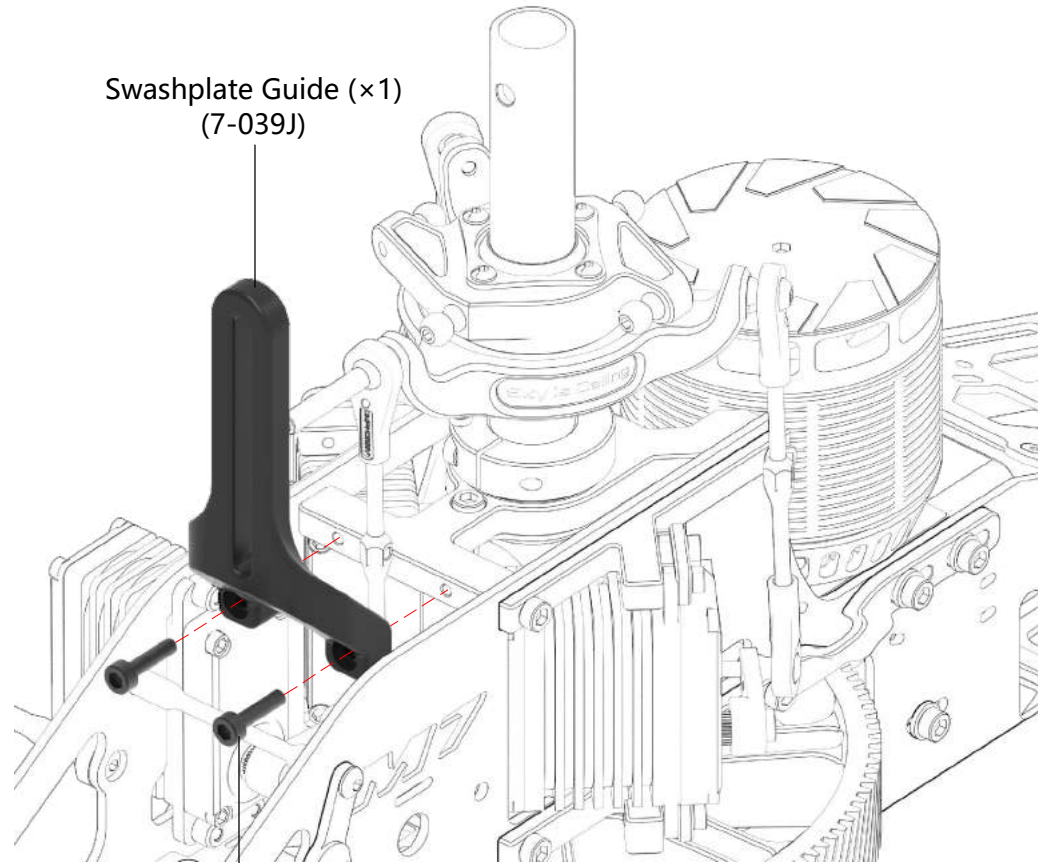

Swashplate Guide (×1)
(7-039J)



Hex Screw
M3x12 (×2)
(7-129)

BAG 26

02 Main Rotor Head Installation

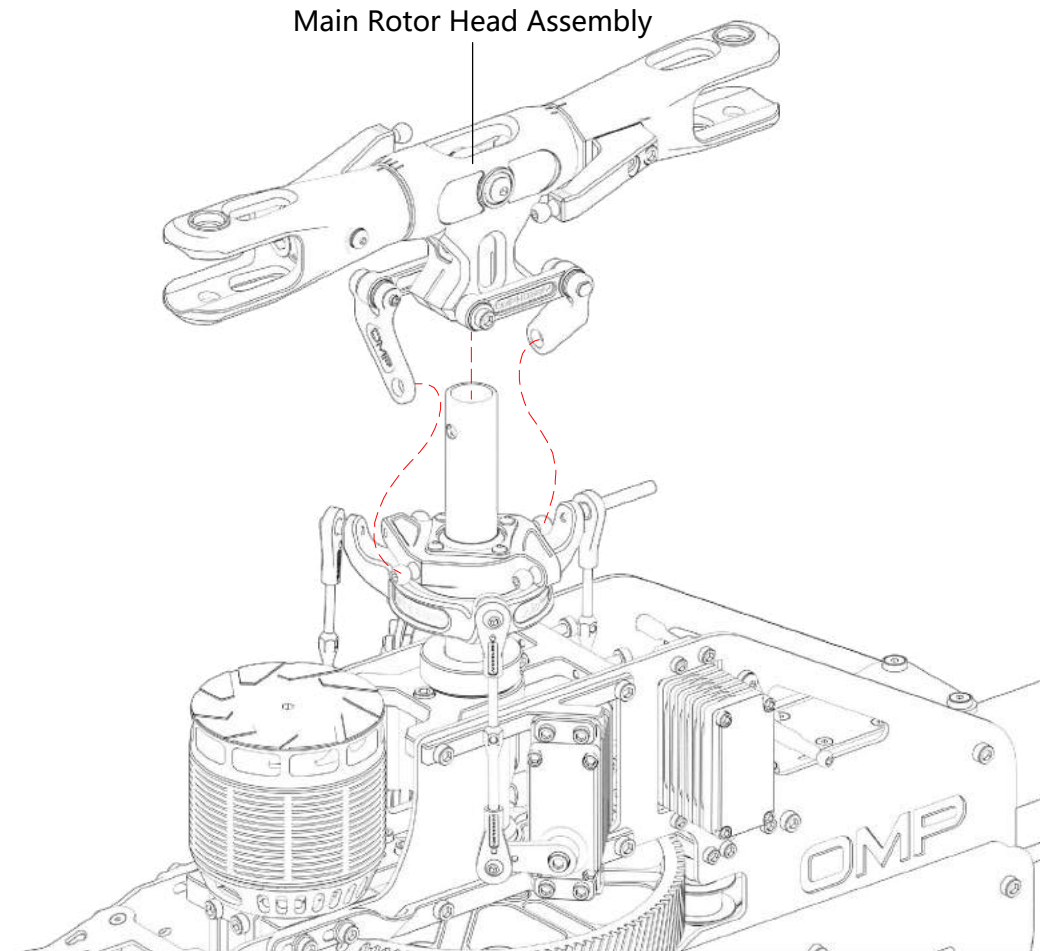

Main Rotor Head Assembly

! The swashplate driver arm screws are tightened in this step to clamp the main rotor yoke onto the main shaft. Tighten the screws evenly and in small steps to ensure proper alignment!

BAG 27

01 Main Rotor Installation

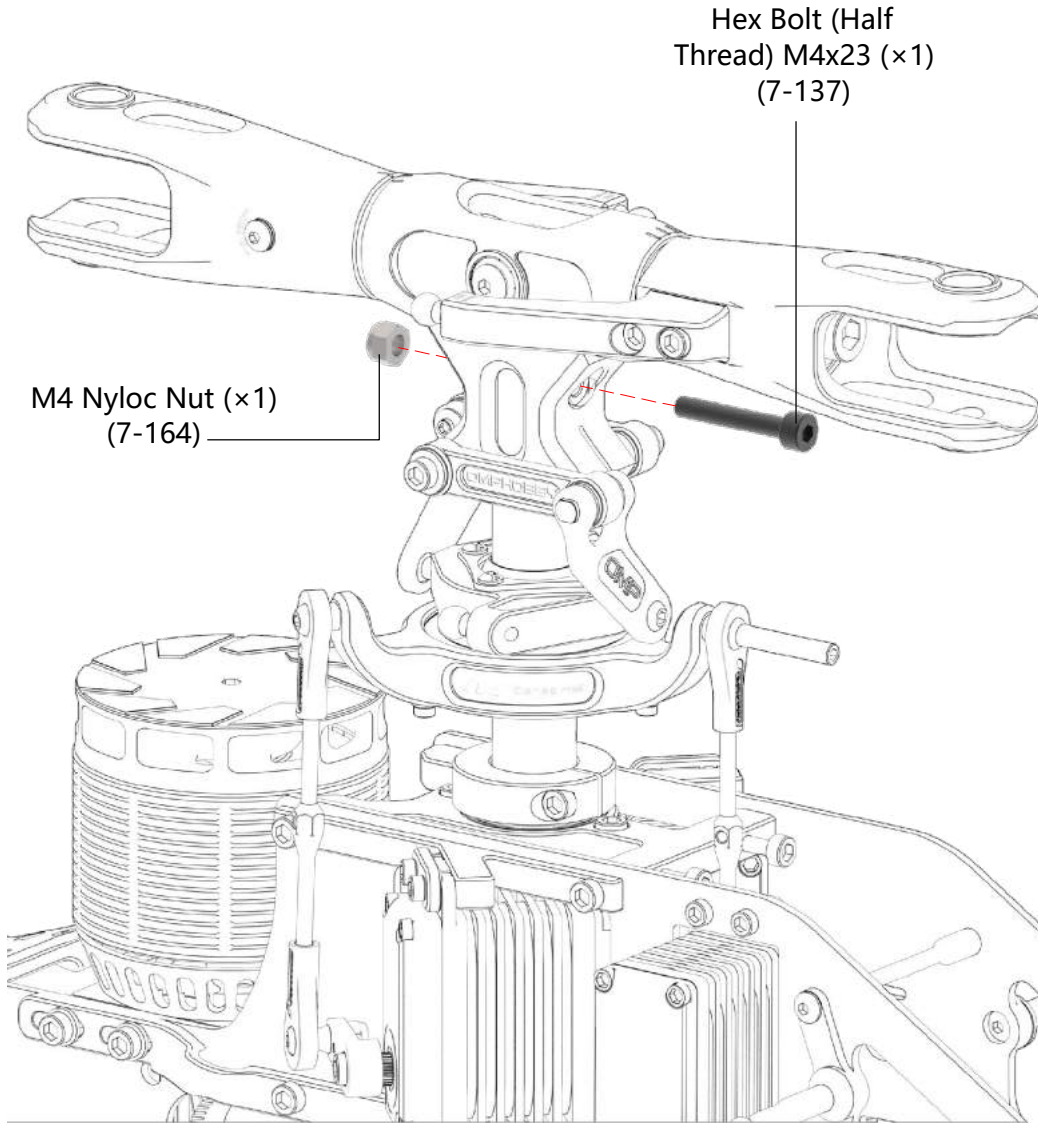

02 Main Rotor Linkage Installation

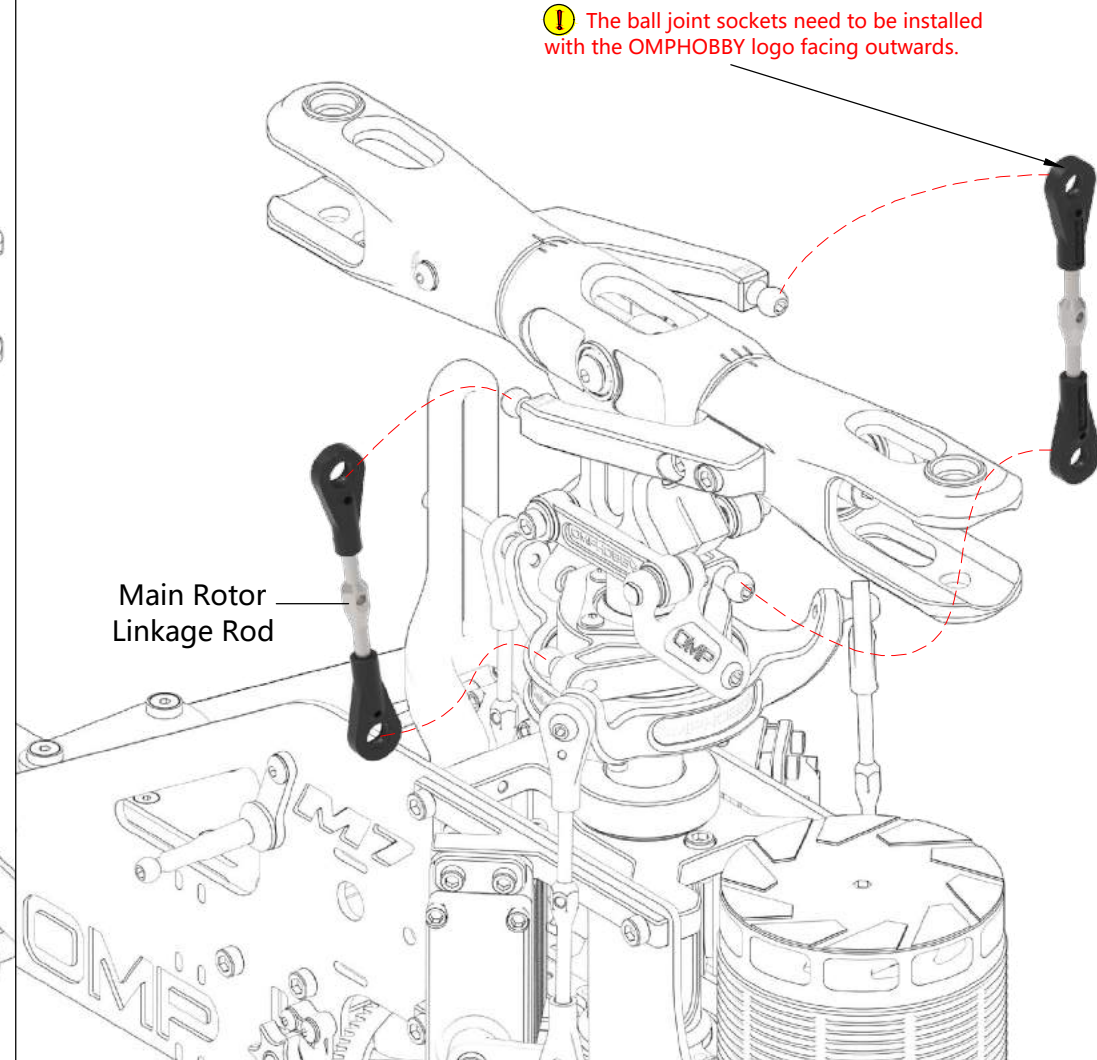

01 Main Rotor Blade Installation

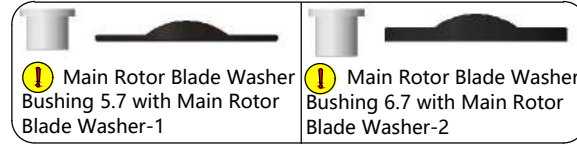

⚠ Your M7 comes with self retained rotor blade washers for both 12mm and 14mm blade roots. Please choose the appropriate thickness for your rotor blades.

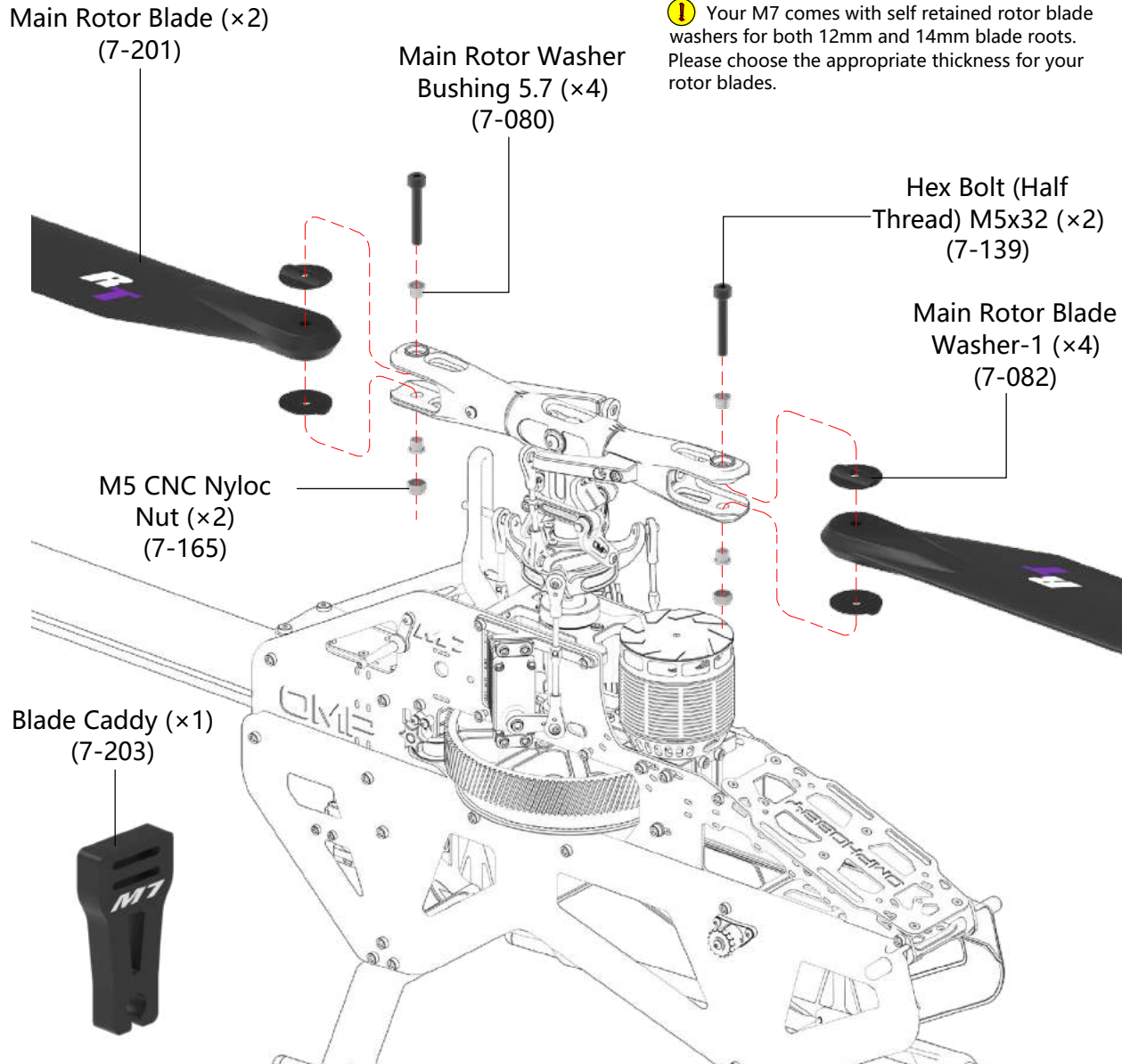

02 Tail Rotor Blade Installation

BAG 28

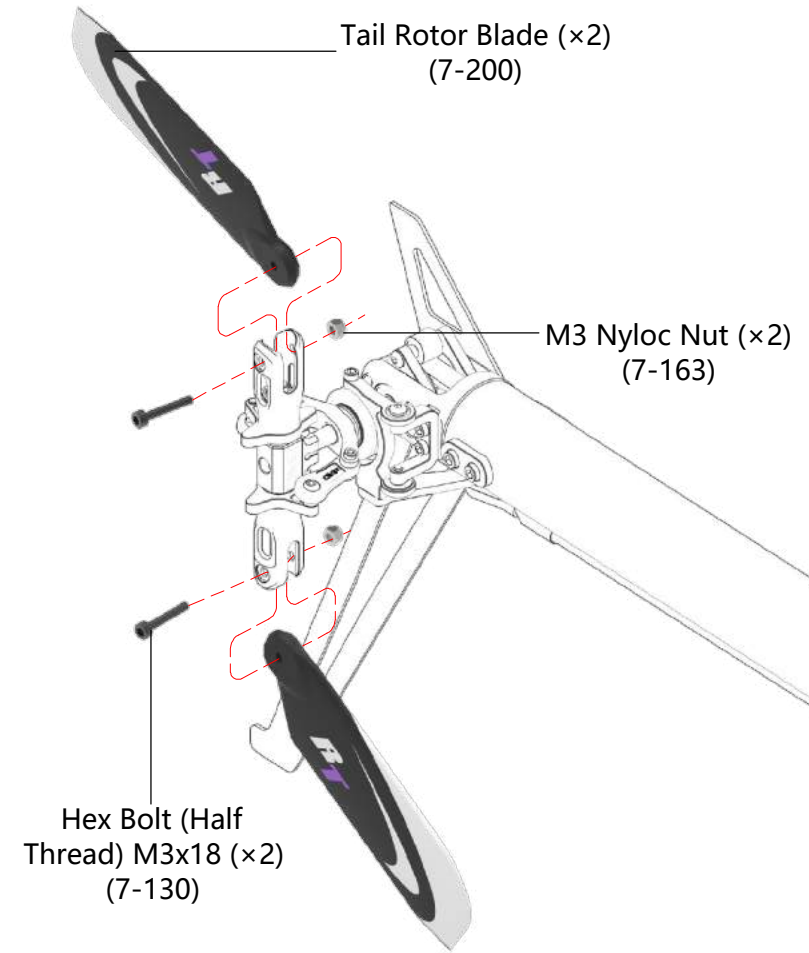

BAG 29

01 Battery Installation

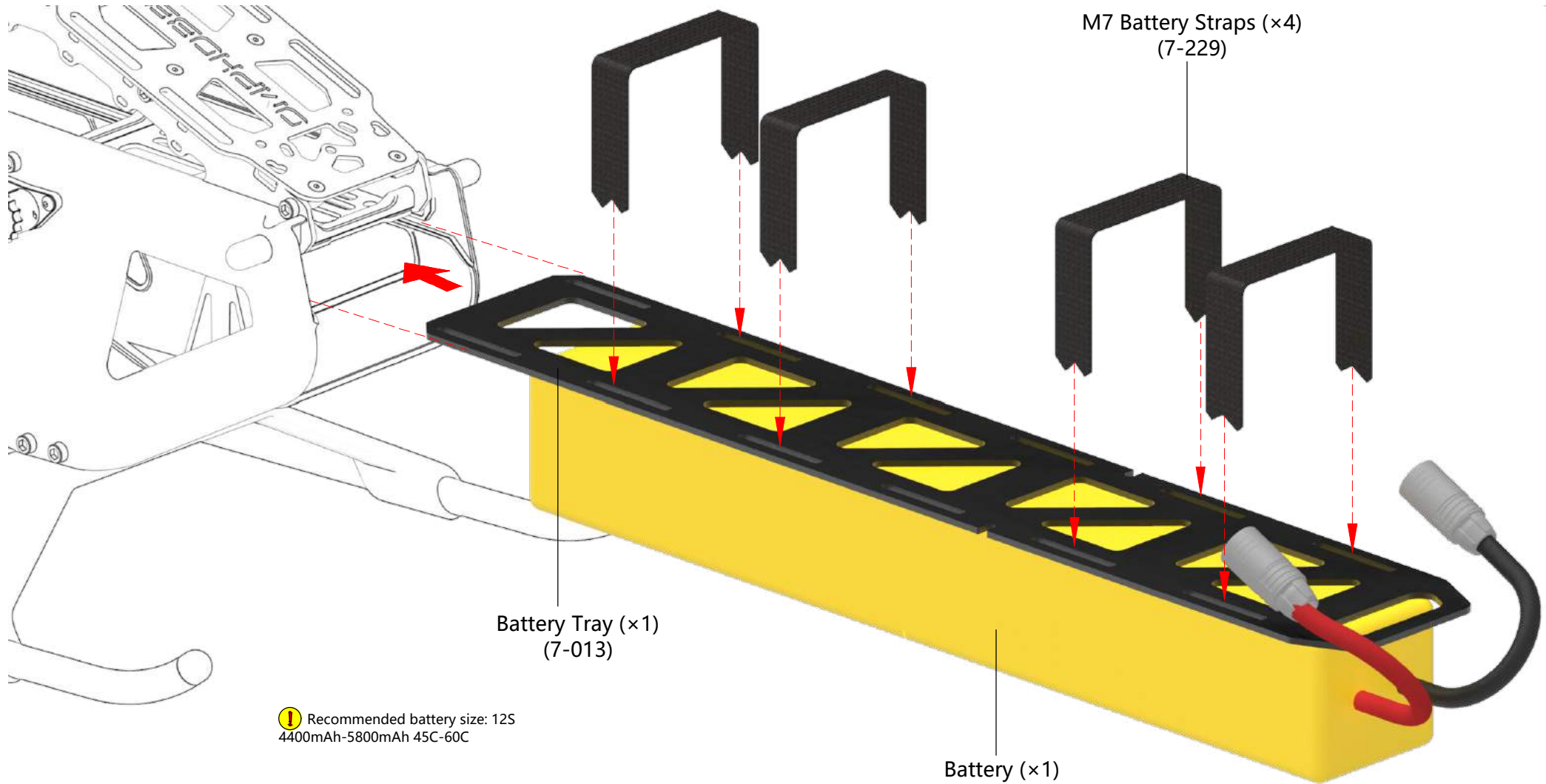

 Recommended battery size: 12S
4400mAh-5800mAh 45C-60C

01 ESC Installation

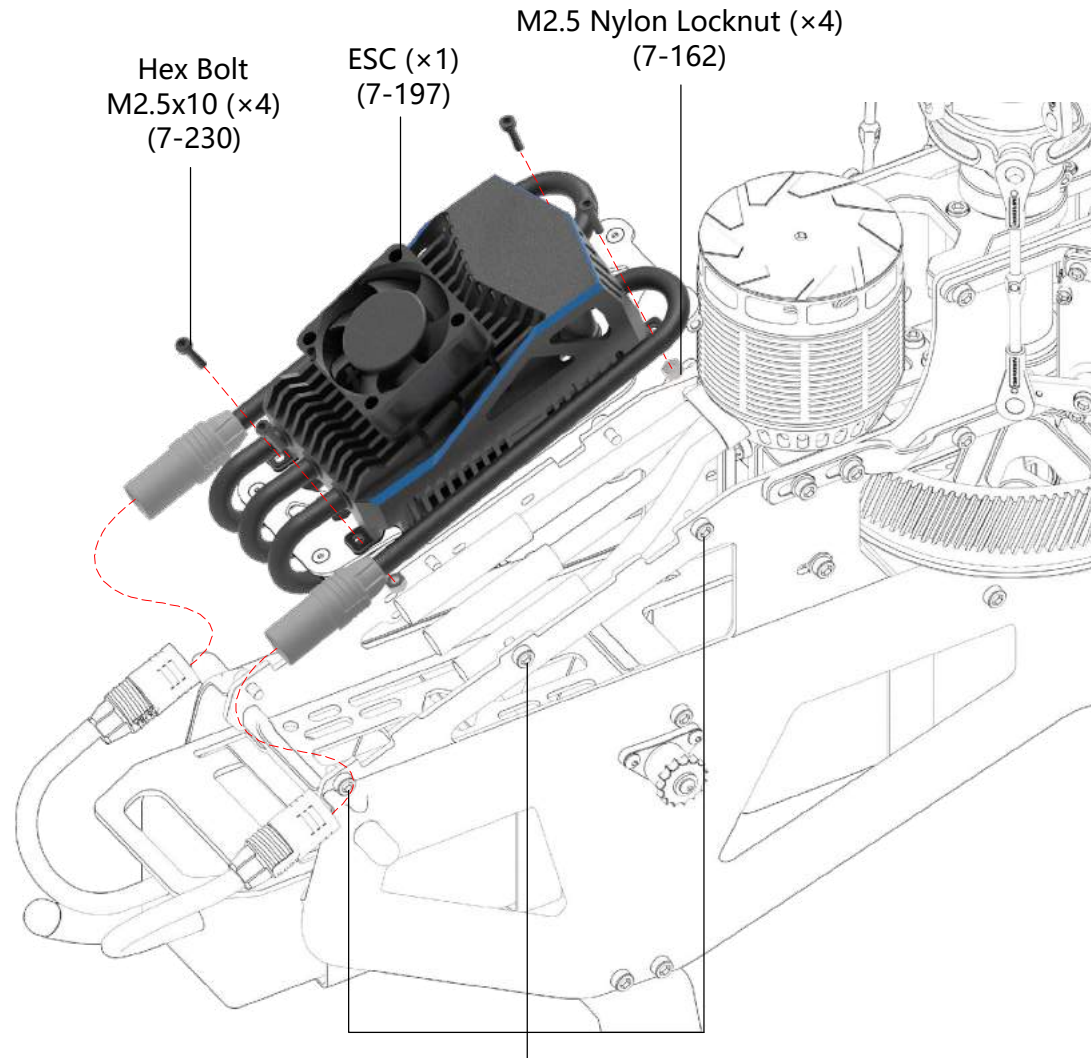

ⓘ These six screws can be removed when installing the ESC for easier installation.

02 Flight Controller Installation

BAG 30

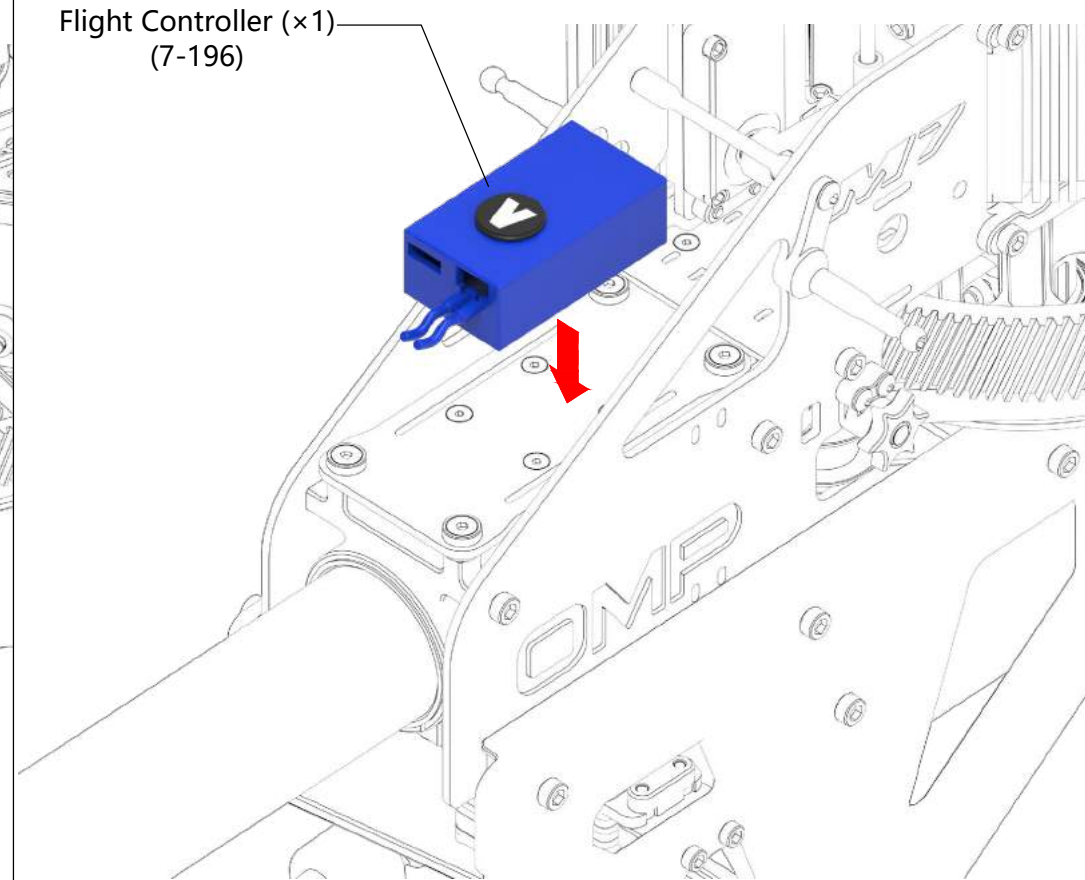





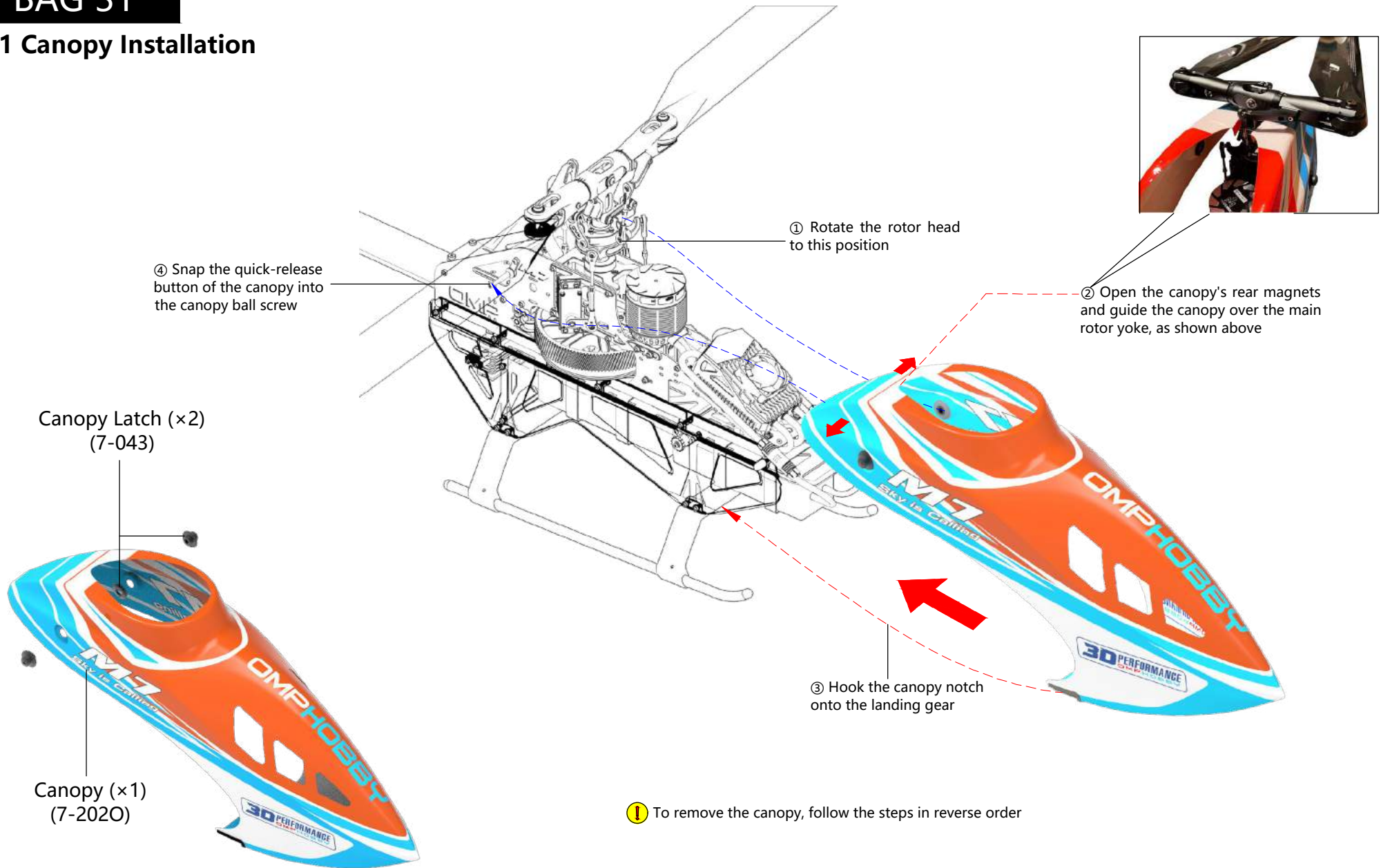



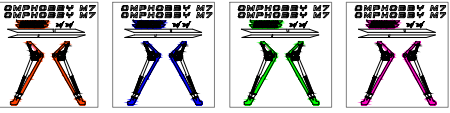

BAG 31

01 Canopy Installation



Optional and complimentary accessories included with your M7

Name	Picture	Quantity/Explain
Color Tail Boom		Color depends on your M7's canopy color
		
		
		
Metal Servo Arm		4 pcs
Stickers		Color depends on your M7's canopy color
37MM Blade Grip Arm		2 pcs
Servo Alignment Plate-V Servo Alignment Nut-V		4 pcs
Main Rotor Washer Bushing 6.7 Main Rotor Blade Washer-2		4 pcs
Battery Mounting Plate		1 pcs
POM dampers		2 pcs

Collective Pitch and Rotor Speed Recommendations

Flying Style	Recommended RPM Range	Recommended Collective Pitch Range
Sport	1500-1700RPM	±13°
Aerobatics	1600-1800RPM	±14°
Soft 3D	1700-1900RPM	±14°
Regular 3D	1800-2000RPM	±14°
Hard 3D	2100-2300RPM	±13°
Hovering	1200-1500RPM	-5° +12°
Low RPM 3D	1200-1500RPM	±15°

- Minimum RPM with POM dampers installed: 1100RPM
- Maximum Rotor Speed: 2400RPM
- Maximum Collective Pitch below 1700RPM: ±15°
- Maximum Collective Pitch 1700RPM-2100RPM: ±14°
- Maximum Collective Pitch above 2100RPM: ±13°
- Recommended Rotor Blades: Rotor Tech 700mm Ultimate

Transmission Setup

Main Gear	Pinion	Gear Ratio
120t	11t	10.91
	12t	10.00
	13t*	9.23
	14t	8.57
	15t	8.00

! Your M7 comes with a 13t pinion, which is a perfect match for 3D flying with a Kv of around 520 RPM/V. Should you be looking to run a different motor Kv or headspeed, the M7 allows for use of a wide range of motor pinions, through which you can choose the gear ratio best suited for your particular power system.

Tail boom sticker



Sticker placement on the Right side panel



Fin sticker













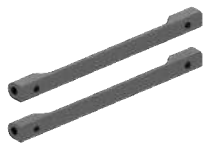











Sticker placement on the Left side panel



<p>Model: OSHM7001</p> <p>Canopy (x1) (7-2020) Canopy Latch (x2) (7-043)</p>	<p>Model: OSHM7002</p> <p>Canopy (x1) (7-202G) Canopy Latch (x2) (7-043)</p>	<p>Model: OSHM7003</p> <p>Canopy (x1) (7-202Y) Canopy Latch (x2) (7-043)</p>	<p>Model: OSHM7004</p> <p>Canopy (x1) (7-202P) Canopy Latch (x2) (7-043)</p>	<p>Model: OSHM7005</p> <p>Motor Mounting Plate (x1) (7-027) Hex Screw M4x12 (x4) (7-135) Bearing $\Phi 8 \times \Phi 16 \times 5$ (x1) (7-174)</p>	<p>Model: OSHM7006</p> <p>Motor Bearing Bracket (x1) (7-025) Hex Screw M3x8 (x4) (7-127) Washer $\Phi 3 \times \Phi 7 \times 1$ (x2) (7-182) Bearing $\Phi 8 \times \Phi 16 \times 5$ (x1) (7-174)</p>
<p>Model: OSHM7007</p> <p>L-Upper Side Frame (x1) (7-004)</p>	<p>Model: OSHM7008</p> <p>R-Upper Side Frame (x1) (7-003)</p>	<p>Model: OSHM7009</p> <p>L-Lower Side Frame (With Battery Rail) (x1) (7-002)</p>	<p>Model: OSHM7010</p> <p>R-Lower Side Frame (With Battery Rail) (x1) (7-001)</p>	<p>Model: OSHM7011</p> <p>Main Rotor Yoke (x1) (7-069) Hex Bolt (Half Thread) M4x23 (x1) (7-137) M4 Nyloc Nut (x1) (7-164)</p>	<p>Model: OSHM7012</p> <p>O-Ring 90° Shore $\Phi 20 \times 5$ (x6) (7-117) O-Ring Insert (x2) (7-079) Blade Grip Spacer (x2) (7-078)</p>
<p>Model: OSHM7013</p> <p>Main Rotor Damper (x2) (7-219) O-Ring 80° Shore $\Phi 20 \times 2.5$ (x2) (7-220) O-Ring 90° Shore $\Phi 20 \times 5$ (x2) (7-117)</p>	<p>Model: OSHM7014</p> <p>Main Rotor Blade Grip (x1) (7-070) Hex Bolt (Half Thread) M5x32 (x1) (7-139) M5 CNC Nyloc Nut (x1) (7-165) Hex Screw M6x12 (x1) (7-140) Washer $\Phi 6 \times \Phi 14 \times 2$ (x1) (7-185) Button Head Screw M3x4 (x1) (7-149) Gasket (x1) $\Phi 3 \times \Phi 6 \times 0.5$ (7-190)</p>		<p>Model: OSHM7015</p> <p>Main Rotor Shaft (x1) (7-072)</p>	<p>Model: OSHM7016</p> <p>Spindle Shaft Pivot (x1) (7-075) Button Head Screw M4x8 (x2) (7-154) Washer $\Phi 4 \times 6 \times 0.65$ (x2) (7-183) Bearing $\Phi 4 \times \Phi 12 \times 4$ (x2) (7-172)</p>	<p>Model: OSHM7017</p> <p>Spindle Shaft (x1) (7-071) Hex Screw M6x12 (x2) (7-140) Washer $\Phi 6 \times \Phi 14 \times 2$ (x2) (7-185)</p>
<p>Model: OSHM7018</p> <p>Main Blade Grip Arm-32 (x2) (7-062) Hex Screw M3x10 (x4) (7-128) Ball Joint Screw M3x$\Phi 6 \times 4.6$ (x2) (7-144)</p>	<p>Model: OSHM7019</p> <p>Main Blade Grip Arm-37 (x2) (7-063) Hex Screw M3x10 (x4) (7-128) Ball Joint Screw M3x$\Phi 6 \times 4.6$ (x2) (7-144)</p>	<p>Model: OSHM7020</p> <p>Swashplate Driver Arm (x2) (7-064) Spacer $\Phi 3 \times \Phi 4.5 \times 1.6$ (x4) (7-189) Hex Screw (Half Thread) M3x27.6 (x2) (7-133) Bearing Spacer (x2) (7-077) Flanged Bearing $\Phi 3 \times \Phi 7 \times 3$ (x8) (7-166)</p>		<p>Model: OSHM7021</p> <p>Swashplate Driver Joint (x2) (7-084) Driver Pin (x2) (7-227) Hex Screw M1.6x4 (x2) (7-226) Pin Washer (x2) (7-068) Driver Joint Bushing (x4) (7-087)</p>	
<p>Model: OSHM7022</p> <p>Servo Linkage Rod (x3) (7-074) Ball Joint Socket (x3) (7-085Z) Ball Joint Socket (x3) (7-085F)</p>	<p>Model: OSHM7023</p> <p>Rotor Head Linkage Rod (x2) (7-073) Ball Joint Socket (x2) (7-085Z) Ball Joint Socket (x2) (7-085F)</p>	<p>Model: OSHM7024</p> <p>Ball Joint Socket (x4) (7-085Z) Ball Joint Socket (x4) (7-085F)</p>	<p>Model: OSHM7025</p> <p>Swashplate Outer Ring (x1) (7-065) Swashplate Inner Ring (x1) (7-066) Swashplate Hub (x1) (7-067) Spherical Bearing Retention Plate (x1) (7-061) Spherical Bearing Races (x2) (7-086) Spherical Bearing (x1) (7-076) Button Head Screw M2.5x10 (x4) (7-148)</p> <p>Ball Joint Screw M3x$\Phi 6 \times 4.6$ (x6) (7-144) Guidance Ball Joint Screw (x1) (7-160) Hex Screw M2x5 (x3) (7-120) Washer $\Phi 2 \times \Phi 5 \times 0.5$ (x3) (7-181) Dual-Row Bearing $\Phi 30 \times \Phi 42 \times 10$ (x1) (7-178)</p>		



















<p>Model: OSHM7026</p> <p>Swashplate Outer Ring (×1) (7-065)</p>	<p>Model: OSHM7027</p> <p>Swashplate Inner Ring (×1) (7-066)</p>	<p>Model: OSHM7028</p> <p>Swashplate Hub (×1) (7-067)</p>	<p>Model: OSHM7029</p> <p>Spherical Bearing (×1) (7-076) Spherical Bearing Races (×2) (7-086)</p>	<p>Model: OSHM7031</p> <p>Swashplate Guide (×1) (7-039J) Hex Screw M3x12 (×2) (7-129)</p>	<p>Model: OSHM7032</p> <p>Main Rotor Shaft Clamp (×1) (7-031) Hex Screw M3x14 (×1) (7-224)</p>
<p>Model: OSHM7033</p> <p>Upper Coaxiality Block (×1) (7-029) Hex Screw M3x10 (×4) (7-128)</p>	<p>Model: OSHM7034</p> <p>Lower Coaxiality Block (×1) (7-026) Hex Screw M3x10 (×4) (7-128)</p>	<p>Model: OSHM7035</p> <p>Main Shaft Cover (×1) (7-028) Hex Screw M3x6 (×4) (7-126)</p>	<p>Model: OSHM7036</p> <p>Lower Bearing Block (×1) (7-020) Bearing $\Phi 15 \times \Phi 24 \times 5$ (×1) (7-177) Hex Screw (Half Thread) M3x22 (×4) (7-223)</p>	<p>Model: OSHM7037</p> <p>Tail Boom Clamp Front (×1) (keyed) (7-035) Hex Screw M3x8 (×2) (7-127) Hex Screw (Half Thread) M3x20 (×1) (7-131) Hex Screw (Half Thread) M3x32 (×1) (7-134)</p>	
<p>Model: OSHM7038</p> <p>Tail Boom Clamp Rear (×1) (round hole) (7-036) Hex Screw M3x8 (×2) (7-127) Hex Screw (Half Thread) M3x20 (×1) (7-131) Hex Screw (Half Thread) M3x32 (×1) (7-134) POM Boom Clamp Insert (×1) (7-095)</p>		<p>Model: OSHM7039</p> <p>OMP Plastic Servo Arm (×6) (7-049J)</p>	<p>Model: OSHM7040</p> <p>Metal Servo Arm (×4) (7-225)</p>	<p>Model: OSHM7041</p> <p>Tail Rotor Servo Mounting Block (×2) (7-030) Hex Screw M2.5x6 (×4) (7-122)</p>	<p>Model: OSHM7042</p> <p>Servo Alignment Plate-V (×2) (7-208) Hex Screw M2.5x12 (×4) (7-124)</p>
<p>Model: OSHM7043</p> <p>Servo Alignment Nut-V (×2) (7-209) Hex Screw M2.5x12 (×4) (7-124)</p>	<p>Model: OSHM7044</p> <p>Servo Alignment Plate (×2) (7-038) Hex Screw M2.5x12 (×4) (7-124)</p>	<p>Model: OSHM7045</p> <p>Servo Alignment Nut (×2) (7-037) Hex Screw M2.5x12 (×4) (7-124)</p>	<p>Model: OSHM7046</p> <p>Servo Mount Upper (×1) (7-050)</p>	<p>Model: OSHM7047</p> <p>Servo Mount Lower L (×1) (7-054)</p>	<p>Model: OSHM7048</p> <p>Servo Mount Lower R (×1) (7-053)</p>
<p>Model: OSHM7049</p> <p>Quick Release Knob (×1) (7-041) Quick Release Base (×1) (7-042) Quick Release Spring (×1) (7-060) Quick Release Pin (×1) (7-058) Button Head Screw M2.5x6 (×1) (7-146) Washer $\Phi 2.5 \times \Phi 7 \times 1$ (×1) (7-194) Button Head Screw M2.5x10 (×2) (7-148)</p>		<p>Model: OSHM7050</p> <p>Battery Tray (×1) (7-013) M7 Battery Straps (×4) (7-229)</p>	<p>Model: OSHM7051</p> <p>M7 Battery Straps (×4) (7-229)</p>	<p>Model: OSHM7052</p> <p>ESC Mount (×1) (7-005) Hex Screw M3x6 (×6) (7-126) Countersunk Screw M2.5x5 (×6) (7-155)</p>	<p>Model: OSHM7053</p> <p>Mounting Crossmember 45mm (×2) (7-019)</p>

<p>Model: OSHM7054</p>  <p>Flight Controller Mount (×1) (7-006) Damper Rubber (×4) (7-044) Damper Rubber Bushing (×4) (7-231) Countersunk Screw M3x12 (×4) (7-156)</p>	<p>Model: OSHM7055</p>  <p>Inertial Mass Damper (×1) (7-059) Countersunk Screw M2.5x5 (×4) (7-155)</p>	<p>Model: OSHM7056</p>  <p>Lower Aux Plate (×1) (7-007) Hex Screw M3x6 (×4) (7-126) Countersunk Screw M2.5x5 (×4) (7-155)</p>	<p>Model: OSHM7057</p>  <p>Mounting Cross Member 69mm (×2) (7-018)</p>	<p>Model: OSHM7058</p>  <p>Upper Aux Plate (×1) (7-008) Countersunk Screw M2.5x5 (×4) (7-155) Hex Screw (Half Thread) M3x26 (×2) (7-132) Canopy Support Rubber Sleeve (×2) (7-045) Hex Screw (Half Thread) M3x18 (×2) (7-130) Canopy Support Spacer (×2) (7-033)</p>	
<p>Model: OSHM7059</p>  <p>Separator Plate (×1) (7-009) Countersunk Screw M2.5x5 (×2) (7-155) Hex Screw M3x6 (×2) (7-126)</p>	<p>Model: OSHM7060</p>  <p>Main Gear 120t (×1) (7-024) Hex Screw M4x12 (×4) (7-135)</p>	<p>Model: OSHM7061</p>  <p>Sprag Clutch Housing (×1) (7-056) 15mm Sprag Clutch (×1) (7-057) Main Gear Hub (×1) (7-051) Bearing $\Phi 15 \times \Phi 21 \times 4$ (×2) (7-176)</p>	<p>Model: OSHM7062</p>  <p>Main Pulley 110t (×1) (7-052) Main Pulley Flange (×2) (7-011) Countersunk Screw M2.5x5 (×12) (7-155) Hex Bolt (Half Thread) M4x23 (×1) (7-137) M4 Nyloc Nut (×1) (7-164)</p>		<p>Model: OSHM7063</p>  <p>Tail Drive Belt (×1) (7-115)</p>
<p>Model: OSHM7064</p>  <p>Idler Pulley (×2) (7-023) Idler Cone (×1) (7-022) Hex Screw (Half Thread) M4x24 (×1) (7-138) Hex Screw (Half Thread) M4x18 (×1) (7-136) Spacer (×2) $\Phi 4 \times \Phi 6 \times 2.5$ (7-188) Bearing (×4) $\Phi 4 \times \Phi 12 \times 4$ (7-172)</p>		<p>Model: OSHM7065</p>  <p>Tensioner Mounting Base (×1) (7-021) Tensioner Pivot Reinforcement (×1) (7-015) Tensioner Lever (×1) (7-016) Countersunk Screw (×1) M3x16.2 (7-157) Hex Screw M2x8 (×2) (7-121) Spacer $\Phi 3 \times \Phi 5 \times 2.1$ (×1) (7-192) Bearing $\Phi 3 \times \Phi 8 \times 3$ (×2) (7-170)</p>		<p>Model: OSHM7066</p>  <p>Tensioner Knob (×1) (7-047) Tensioner Threaded Pin (×1) (7-046) Tensioner Base (×1) (7-014) Tensioner Screw Guidance Plate (×1) (7-012) Button Head Screw M2.5x10 (×2) (7-148)</p>	
<p>Model: OSHM7067</p>  <p>Canopy Mounting Posts (×2) (7-034) Crossmember 45mm (×1) (7-017) Canopy Ball Screw M2.5x$\Phi 5 \times 4$ (×2) (7-143) Button Head Screw M3x6 (×2) (7-150) Button Head Screw M3x8 (×2) (7-151) Canopy Mount Sacrificial Plate (×2) (7-010)</p>		<p>Model: OSHM7068</p>  <p>Landing Gear (×2) (7-048W) Hex Screw M3x10 (×8) (7-128) Set Screw M4x4 (×4) (7-141)</p>	<p>Model: OSHM7069</p>  <p>Landing Gear (×2) (7-048B) Hex Screw M3x10 (×8) (7-128) Set Screw M4x4 (×4) (7-141)</p>	<p>Model: OSHM7070</p>  <p>Landing Gear Tube (×2) (7-032W) Landing Gear End Cap (×4) (7-040W)</p>	<p>Model: OSHM7071</p>  <p>Landing Gear Tube (×2) (7-032B) Landing Gear End Cap (×4) (7-040B)</p>
<p>Model: OSHM7072</p>  <p>Carbon Tail Boom (×1) (7-088J)</p>	<p>Model: OSHM7073</p>  <p>Color Tail Boom (×1) (7-214O)</p>	<p>Model: OSHM7074</p>  <p>Color Tail Boom (×1) (214G)</p>	<p>Model: OSHM7075</p>  <p>Color Tail Boom (×1) (7-214Y)</p>	<p>Model: OSHM7076</p>  <p>Color Tail Boom (×1) (7-214P)</p>	<p>Model: OSHM7077</p>  <p>Tail Control Rod Guide (×2) (7-092) Hex Bolt M2x8 (×2) (7-121) M2 Nyloc Nut (×2) (7-161)</p>

<p>Model: OSHM7078</p>  <p>Tail Control Rod Carbon Tube (×1) (7-089) Ball Joint Socket (×2) (7-085Z) Tail Control Rod Ends (×2) (7-112)</p>	<p>Model: OSHM7079</p>  <p>Tail Pitch Slider Bridge (×1) (7-101) Tail Rotor Ball Joint Socket (×2) (7-093) Bushing $\Phi 2 \times \Phi 4 \times 3.5$ (×2) (7-193) Hex Screw M2x8 (×2) (7-121) Tail Pitch Slider Control Ring (×1) (7-094) Tail Pitch Slider Sleeve (×1) (7-113) Spacer $\Phi 8 \times \Phi 10 \times 1.45$ (×1) (7-186) Flanged Bearing $\Phi 8 \times \Phi 12 \times 3.5$ (×2) (7-169)</p>		<p>Model: OSHM7080</p>  <p>Tail Bellcrank Base (×1) (7-097) Button Head Screw (Half Thread) M3x8 (×2) (7-152) Hex Screw M2.5x8 (×2) (7-123)</p>	<p>Model: OSHM7081</p>  <p>Tail Bellcrank (×1) (7-098) Flanged Bearing $\Phi 3 \times \Phi 8 \times 3$ (×2) (7-167)</p>	<p>Model: OSHM7082</p>  <p>Tail Bellcrank Arm (×1) (7-090) Button Head Screw M2.5x8 (×2) (7-147)</p>
<p>Model: OSHM7083</p>  <p>Tail Boom Protector (×2) (7-102) Hex Screw M3x8 (×4) (7-127)</p>	<p>Model: OSHM7084</p>  <p>Tail Rotor Yoke (×1) (7-096) Hex Bolt (Half Thread) M2.5x14 (×1) (7-125) M2.5 Nyloc Nut (×1) (7-162)</p>	<p>Model: OSHM7085</p>  <p>Tail Rotor Blade Grip (×1) (7-106) Hex Screw M3x8 (×1) (7-127) Washer $\Phi 3 \times \Phi 7 \times 1$ (×1) (7-182) Spacer $\Phi 5 \times \Phi 7 \times 0.5$ (×1) (7-184)</p>	<p>Model: OSHM7086</p>  <p>Tail Rotor Shaft (×1) (7-110)</p>	<p>Model: OSHM7087</p>  <p>Tail Rotor Spindle Shaft (×1) (7-109) Hex Screw M3x8 (×2) (7-127) Washer $\Phi 3 \times \Phi 7 \times 1$ (×2) (7-182)</p>	<p>Model: OSHM7088</p>  <p>Blade Grip Spacer (×2) (7-114) O-Ring 80° Shore $\Phi 9 \times 2$ (×6) (7-116)</p>
<p>Model: OSHM7089</p>  <p>Tail Housing (×1) (7-107) Flanged Bearing $\Phi 6 \times \Phi 15 \times 5$ (×2) (7-168)</p>	<p>Model: OSHM7090</p>  <p>Vertical Tail Fin (×1) (7-091) Button Head Screw M3x6 (×2) (7-150)</p>	<p>Model: OSHM7091</p>  <p>Tail Pulley (×1) (7-108) Tail Pulley Flange R (×1) (7-099) Tail Pulley Flange L (×1) (7-100) Tail Pulley Screw (Custom) M2.5x14 (×1) (7-158)</p>		<p>Model: OSHM7092</p>  <p>Pressure Idler Arm L (×1) (7-103) Pressure Idler Arm R (×1) (7-104) Pressure Idler (×1) (7-210) Button Head Screw (Half Thread) M3x22 (×1) (7-153) Spacer $\Phi 3 \times \Phi 4 \times 2$ (×1) (7-222) Bearing $\Phi 3 \times \Phi 8 \times 3$ (×2) (7-170) Button Head Screw M2.5x8 (×4) (7-147)</p>	
<p>Model: OSHM7093</p>  <p>Button Head Screw M2.5x6 (×8) (7-146)</p>	<p>Model: OSHM7094</p>  <p>Button Head Screw M2.5x8 (×8) (7-147)</p>	<p>Model: OSHM7095</p>  <p>Button Head Screw M2.5x10 (×8) (7-148)</p>	<p>Model: OSHM7096</p>  <p>Button Head Screw M3x4 (×8) (7-149)</p>	<p>Model: OSHM7097</p>  <p>Button Head Screw M3x6 (×8) (7-150)</p>	<p>Model: OSHM7098</p>  <p>Button Head Screw M3x8 (×8) (7-151)</p>
<p>Model: OSHM7099</p>  <p>Button Head Screw (Half Thread) M3x8 (×8) (7-152)</p>	<p>Model: OSHM7100</p>  <p>Button Head Screw (Half Thread) M3x22 (×8) (7-153)</p>	<p>Model: OSHM7101</p>  <p>Button Head Screw M4x8 (×8) (7-154)</p>	<p>Model: OSHM7102</p>  <p>Hex Screw M1.6x4 (×8) (7-226)</p>	<p>Model: OSHM7103</p>  <p>Hex Screw M2x5 (×8) (7-120)</p>	<p>Model: OSHM7104</p>  <p>Hex Screw M2x8 (×8) (7-121)</p>

<p>Model: OSHM7105</p> <p>Hex Screw M2.5x6 (x8) (7-122)</p>	<p>Model: OSHM7106</p> <p>Hex Screw M2.5x8 (x8) (7-123)</p>	<p>Model: OSHM7107</p> <p>Hex Screw M2.5x12 (x8) (7-124)</p>	<p>Model: OSHM7108</p> <p>Hex Bolt (Half Thread) M2.5x14 (x8) (7-125)</p>	<p>Model: OSHM7109</p> <p>Hex Screw M3x6 (x8) (7-126)</p>	<p>Model: OSHM7110</p> <p>Hex Screw M3x8 (x8) (7-127)</p>
<p>Model: OSHM7111</p> <p>Hex Screw M3x10 (x8) (7-128)</p>	<p>Model: OSHM7112</p> <p>Hex Screw M3x12 (x8) (7-129)</p>	<p>Model: OSHM7113</p> <p>Hex Bolt (Half Thread) M3x18 (x8) (7-130)</p>	<p>Model: OSHM7114</p> <p>Hex Screw (Half Thread) M3x20 (x8) (7-131)</p>	<p>Model: OSHM7115</p> <p>Hex Screw (Half Thread) M3x22 (x8) (7-223)</p>	<p>Model: OSHM7116</p> <p>Hex Screw (Half Thread) M3x26 (x8) (7-132)</p>
<p>Model: OSHM7117</p> <p>Hex Screw (Half Thread) M3x27.6 (x8) (7-133)</p>	<p>Model: OSHM7118</p> <p>Hex Screw (Half Thread) M3x32 (x8) (7-134)</p>	<p>Model: OSHM7119</p> <p>Hex Screw M4x12 (x8) (7-135)</p>	<p>Model: OSHM7120</p> <p>Hex Screw (Half Thread) M4x18 (x8) (7-136)</p>	<p>Model: OSHM7121</p> <p>Hex Bolt (Half Thread) M4x23 (x2) (7-137) M4 Nyloc Nut (x2) (7-164)</p>	<p>Model: OSHM7122</p> <p>Hex Screw (Half Thread) M4x24 (x8) (7-138)</p>
<p>Model: OSHM7123</p> <p>Hex Bolt (Half Thread) M5x32 (x2) (7-139) M5 CNC Nyloc Nut (x2) (7-165) Main Rotor Washer Bushing 5.7 (x4) (7-080) Main Rotor Blade Washer-1 (x4) (7-082)</p>		<p>Model: OSHM7124</p> <p>Hex Bolt (Half Thread) M5x32 (x2) (7-139) M5 CNC Nyloc Nut (x2) (7-165) Main Rotor Washer Bushing 6.7 (x4) (7-081) Main Rotor Blade Washer-2 (x4) (7-083)</p>		<p>Model: OSHM7125</p> <p>Tail Pulley Screw (Custom) M2.5x14 (x4) (7-158)</p>	<p>Model: OSHM7126</p> <p>Driver Pin (x4) (7-227)</p>
<p>Model: OSHM7127</p> <p>Set Screw M4x4 (x8) (7-141)</p>	<p>Model: OSHM7128</p> <p>Set Screw M4x5 (x8) (7-142)</p>	<p>Model: OSHM7129</p> <p>Guidance Ball Joint Screw (x2) (7-160)</p>	<p>Model: OSHM7130</p> <p>Canopy Ball Screw M2.5xΦ5x4 (x4) (7-143)</p>	<p>Model: OSHM7131</p> <p>Ball Joint Screw M3xΦ6x4.6 (x4) (7-144)</p>	<p>Model: OSHM7132</p> <p>Ball Joint Screw M3xΦ6x6.7 (x4) (7-145)</p>

<p>Model: OSHM7133</p> <p>M2 Nyloc Nut (x8) (7-161)</p>	<p>Model: OSHM7134</p> <p>M2.5 Nyloc Nut (x8) (7-162)</p>	<p>Model: OSHM7135</p> <p>M3 Nyloc Nut (x8) (7-163)</p>	<p>Model: OSHM7136</p> <p>M4 Nyloc Nut (x8) (7-164)</p>	<p>Model: OSHM7137</p> <p>M5 CNC Nyloc Nut (x4) (7-165)</p>	<p>Model: OSHM7138</p> <p>Bushing Φ2xΦ4x3.5 (x6) (7-193)</p>
<p>Model: OSHM7139</p> <p>Washer Φ2xΦ5x0.5 (x6) (7-181)</p>	<p>Model: OSHM7140</p> <p>Washer Φ2.5xΦ7x1 (x6) (7-194)</p>	<p>Model: OSHM7141</p> <p>Spacer Φ3xΦ4.5x1.6 (x6) (7-189)</p>	<p>Model: OSHM7142</p> <p>Spacer Φ3xΦ5x2.1 (x6) (7-192)</p>	<p>Model: OSHM7143</p> <p>Gasket Φ3xΦ6x0.5 (x6) (7-190)</p>	<p>Model: OSHM7144</p> <p>Washer Φ3xΦ7x1 (x6) (7-182)</p>
<p>Model: OSHM7145</p> <p>Washer Φ4x6x0.65 (x6) (7-183)</p>	<p>Model: OSHM7146</p> <p>Spacer Φ4xΦ6x2.5 (x6) (7-188)</p>	<p>Model: OSHM7147</p> <p>Spacer Φ5xΦ7x0.5 (x6) (7-184)</p>	<p>Model: OSHM7148</p> <p>Washer Φ6xΦ14x2 (x6) (7-185)</p>	<p>Model: OSHM7149</p> <p>Spacer Φ8xΦ10x1.45 (x6) (7-186)</p>	<p>Model: OSHM7150</p> <p>Thrust Bearing Washer Φ10xΦ14x1 (x6) (7-187)</p>
<p>Model: OSHM7151</p> <p>Spacer Φ15.1xΦ17x1.6 (x6) (7-191)</p>	<p>Model: OSHM7152</p> <p>Flanged Bearing Φ3xΦ7x3 (x2) (7-166)</p>	<p>Model: OSHM7153</p> <p>Flanged Bearing Φ3xΦ8x3 (x2) (7-167)</p>	<p>Model: OSHM7154</p> <p>Flanged Bearing Φ6xΦ15x5 (x2) (7-168)</p>	<p>Model: OSHM7155</p> <p>Flanged Bearing Φ8xΦ12x3.5 (x2) (7-169)</p>	<p>Model: OSHM7156</p> <p>Axial Bearing Φ5xΦ10x4 (x2) (7-179)</p>
<p>Model: OSHM7157</p> <p>Axial Bearing Φ10xΦ18x5.5 (x2) (7-180)</p>	<p>Model: OSHM7158</p> <p>Bearing Φ3xΦ8x3 (x2) (7-170)</p>	<p>Model: OSHM7159</p> <p>Bearing Φ4xΦ12x4 (x2) (7-172)</p>	<p>Model: OSHM7160</p> <p>Bearing Φ5xΦ10x4 (x2) (7-173)</p>	<p>Model: OSHM7161</p> <p>Bearing Φ8xΦ16x5 (x2) (7-174)</p>	<p>Model: OSHM7162</p> <p>Bearing Φ10xΦ19x7 (x2) (7-175)</p>

<p>Model: OSHM7163</p>  <p>Bearing $\Phi 15 \times \Phi 21 \times 4$ (x1) (7-176)</p> <p>Model: OSHM7169</p>	<p>Model: OSHM7164</p>  <p>Bearing $\Phi 15 \times \Phi 24 \times 5$ (x1) (7-177)</p> <p>Model: OSHM7030</p>	<p>Model: OSHM7165</p>  <p>Bearing $\Phi 15 \times \Phi 24 \times 7$ (x1) (7-204)</p> <p>Model: OSHM7170</p>	<p>Model: OSHM7166</p>  <p>Bearing $\Phi 30 \times \Phi 42 \times 10$ (x1) (7-178)</p> <p>Model: OSHM7171</p>	<p>Model: OSHM7167</p>  <p>Blade Caddy (x1) (7-203)</p> <p>Model: OSHM7172</p>	<p>Model: OSHM7168</p>  <p>Main Rotor Blade (x2) (7-201)</p> <p>Model: OSHM7173</p>
 <p>Tail Rotor Blade (x2) (7-200)</p> <p>Model: OSHM7174</p>	 <p>300A ESC (x1) (7-197)</p> <p>Model: OSHM7175</p>	 <p>R4530 Motor (x1) (7-195)</p> <p>Model: OSHM7176</p>	 <p>Pinion Gear 13t (x1) (7-055) Set Screw M4x5 (x1) (7-142) Set Screw M4x4 (x1) (7-141)</p> <p>Model: OSHM7177</p>	 <p>Pinion Gear 11t (x1) (7-235) Set Screw M4x5 (x1) (7-142) Set Screw M4x4 (x1) (7-141)</p> <p>Model: OSHM7178</p>	 <p>Pinion Gear 12t (x1) (7-236) Set Screw M4x5 (x1) (7-142) Set Screw M4x4 (x1) (7-141)</p> <p>Model: OSHM7179</p>
 <p>Pinion Gear 14t (x1) (7-237) Set Screw M4x5 (x1) (7-142) Set Screw M4x4 (x1) (7-141)</p> <p>Model: OSHM7180</p>	 <p>Pinion Gear 15t (x1) (7-238) Set Screw M4x5 (x1) (7-142) Set Screw M4x4 (x1) (7-141)</p>	 <p>Swashplate Levelling Tool (x1) (7-215)</p>	 <p>Orange Sticker (x1) (7-239)</p>	 <p>Blue Sticker (x1) (7-240)</p>	 <p>Green Sticker (x1) (7-241)</p>
 <p>Pink Sticker (x1) (7-242)</p>					

OMPHOBBY®

www.omphobby.com

The information, photos, and instructions contained in this manual are the property of OMPHOBBY and may not be copied or distributed without authorization.

Furthermore, OMPHOBBY reserves the right to modify any information in this manual.

This manual is subject to change without prior notice.

You can verify the latest version of the OMPHOBBY www.omphobby.com official website.

Carefully check your model before each flight to ensure it is airworthy.

Consider flying only in areas dedicated to the use of model helicopters.

Check and inspect the flying area to ensure it is clear of people and obstacles.

Rotor blades can rotate at very high speeds! Be aware of the danger they pose.

Always keep the model at a safe distance from other pilots and spectators.

Avoid maneuvers with trajectories towards a crowd.

Always maintain a safe distance from the model.