

ASCENT 18

1/18 Scale Crawler



MOST RECENT FULL
ONLINE MANUAL

INCLUDED

- Ascent:** Assembled with electronics
- Radio System:** 2.4GHz
- Rechargeable Battery:** 2S LIPO Battery W/ JST connector
- Battery Charger:** USB Charge Cable

REQUIRED

- Transmitter Batteries:** Four AA batteries

IMPORTANT LINKS:

- To view the full length manual with ESC guide, Radio guide, exploded views and parts lists, go to: www.redcatracing.com/pages/manuals
- Link to electric vehicles manual: www.redcatracing.com/manuals/ELECTRIC-MANUAL.pdf



Warnings

AGE WARNING! You must be 14 years of age or older to operate this vehicle. It is the buyer's responsibility to ensure that this product is safely operated. This radio controlled (RC) vehicle is not a toy. It is the responsibility of the parents or guardian to ensure that minors receive appropriate guidance and supervision when operating or working on this product.

The buyer assumes all risks associated with the use of this product. Namero LLC d/b/a Redcat Racing and their retail partners, dealers, distributors, manufactures and affiliates cannot control the use and operation of this product and as such shall not be held responsible or liable for any injury, accident or damage resulting from the use of this product.

Always perform a pre-run inspection to ensure that there is no damage and that all screws and wheel nuts are secure. If damage is found, repair or replace prior to use.

Fully read all instructions, manuals and warnings that come with your RC vehicle and any accessories required to operate the product.

Never operate your RC vehicles on public roads, near bystanders, children, pets or other animals. Never lose sight of your vehicle while it is in operation and always leave a safe distance around your RC vehicles when driving so that in the event you lose control you don't damage the vehicle, hurt yourself or others. Always keep clear of the wheels or other moving parts on the vehicle and never attempt to pick up the vehicle if the wheels are in motion. Do not attempt to touch the motor, ESC, battery or other electrical components during or immediately after use as these items will get hot during operation.

Always allow the vehicle time to cool down between runs. Overheating the electronics can shorten the life of your electronic components.

Never leave the battery connected when not in use and store batteries in accordance with the manufactures instructions.

Never leave a battery unattended while being charged. Never charge batteries while they are inside of the RC vehicle.

There is a risk of fire and explosion when dealing with batteries. Rechargeable batteries may become hot and catch fire if left unattended, charged too quickly, charged too often, if overcharged, if over discharged or if previously damaged. Never charge at a rate higher than 1C. (2000Mah pack = 2 amp charge rate). Always use a LIPO safe charging pouch when charging LIPO batteries. Only use a LIPO specific charger when charging LIPO batteries.

Never use a LIPO battery that has previously overheated and/or shows signs of damage or swelling. If you suspect the battery to be damaged, immediately discontinue use and properly dispose of the battery. Never dispose of a LIPO battery with regular trash, check with local authorities for proper disposal. Always check the ESC settings to ensure that they match the battery type during operation. If using a LIPO battery, the ESC must be set to LIPO or damage may occur.

Never mix old and new batteries. Do not change or charge batteries in a hazardous location. Do not mix alkaline, lithium, standard (carbon zinc), or rechargeable (NiMH, cadmium) batteries.

If you do not agree with or are unable to follow these warnings and are not willing to accept full and complete liability for the use of this RC product, immediately return the product to your place of purchase in new and unused condition.

Start Up

Attention: The ESC only accepts 2S LIPO batteries. Only use a 2S LIPO battery.

1. Insert 4 brand new AA batteries into the controller. Be sure to line up the positive (+) side of the battery with the (+) mark inside the battery compartment. (see above warnings)

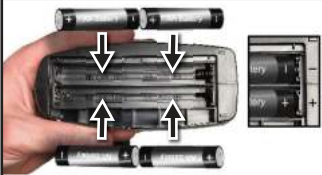

2. Turn the rear 1/4 body fastener and tilt the body forward. Unclick front hinge to remove.



3. Strap in a fully charged battery pack.

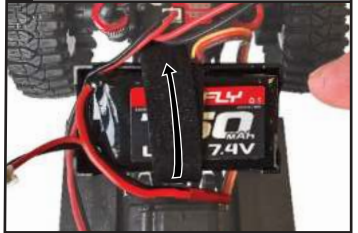

4. Plug in the battery. CAUTION! Do not turn on the ESC yet!



5. Turn on the radio.

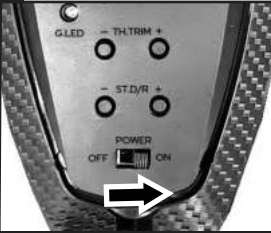

6. Turn on the ESC and secure the body in place.

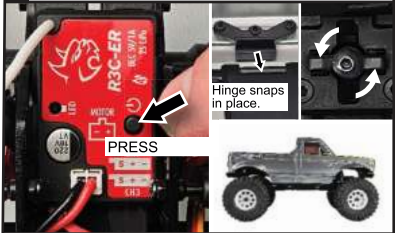

Steering

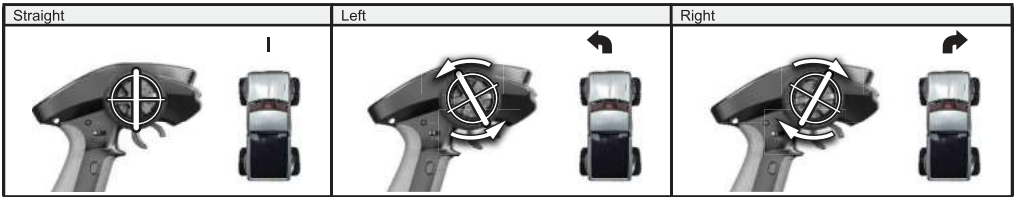

Throttle

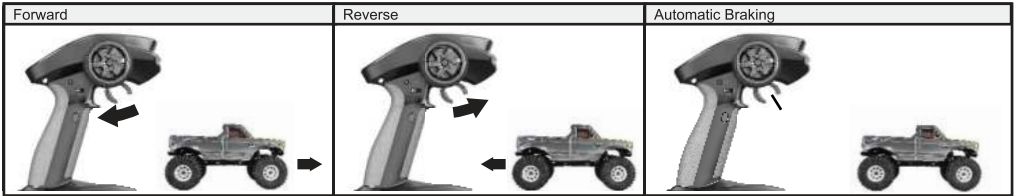

Shut Down

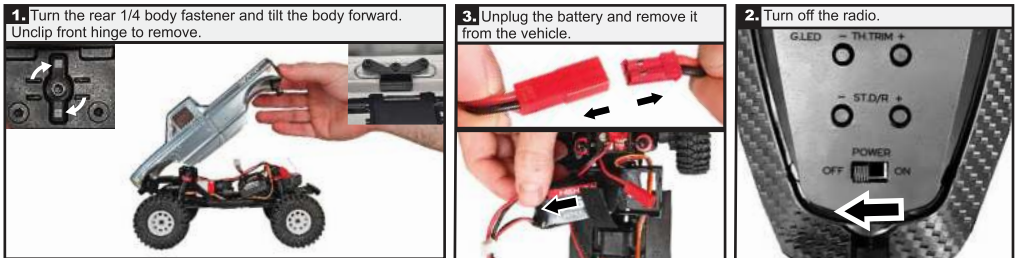

Radio Adjustments

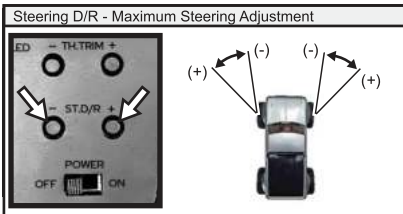
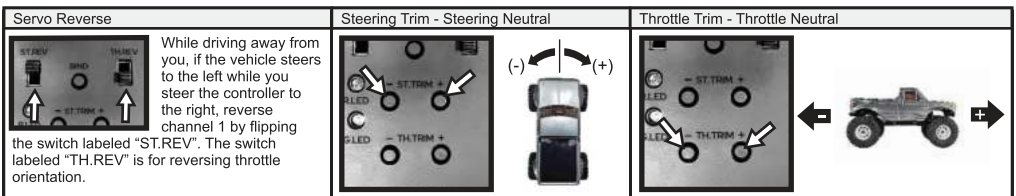

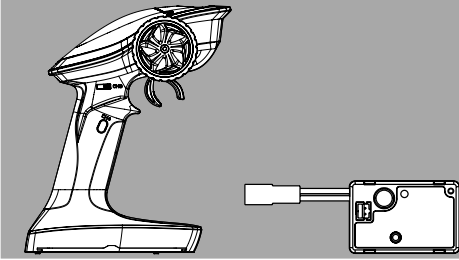

Warnings & Compliance



FCC Compliance Statement! The radio included with your vehicle complies with part 15 of the FCC Rules. Operation is subject to the following two conditions: (1) This device may not cause harmful Interference, and (2) This device must accept any interference received, including interference that may cause undesired operations.

Note: This equipment has been tested and found to comply with the limits for a Class B digital device, pursuant to Part 15 of the FCC Rules.

These limits are designed to provide reasonable protection against harmful interference in a residential installation. This equipment generates, uses and can radiate radio frequency energy and, if not installed and used in accordance with the instructions, may cause harmful interference to radio communications. However, there is no guarantee that interference will not occur in a particular installation. If this equipment does cause harmful interference to radio or television reception, which can be determined by turning the equipment off and on, the user is encouraged to try to correct the interference by one of the following measures:

- Reorient or relocate the receiving antenna.
- Increase the separation between the equipment and receiver.
- Connect the equipment into an outlet on a circuit different from that to which the receiver is connected.
- Consult the dealer or an experienced radio/TV technician for help.

TX

FCC ID: 2A2UNRTX4C00

IC: 24025-RTX4C00

This device complies with Industry Canada license-exempt RSS standard(s). Operation is subject to the following two conditions: (1) This device may not cause interference, and (2) this device must accept any interference, including interference that may cause undesired operations of this device.

WARNING: Any changes or modifications not expressly approved by the party responsible for compliance could void the user's authority to operate this equipment.

WARNING: While operating the Radio, a separation distance of at least 20 centimeters must be maintained between the radiating antenna and the body of the user or nearby persons in order to meet the FCC RF exposure guidelines.

AFHDS (automatic frequency hopping digital system)

AFHDS was developed for Radio control models and offers active and passive anti-jamming capabilities, low power consumption and high receiver sensitivity.

This radio system works in the frequency range of 2.405 to 2.475GHz. This band has been divided into 141 independent channels. Each radio system uses 16 different channels and 142 different types of hopping algorithm. By using various switch-on times, hopping scheme, and channel frequencies, the system is less likely to lose transmission.

Each transmitter has a unique ID. When binding with a receiver, the receiver saves that unique ID and can accept only data from that unique transmitter.

This avoids picking another transmitter signal and dramatically increases interference immunity and safety.

WARNING: Even with the AFHDS 2A-BS technology, if the radio system is not used in accordance with this manual, it can still fail and cause serious injury. Be sure to read and understand this entire manual, as well as the manual that came with all other RC components you are using.



Specifications

TRANSMITTER SPECS.	
Number of Channels	4
Use	Surface use only
RF	2.4GHz ISM
Maximum Power	<20dBm (e.i.r.p.) (EU)
2.4GHz Protocol	2A-BS
Distance	>300m (Ground Distance w/o Interference)
Channel Resolution	1024
Input Power	(4x)1.5AA batteries
Low Voltage Alarm	<4.2V
Antenna	Built-in
Temperature Range	-10deg. Celsius ~ +60deg. Celsius
Humidity Range	20% ~ 95%
Dimensions	160*193*97mm
Weight	220g
Certifications	CE, FCC ID: N4ZG4P00

ESC/RECEIVER SPECS.	
Number of Channels	3
Compatible Models	1:18 Crawler
RF	2.4GHz ISM
2.4GHz Protocol	2A-BS
Distance	≥ 300m (Ground Distance w/o Interference)
Input Power	2S LiPo
BEC Output	5V/1A
Data Interface	PWM
Cont. / Peak Current	10A/40A
Applicable Motors	180 Brushed Motor
Temperature Range	-10deg. Celsius ~ +60deg. Celsius
Humidity Range	20% ~ 95%
Weight	9.8g
Dimensions	38*25*13mm
Dimensions	38*25*13mm
Certifications	CE, FCC ID: 2A2UNR3A00

Transmitter Overview

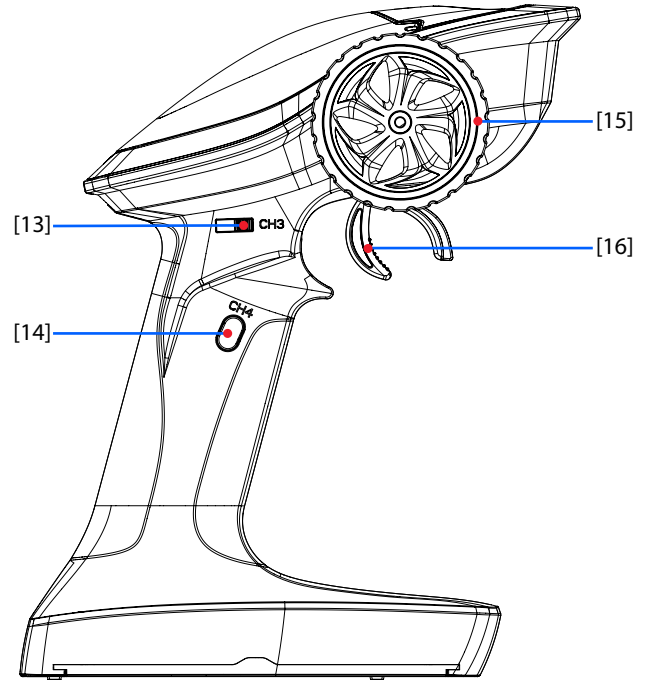
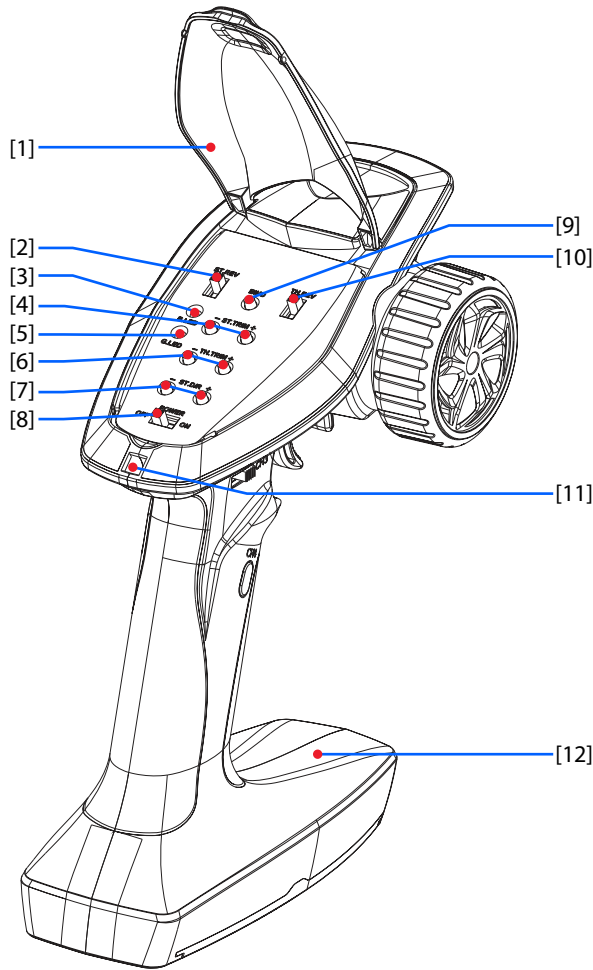

Location	Description	Location	Description
[1] Cover	Flip up panel cover	[10] "TH.REV"	Throttle reverse switch (PG.2)
[2] "ST.REV"	Steering channel reverse switch (PG.2)	[11] Lanyard Eye	Insert wrist lanyard (sold separately)
[3] "R.LED"	Power indicator LED	[12] Base	Battery compartment (4x AA batteries) (PG.1)
[4] "ST.TRIM"	Steering trim button (PG.2)	[13] "CH3"	Three-position switch
[5] "G.LED"	Status indicator LED	[14] "CH4"	Button (Not used)
[6] "TH.TRIM"	Throttle trim (PG.2)	[15] Steering Wheel	The maximum rotation of the steering wheel is 35 Degrees from center to full left or to full right (CH1)
[7] "ST.D/R"	Steering dual rates button (PG.2)	[16] Throttle Trigger	The total moving angle of the throttle trigger is 37.5 Degrees; 25 Degrees forward and 12.5 Degrees backward (CH2)
[8] "ON/OFF"	Power switch (PG.1)		
[9] "BIND"	BIND button (PG.7)		

Receiver/ESC Overview

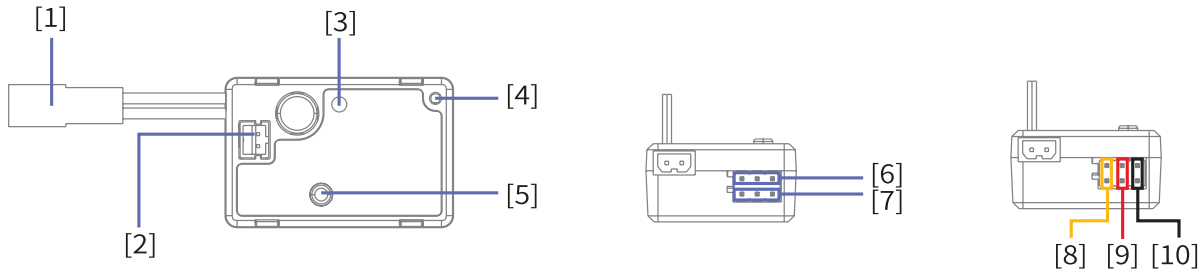

[1] Battery Plug (uses JST connector)	[6] CH1 Interface (Steering Servo)
[2] Motor Plug (includes extension w/ 2 blade connectors)	[7] CH3 Interface (Aux. Servo)
[3] LED	[8] S (Channel Interface Signal Pin)
[4] Antenna	[9] + (Channel Interface Anode Pin)
[5] Power Button	[10] - (Channel Interface Cathode Pin)

LED

The LED [3] indicates the working state of the receiver/ESC.

OFF: The receiver is not powered on.

ON - Solid: The receiver is on and working normally.

Flashing Quickly: The receiver is in binding mode.

Flashing Slowly: The transmitter is powered off, or the receiver isn't receiving a signal from the transmitter.

Interface

CH1 and CH3 channel interfaces [6] & [7] are standard 2.54mm*3 Pin connectors, which are found on most common servos.

The battery interface [1] uses a female JST connector. The battery pack must have a male JST connector.

The motor interface [2] includes a female PH2.0 connector that is built into the receiver/ESC. The included extension uses a male PH2.0 connector on one end and two blade connectors on the other end that connect to the positive and negative terminals found on the motor.

External Antenna

CAUTION: Do not pull on or bend the receiver's antenna. Do not fasten the antenna and the servo cable together.

CAUTION: Keep the receiver's antenna at least 1cm away from conductive materials such as carbon or metal. If the antenna is too close to conductive materials, it will negatively effect the signal strength of the receiver.

Receiver/ESC Connections



Receiver/ESC Connections - Side View

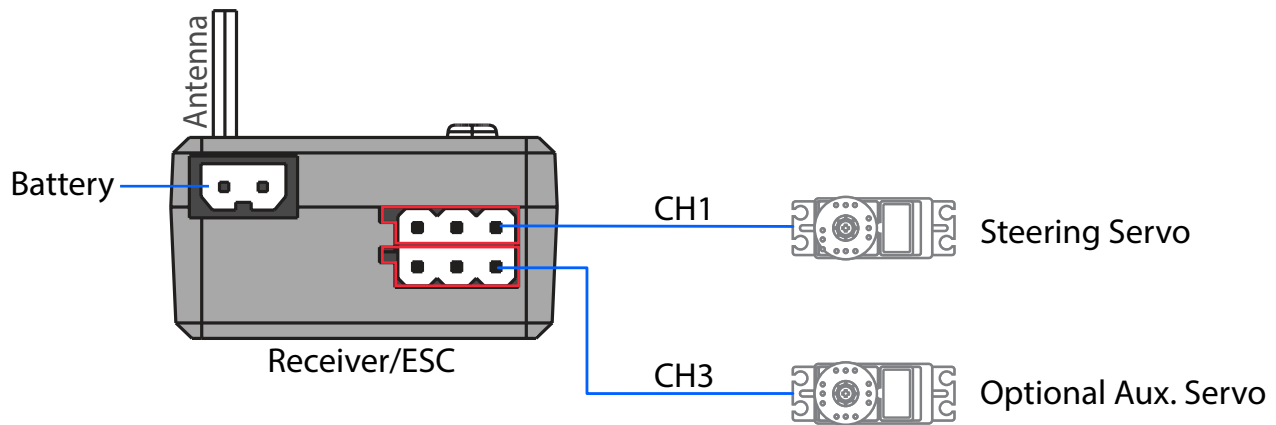

Attention!

Be sure all connections are plugged in correctly. Be sure all connectors are securely plugged in all the way.

The ESC and the receiver are both housed into a single unit so there is no need to plug in an external ESC. There are two 2.54mm 3 pin standard outlets (CH1 & CH3). These outlets are for plugging in a steering servo (CH1) and an optional auxiliary servo (CH3). Do not attempt to plug an ESC into either of these outlets. The ESC is already built into the receiver and no external ESC is needed. See the above illustrations for proper connections.

Pay attention to the following when installing the receiver:

1. Make sure the receiver is not installed near a motor or other sources of electrical noise.
2. Keep the receiver's antenna away from conductive materials such as carbon or metal. To ensure normal function, make sure there is a gap of at least 1cm between the antenna and the conductive material.

Powering ON

Follow the steps below to turn on the transmitter:

1. Check to make sure that the battery is fully charged and installed correctly.
2. Toggle the Power Switch to the ON position, and the R.LED will be solid on.
3. Power on the receiver.

Note: For safety always power on the transmitter before the receiver.

Binding

The transmitter and receiver have already been bound at the factory. However if the receiver needs to be replaced or additional receivers bound follow these steps:

1. Turn on the transmitter while pressing and holding the BIND button, then the transmitter will enter the binding mode. At this time, the G.LED will start flashing quickly. Once in binding mode release the Bind button.
2. The receiver will enter the binding mode automatically when powered on.
3. Once binding is successful, the LED of the receiver will flash slowly, and the transmitter LED will remain solid on after being re-powered on.

Note: When binding, put the transmitter into binding mode first, then the receiver.

Calibration

Use this function to correct for the mechanical deviation of the throttle trigger and steering wheel, for example, deviation occurred in the self-centering or maximum minimum travel, the steps are as following:

1. Turn and hold the steering wheel clockwise to the max travel and push the throttle trigger forwards as far as possible, and at the same time turn on the transmitter, the transmitter will be in calibration mode. The R.LED and G.LED will work in two-flashing-one-off state repeatedly.
2. Steering Wheel Calibration: Turn the steering wheel to the max and min travel clockwise/counterclockwise respectively. When calibration is completed, the R.LED will be off.
3. Throttle Trigger Calibration: Push/pull the throttle trigger to forward/backward as far as it will go. When calibration is completed, the G.LED will be off.
4. Once calibration is complete, press the BIND button to save and exit. The G.LED will be lit solid.

Powering OFF

1. Unplug the battery pack from the receiver and remove it from the vehicle.
2. Turn off the transmitter.

Note: Always be sure to disconnect the battery pack from the receiver BEFORE turning off the transmitter.

Channel Reverse

This function is used to adjust each channel's direction of movement in relation to its input.

The ST.REV and TH.REV are the reverse switches for CH1 (steering) and CH2 (throttle). If the switch is up, it indicates the channel is in reverse, and if the switch is down, it indicates the channel is in its normal operating mode. Example: If the vehicle moves forward while moving the throttle trigger to reverse, flip the TH.REV switch. Refer to PG.3 of this manual for more information.

Steering & Throttle Trims

1. The ST.TRIM+ and ST.TRIM- are the trim buttons for centering CH1 (steering), and can be multiplexed as trims of CH3 and CH4. For multiplexing switching mode, refer to PG.8 " Mode Switching".
2. TH.TRIM+ and TH.TRIM- are the trim buttons for centering CH2 (throttle). Adjustment Range: -120us - + 120us, and the step is 4us. Refer to PG.3 of this manual for more information on setting trims.

LED status:

- When pressing the trim keys, the G.LED will flash slowly on short presses and quickly on long presses.
- When the trim adjustment value is at the neutral position, the G.LED will flash twice slowly.
- When the trim adjustment value is at it maximum or minimum setting, the G.LED will not flash at all.

Note: After the throttle trim is changed, the receiver needs to be re-powered on to recognize the new throttle neutral. Otherwise, an exception may occur during vehicle reversing.

Steering Dual Rate

ST.D/R+ and ST.D/R- are used for the CH1 steering servo travel adjustment, which can be multiplexed as CH2 (throttle), CH3, and CH4 servo travel adjustment, refer to "Mode Switching" for multiplex switching mode; Adjustment Range: 0-120%(the default is 100%), and the step is 5%.

ST.D/R+: Increases servo travel.

ST.D/R-: Decreases servo travel.

LED status:

- When using the D/R keys, the G.LED will flash slowly on short presses and quickly on long presses.
- When the travel adjustment value is at its end points (maximum/minimum values of 0/120%), the G.LED will not flash at all.

Refer to PG.3 of this manual for more information.

Mode Switching

This function is for reusing ST.TRIM(including ST.TRIM+ and ST.TRIM-) and ST.D/R (including ST.D/R+ and ST.D/R-) adjustment buttons for different channels. Refer to [Steering Trims] and [Steering Dual Rates.

Setup: While the receiver is ON, quickly press the BIND button twice (within 1 second) to cycle through modes 1, 2, 3, and 4. The default setting when powering on is mode 1.

Mode 1: The G.LED flashes slowly once. The ST.TRIM is used for CH1 trim adjustments and the ST.D/R is used for CH1 end point adjustments.

Mode 2: The G.LED flashes twice slowly. The ST.TRIM is used for CH1 trim adjustments and the ST.D/R is used for CH2 end point adjustments.

Mode 3: The G.LED flashes three times slowly. The ST.TRIM is used for CH3 trim adjustments and the ST.D/R is used for CH3 end point adjustments.

Mode 4: The G.LED flashes slowly four times. The ST.TRIM is used for CH4 trim adjustments and the ST.D/R is used for CH4 end point adjustments.

Calibration

Use this function to correct for the mechanical deviation of the throttle trigger and steering wheel, for example, deviation occurred in the self-centering or maximum minimum travel, the steps are as following:

1. Turn and hold the steering wheel clockwise to its maximum travel and push the throttle trigger forward as far as possible, and at the same time turn on the transmitter. This puts the transmitter into calibration mode. The R.LED and G.LED will both repeat the sequence of "flashing twice-off-flashing twice".
2. Steering Wheel Calibration: Turn the steering wheel to its maximum left and right position, back and forth. When calibration is completed, the R.LED will be off.
3. Throttle Trigger Calibration: Push/pull the throttle trigger to forward/backward as far as it will go. When calibration is completed, the G.LED will be off.
4. Once calibration is complete, press the BIND button to save and exit. The G.LED will be lit solid.

Failsafe

The failsafe function is used to protect the model and surrounding people when the connection fails between the receiver and transmitter. The failsafe is activated when the transmitter is turned off, the transmitter batteries die, or if there is interference. By default, CH2 is the only channel with a failsafe setting. The other channels are not set.

- The failsafe for CH2 is enabled by default and the ESC will enter the braking state when the failsafe is activated.
- For the other channels, the interfaces will maintain the last output when the failsafe is activated.

Setting the failsafe:

1. With the transmitter and ESC both turned ON, hold the control corresponding to the channel at the desired failsafe position.
2. Then press and hold the BIND button for 3 seconds. The G.LED will flash for 2 seconds, indicating that the failsafe setting was saved successfully.

Beginner Mode

Beginner mode is designed for people who are new to the hobby.

In this mode, throttle output is limited to 50 percent and the channel range by default is set to 1250~1500~1750us.

Setup:

To switch between beginner mode and normal mode, press and hold the CH4 button while turning the steering wheel counterclockwise as far as it will go. While holding, power on the transmitter. The G.LED will flash in a sequence of "flash-flash-off, flash-flash-off", indicating beginner mode is activated.

Note: By default, the system is set to normal mode each time it is turned on .

Low Voltage Protection & Overheating Protection

This receiver has a low voltage protection function.

- Low Voltage Protection: When the battery voltage is detected to be lower than the safe operating range, power output to all channels will be cutoff.

This receiver/ESC also has an overheat protection function that will cutoff power to CH2 when activated. Once the receiver/ESC cools down to normal operating temperature, CH2 will resume to it's normal operating power output.

Note: In the event there is a blockage in the drive train, the receiver/ESC will cutoff power to the motor (CH2) to prevent damage to both the receiver/ESC unit and the motor. If this happens, inspect the vehicle and clear out anything that may be obstructing the drive-train from spinning freely. This may include lodged sticks, rocks, or anything else binding the drive-train.

Troubleshooting

TROUBLE	POSSIBLE CAUSE	POSSIBLE SOLUTIONS
The ESC will not power on.	<ol style="list-style-type: none"> 1. There isn't a battery plugged into the ESC. 2. The LIPO battery being used isn't charged. 	<ol style="list-style-type: none"> 1. Plug a fully charged LIPO battery into the ESC and try again. (PG.1) 2. Contact Redcat support.
The vehicle ran backward when you pulled the throttle trigger towards you.	<ol style="list-style-type: none"> 1. The radio "Throttle Reverse" switch may be improperly set. 2. The motor wiring is incorrect. 	<ol style="list-style-type: none"> 1. Switch the radio "Throttle Reverse" switch. (PG.2) 2. Be sure the motor is plugged in correctly. The red wire plugs into the tab labelled (+) on the motor .
Vehicle moves with no throttle input.	<ol style="list-style-type: none"> 1. Throttle trim is not set properly. 2. The transmitter needs to be calibrated. 	<ol style="list-style-type: none"> 1. Set transmitter throttle trim. (PG.2) 2. Calibrate the transmitter. (PG.7)
The motor suddenly stops working.	<ol style="list-style-type: none"> 1. Transmitter signal is lost 2. The battery pack needs charging or the thermal protection may have been activated. 	<ol style="list-style-type: none"> 1. Be sure the transmitter has good batteries and is turned on. 2. Check the battery voltage and the ESC temperature. Let cool and recharge battery. (PG.9)
The receiver/ESC is powered on, but nothing works and the LED on the receiver/ESC is blinking slowly.	<ol style="list-style-type: none"> 1. The receiver isn't picking up the transmitter signal. 	<ol style="list-style-type: none"> 1. Be sure the transmitter is turned on. 2. Put new batteries in the transmitter. (PG.1) 3. BIND the transmitter to the receiver/ESC
The receiver/ESC is powered on, but nothing works and the LED on the receiver/ESC is blinking quickly.	<ol style="list-style-type: none"> 1. The receiver is in BIND mode. 	<ol style="list-style-type: none"> 1. Be sure the transmitter is turned on and power on the receiver/ESC again. (PG.1)
Clicking noise while steering.	<ol style="list-style-type: none"> 1. The servo horn is stripped. 2. The servo gears are stripped. 	<ol style="list-style-type: none"> 1. Replace the servo horn. 2. Replace the servo.
Vehicle won't steer or move.	<ol style="list-style-type: none"> 1. Battery pack not charged. 2. Battery wires loose. 3. Did not follow proper start-up instructions. 	<ol style="list-style-type: none"> 1. Charge the battery pack. 2. Plug in the battery securely. 3. Follow the start-up sequence on PG.1.
Vehicle turns to the side automatically.	<ol style="list-style-type: none"> 1. Steering trim needs adjusting. 2. Steering servo horn needs realigning or replaced. 3. Servo gears are stripped. 	<ol style="list-style-type: none"> 1. Adjust transmitter steering trim. (PG.2) 2. Check servo horn, replace if worn or stripped. 3. Replace the servo.
Vehicle steers to the left when you steer to the right.	<ol style="list-style-type: none"> 1. Steering reverse (on transmitter) is set incorrectly. 2. You are driving towards yourself and it just seems like it's backwards. 	<ol style="list-style-type: none"> 1. Set the steering reverse on transmitter. (PG.2) 2. Practice driving the vehicle to get used to steering with different vehicle orientations. When driving towards yourself, it just seems like the steering is backwards.

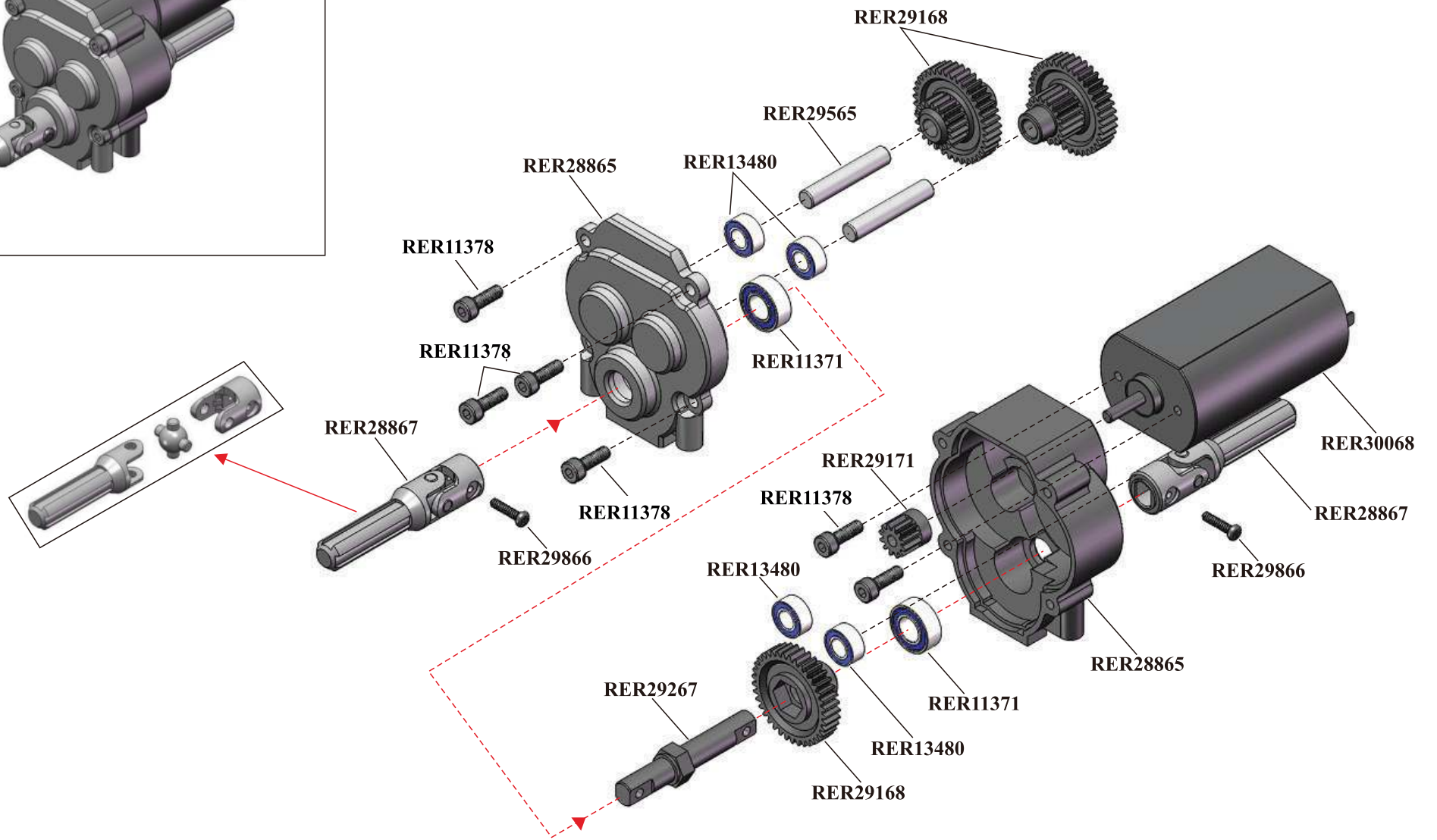

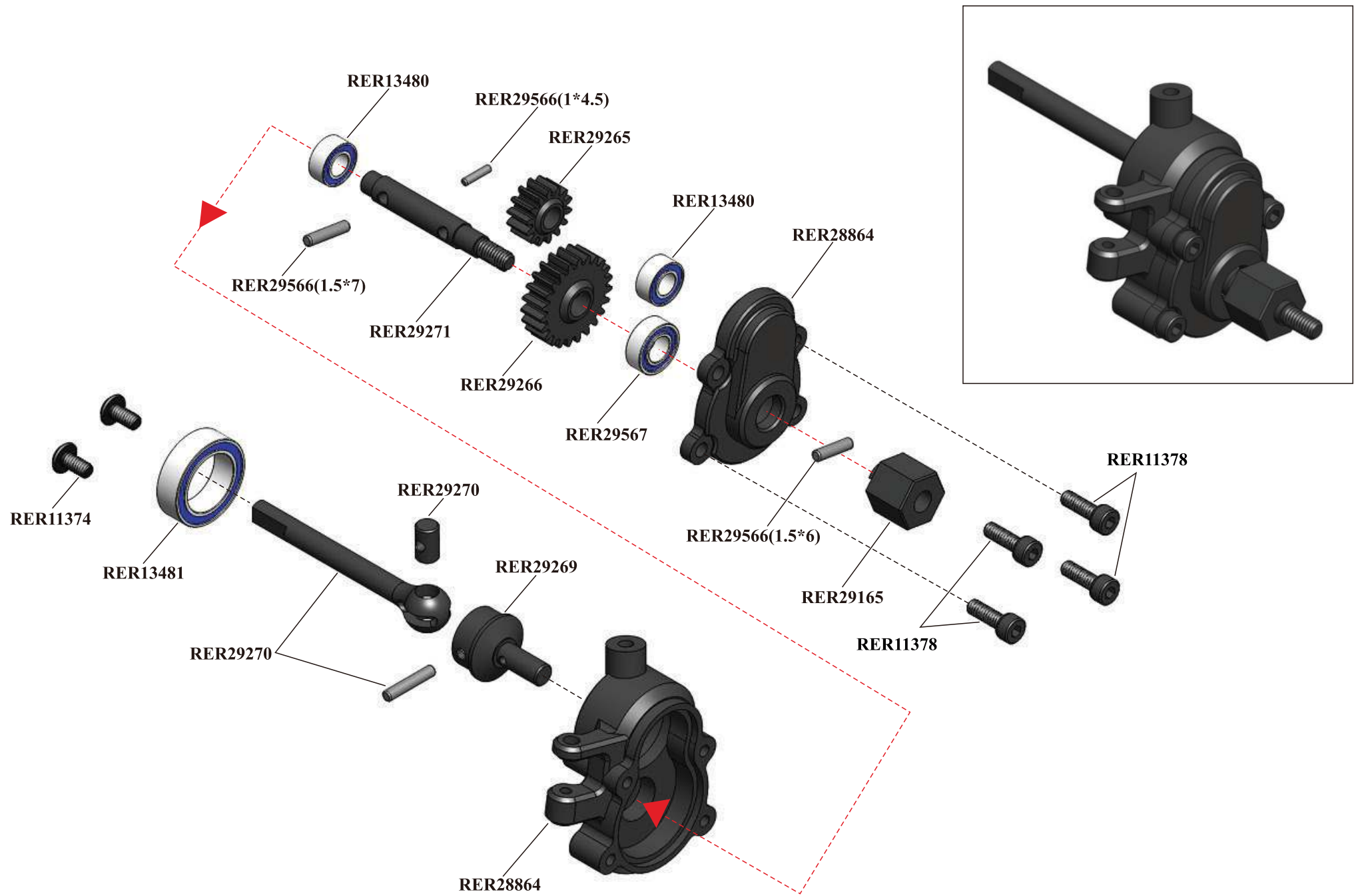

Front Axle Assembly

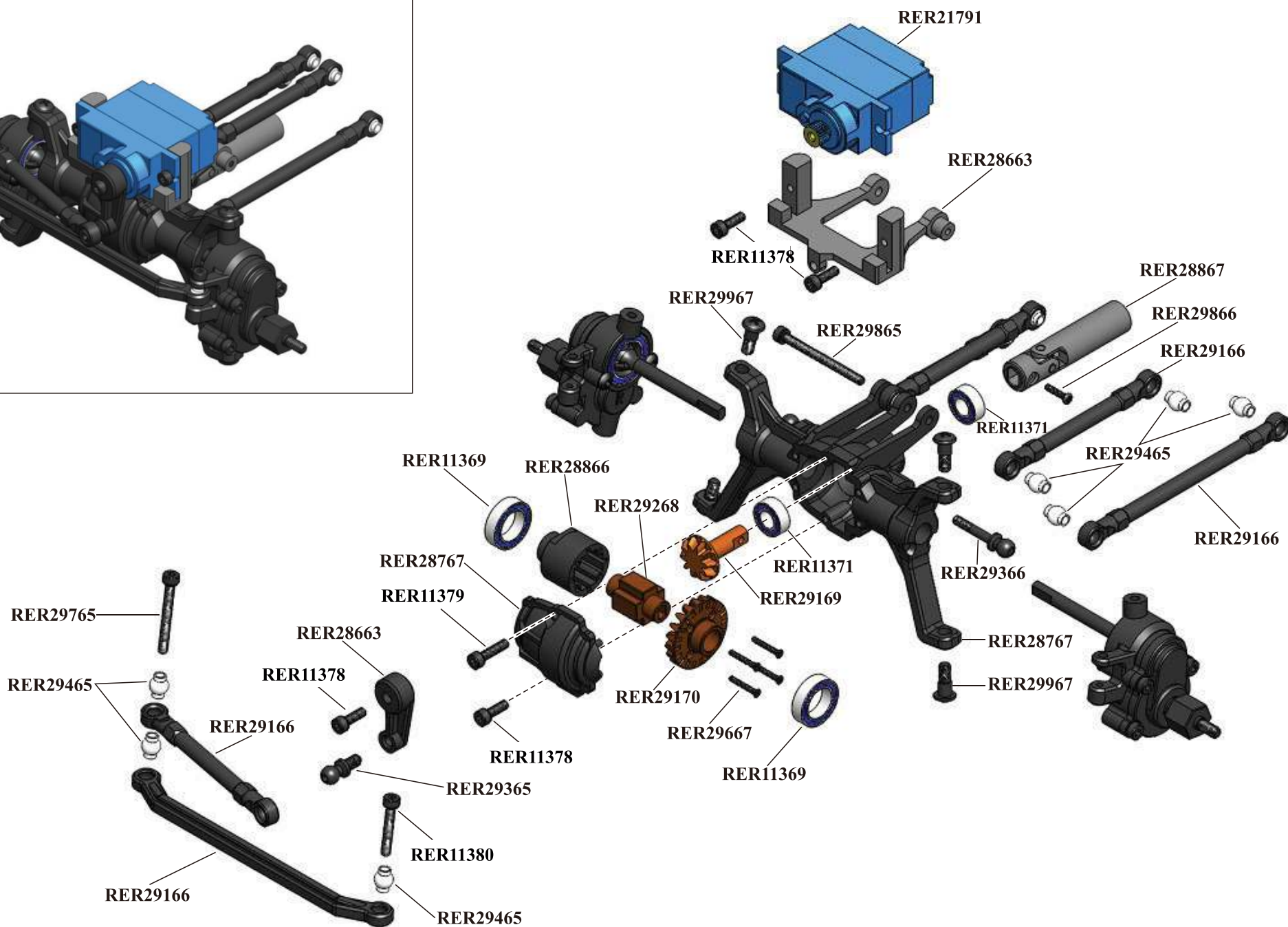

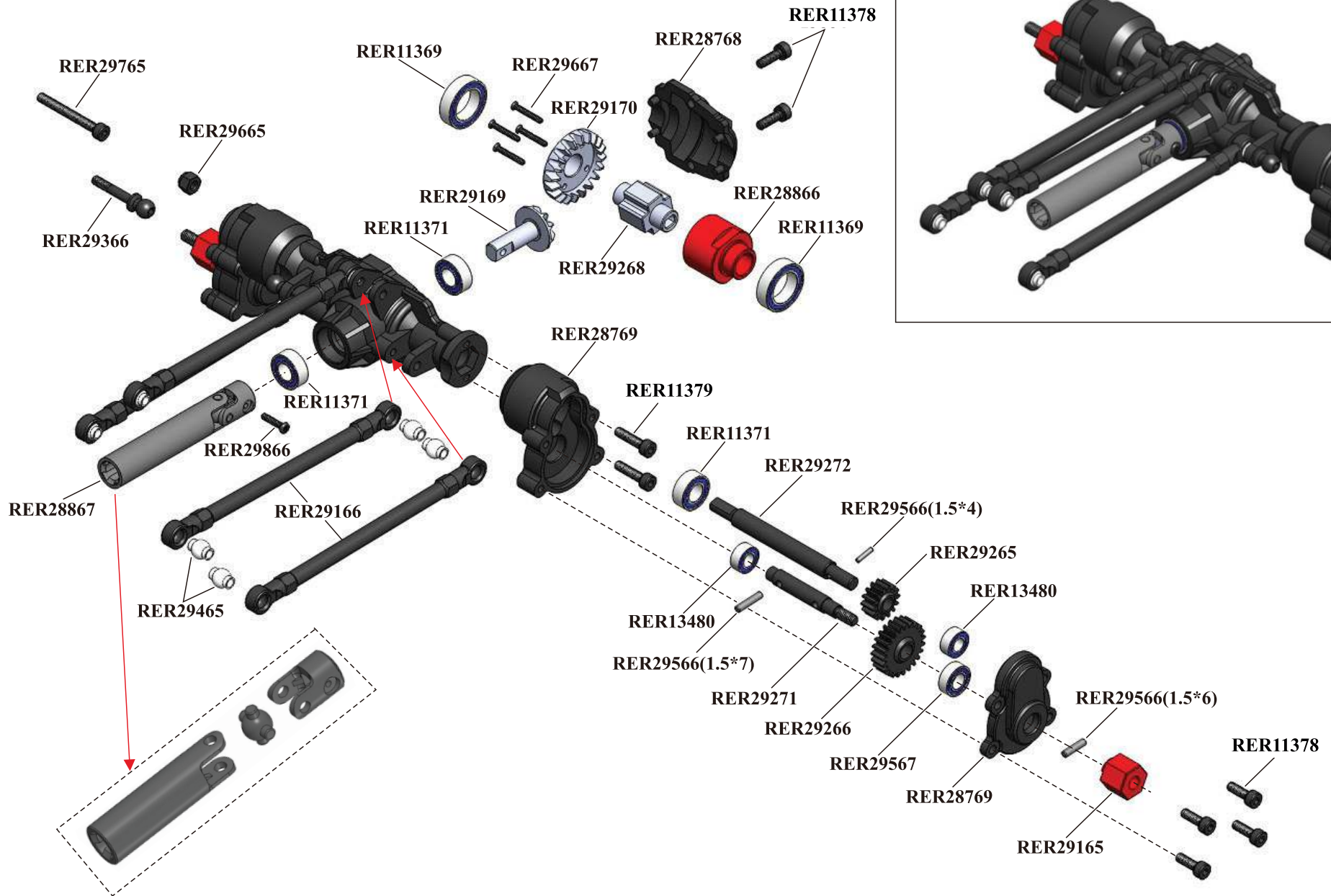

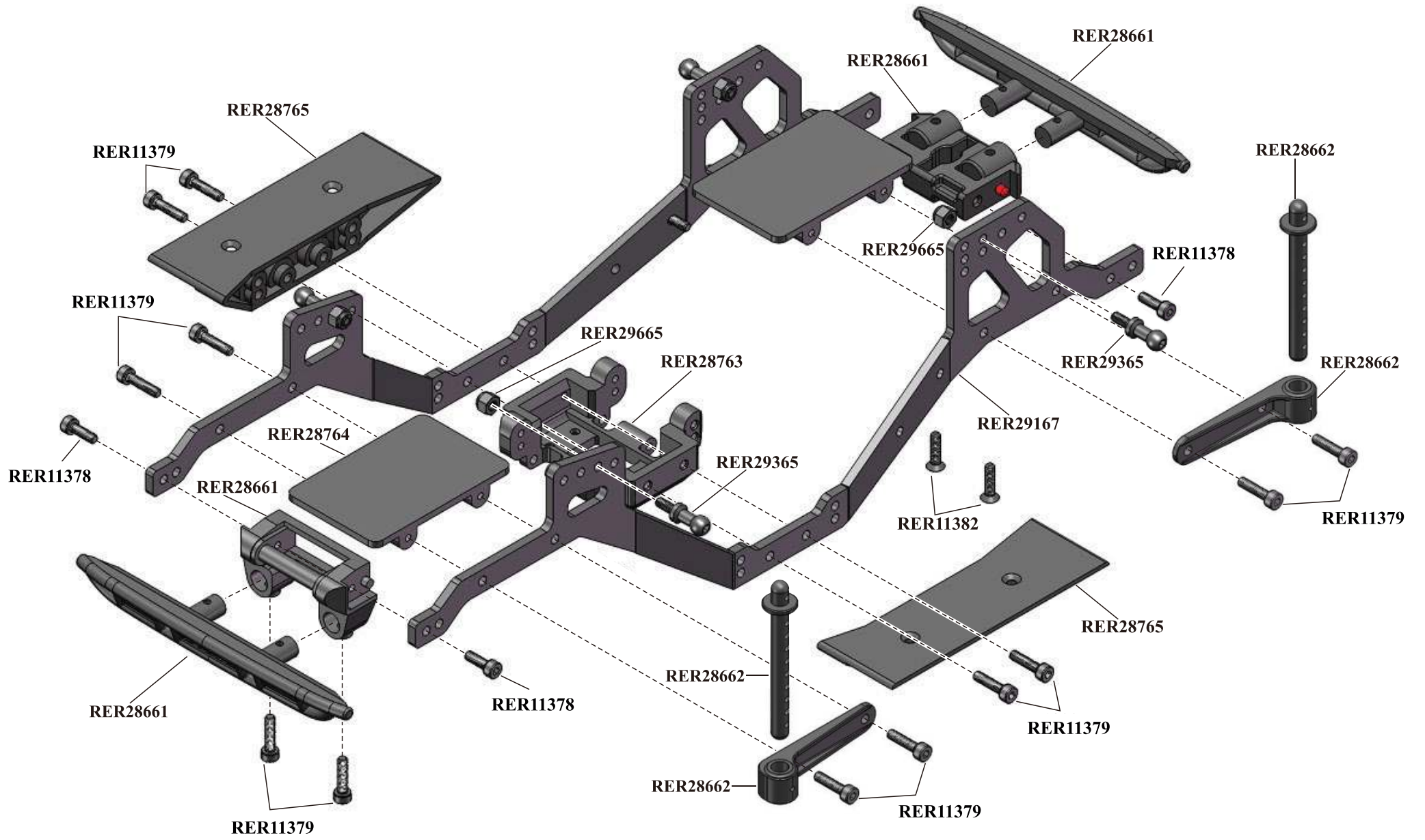

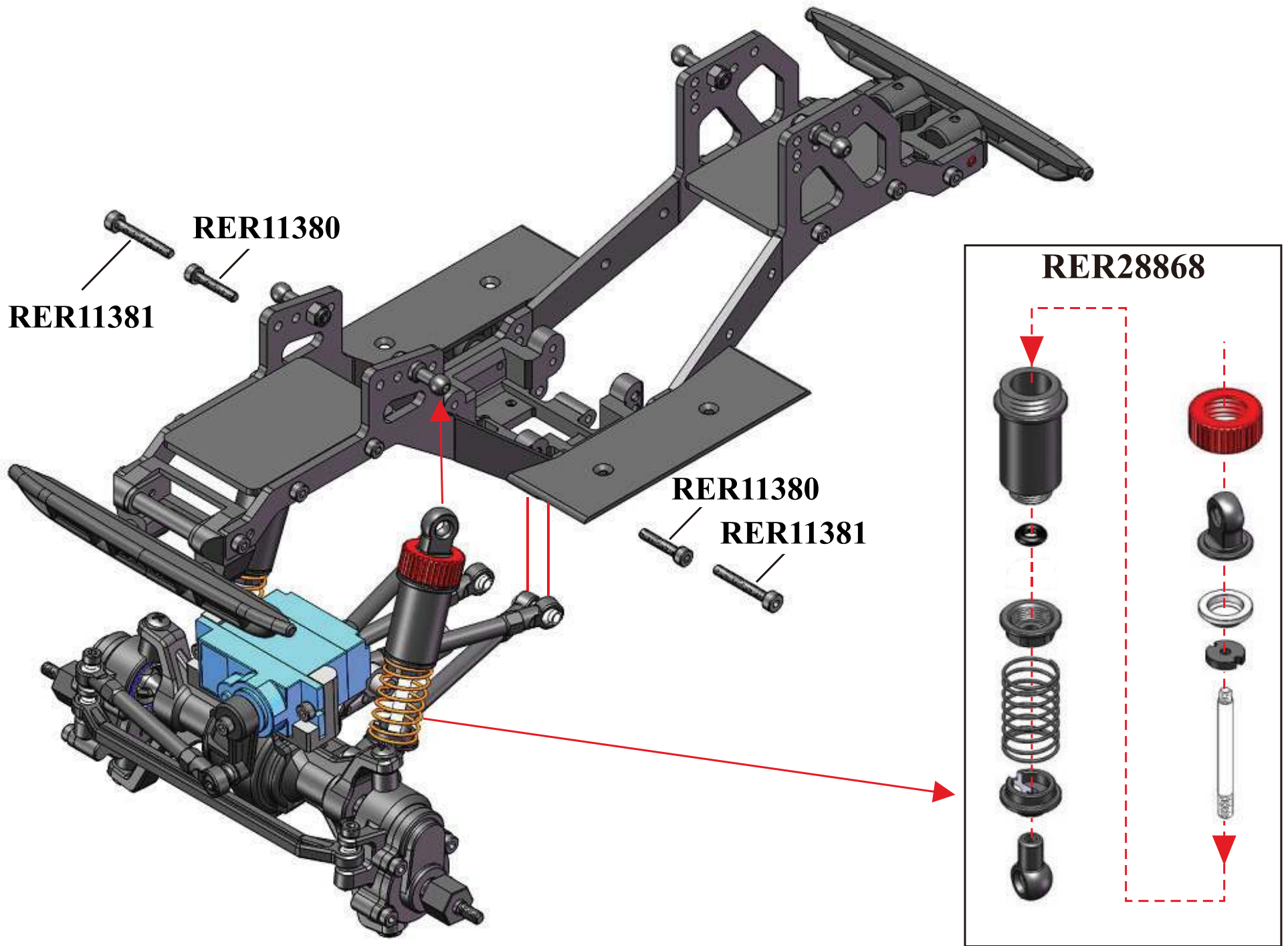

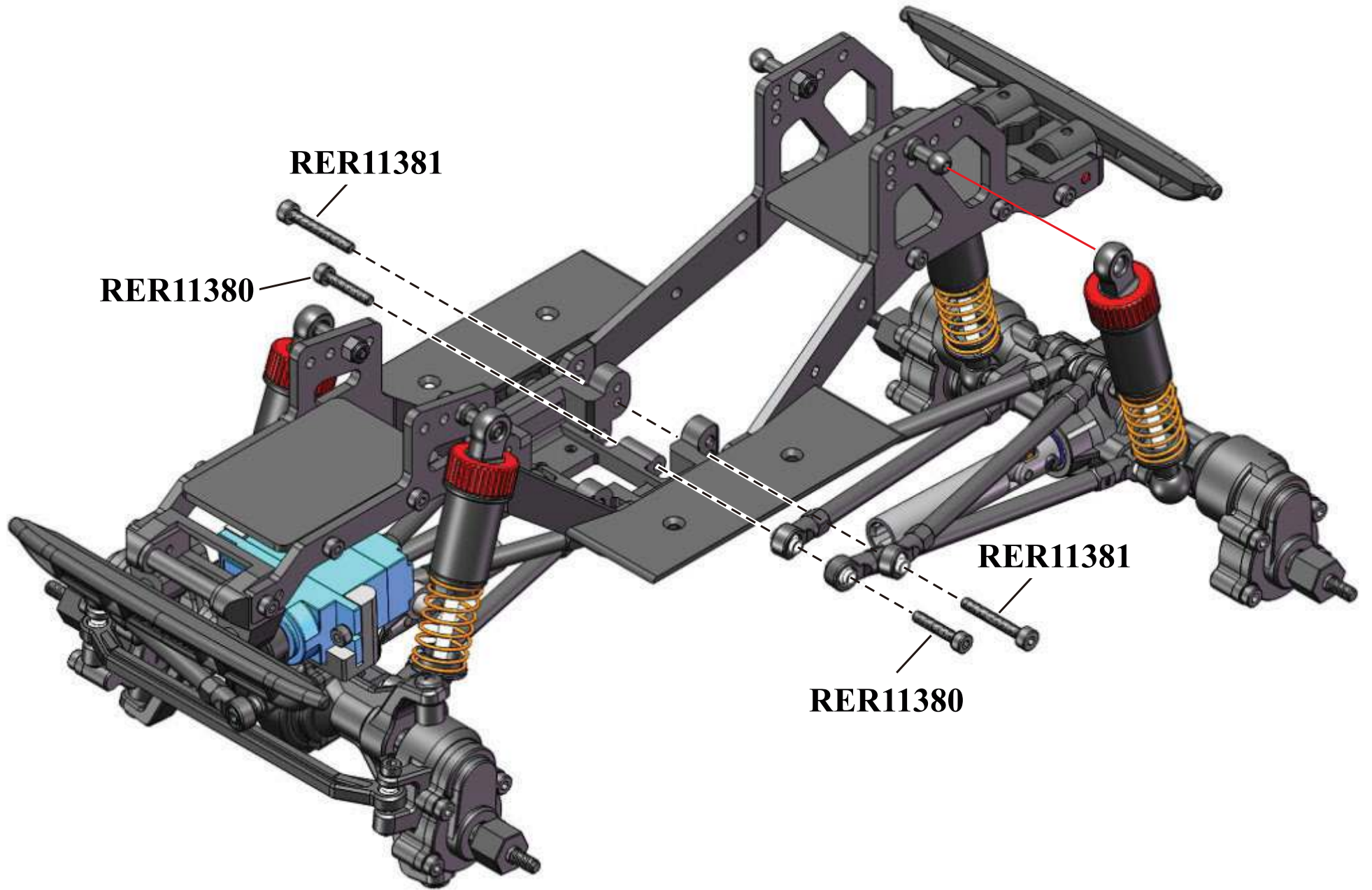

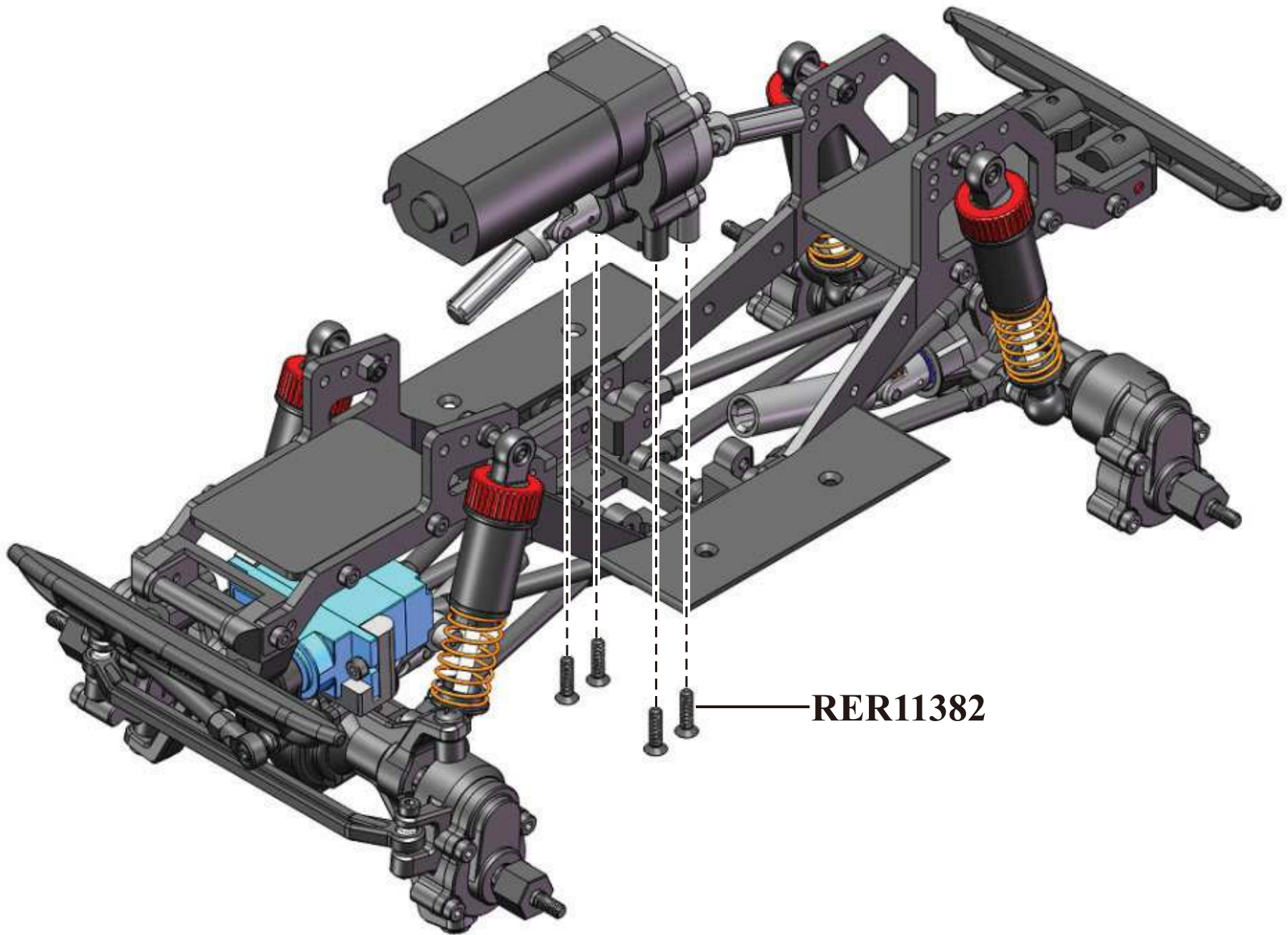

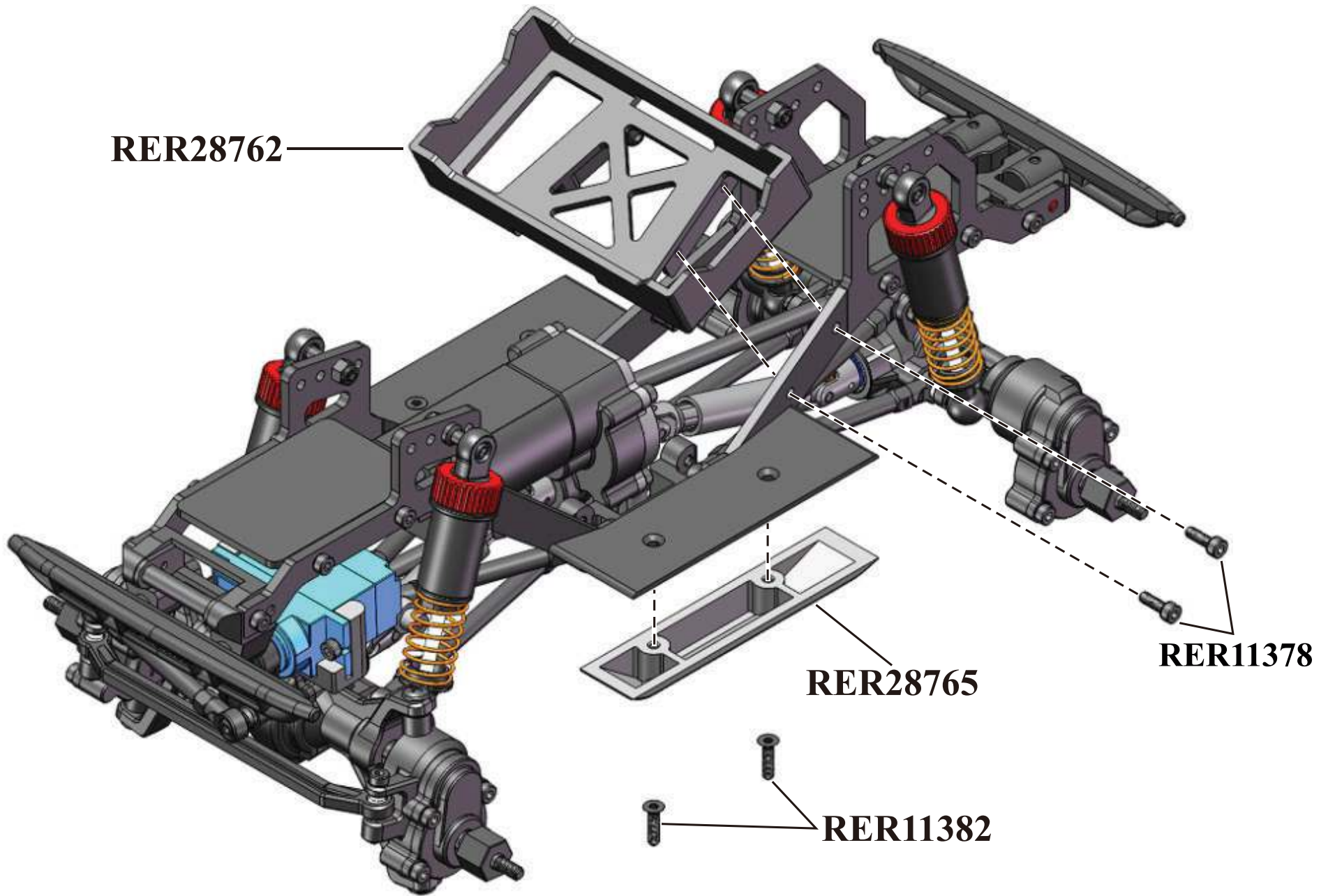

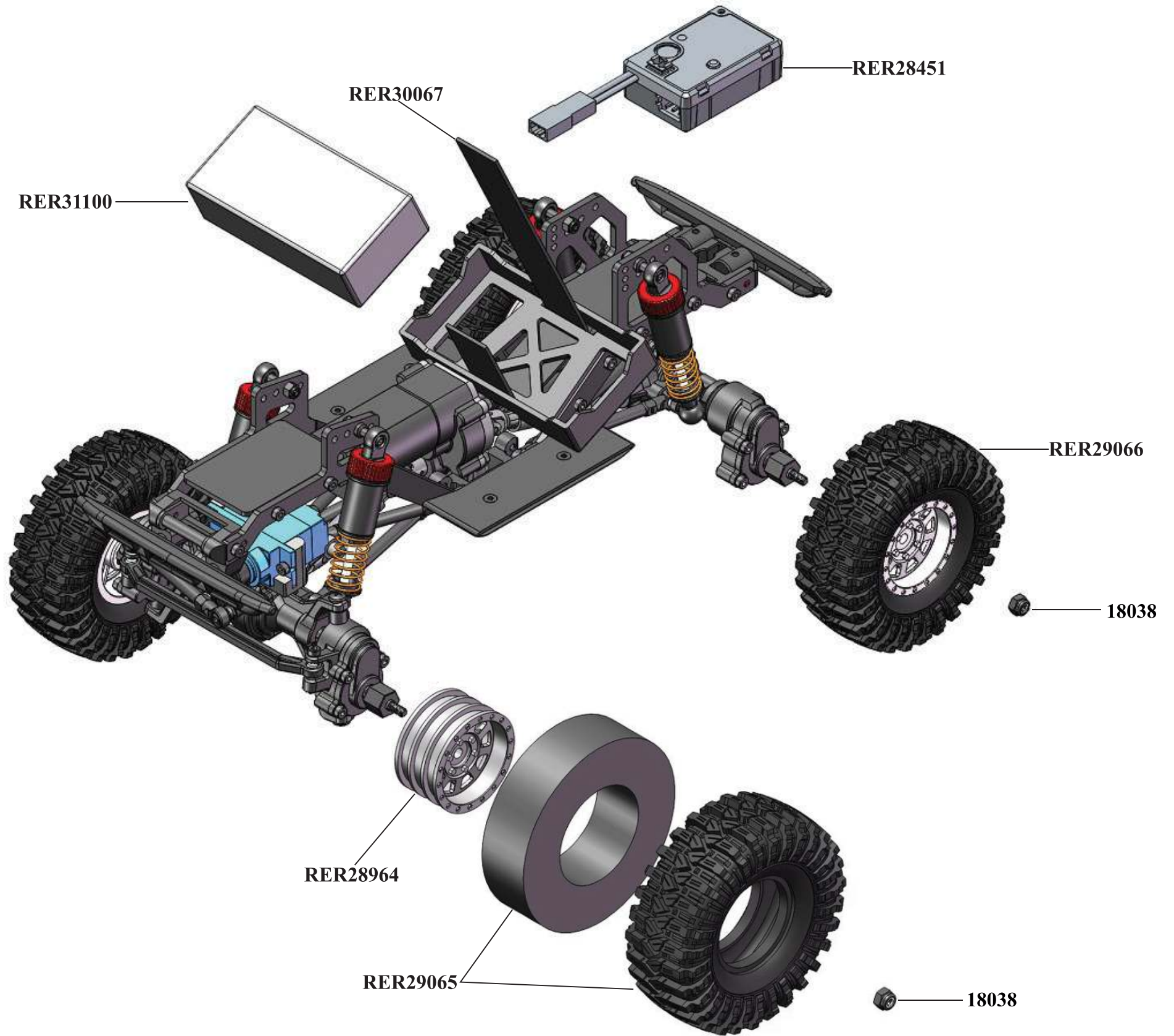

RER29968-(Red)
RER29969-(Blue)
RER29970-(Gray)
RER29971-(Clear)

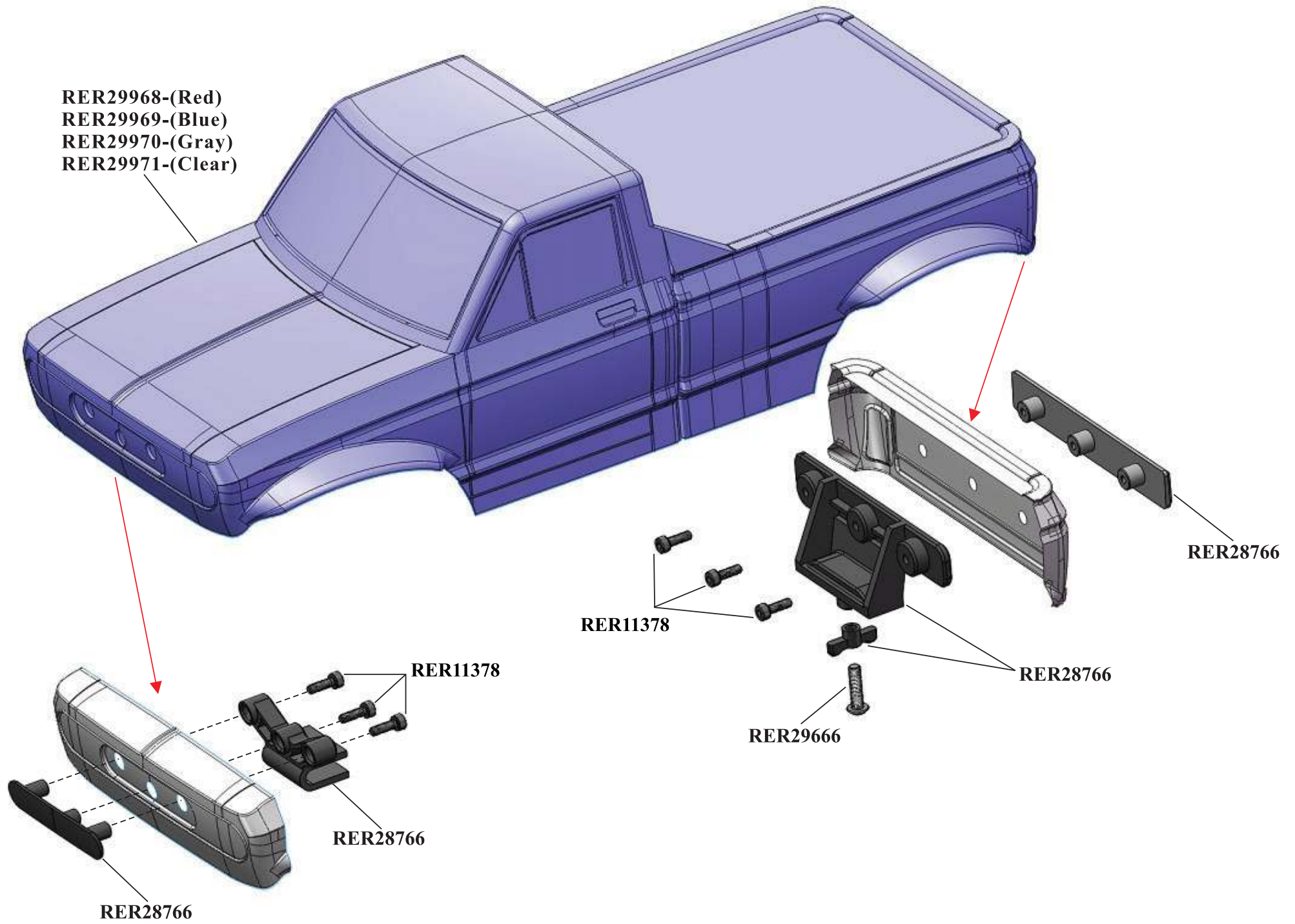

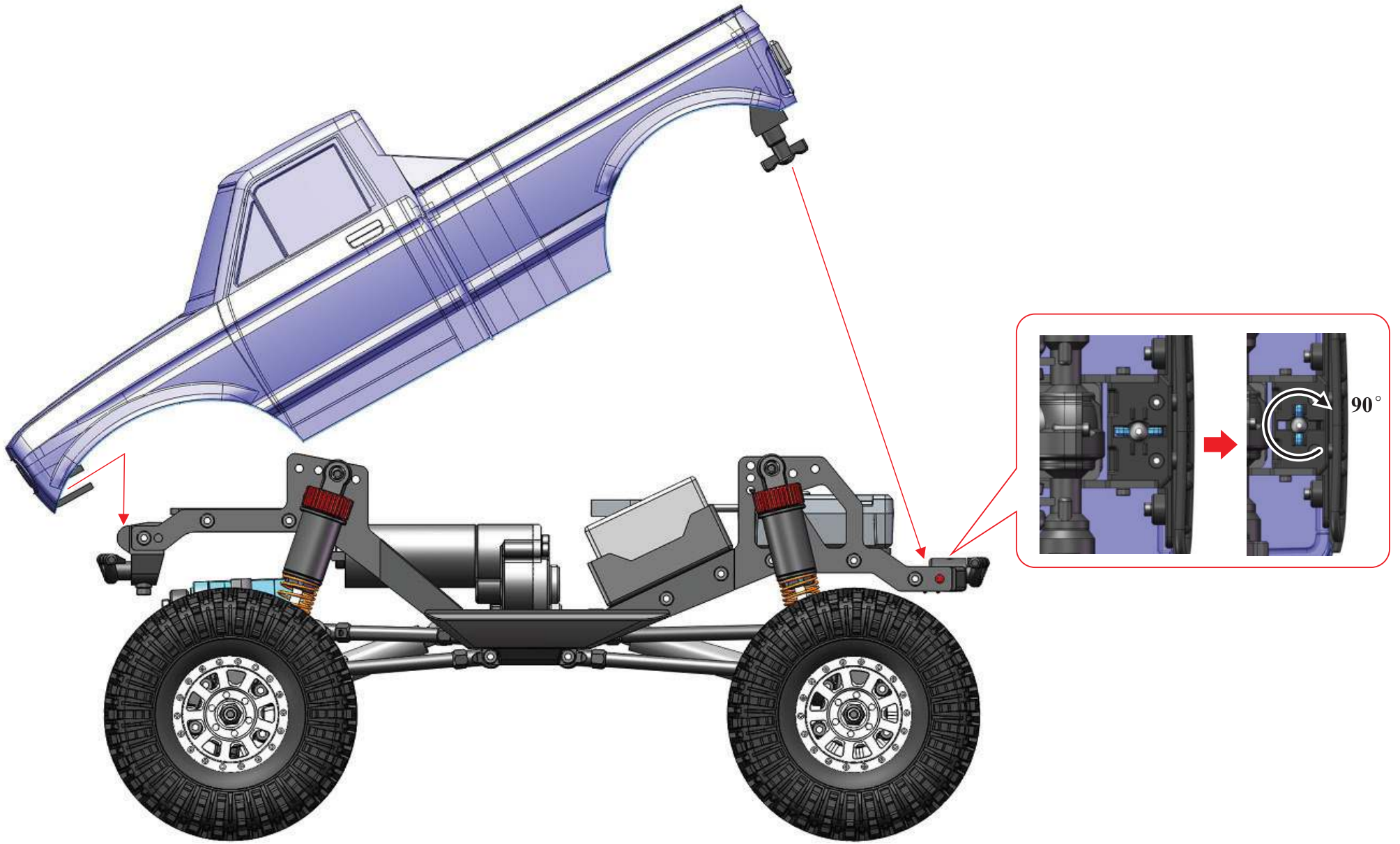





Ascent-18 Parts List

Spare Parts

RER28661-F/R Bumper Set w/Mounts(Plastic)(1Set) 	RER28662-Body Posts (Plastic)(1set) 	RER28663-Servo Mount w/ Horn(Plastic)(1set) 	RER28762-Battery Case (1pc) 	RER28763-Center Skid Plate(1pc) 
RER28764-ESC Mount (2pc) 	RER28765-Side Plate Set (1set) 	RER28766-Body Mount Hinge Set(1set) 	RER28767-Front Axle Housing (Plastic)(1pc) 	RER28768-Rear Axle Housing (Plastic)(1pc) 
RER28769-Rear Outer Portal Housing (1set) 	RER28864-Front Outer Portal Housing Set(Plastic)(1set) 	RER28865-Transmission Housing (Plastic)(1set) 	RER28866-Diff Case(2pc) 	RER28867-Center Drive Shaft Set (1set) 
RER28868- Shock Set (4pcs) 	RER28964-Crawler Wheel (4pcs) 	RER29065-MT Mud Terrain Crawler Tires (1pr) 	RER29066-Pre-Mounted MT Mud Terrain Crawler Tires (1pr) 	RER29165-Wheel Hex (Plastic)(4pcs) 
RER29166- Link Set Complete (1set) 	RER29167-Frame Rails (1pr) 	RER29168-Gear Set (Plastic)(1set) 	RER29169-Diff Pinion (10T)(2pcs) 	
RER29170-Diff Ring Gears (20T)(2pcs) 	RER29171-Motor Pinion Gears (12T)(2pcs) 	RER29265-Portal Gear (14T)(4pcs) 	RER29266-Portal Gears (23T)(4pcs) 	RER29267-Transmission Gear Shaft (2pcs) 
RER29268-Diff Locker (2pcs) 	RER29269-CVA Axle (2pcs) 	RER29270-CVA Shafts w/ pins (1set)  1.5*8mm	RER29271-Wheel Shafts (4pcs) 	RER29272-Rear Axles (2pcs) 

























Ascent-18 Parts List

Spare Parts

<p>RER29365-Upper Shock Ball Stud (4pcs)</p> 	<p>RER29366-Lower Shock Ball Stud (4pcs)</p> 	<p>RER29465-Suspension Balls (4mm)(10pcs)</p> 	<p>RER29565-Transmission Pins (4pcs)</p> 	<p>RER29566-Drive Pin Set (15pcs)</p> 
<p>RER13481-8*12*3.5mm Rubber Sealed Ball Bearings(6pcs)</p> 	<p>RER13480-3*6*2.5mm Rubber Sealed Ball Bearings(6pcs)</p> 	<p>RER11369-7*11*3mm Rubber Sealed Ball Bearings(2pcs)</p> 	<p>RER29567-3.5*7*2.5mm Ball Bearings (6pcs)</p> 	<p>RER11371-4*8*3mm Rubber Sealed Ball Bearings(6pcs)</p> 
<p>18038 2.5mm Steel Nylon Insert Locknuts (8pcs)</p> 	<p>RER29665-2mm Locknuts (6pcs)</p> 	<p>RER11374-2*4mm Button Head Hex Machine Thread Screws (10pcs)</p> 	<p>RER29666-2.5*10mm Button Head Machine Thread Screws (10pcs)</p> 	<p>RER11382-2*8mm Countersunk Hex Machine Thread Screws(10pcs)</p> 
<p>RER29667-1.2*8mm Countersunk Hex Machine Thread Screws (8pcs)</p> 	<p>RER11378 - 2*6mm Cap Head Screw (10pcs)</p> 	<p>RER11379 - 2*8mm Cap Head Screw (10pcs)</p> 	<p>RER11380 - 2*10mm Cap Head Screw (10pcs)</p> 	<p>RER11381 - 2*14mm Cap Head Screw (10pcs)</p> 
<p>RER29765-2*17mm Cap Head Screws (8pcs)</p> 	<p>RER29865-2*23mm Cap Head Screws (5pcs)</p> 	<p>RER29866-1.4*6mm Round Head Self Tapping Screws (10pcs)</p> 	<p>RER29967-2.5*7mm Shoulder Button Head Machine Thread Screws (8pcs)</p> 	<p>RER30067 - Battery Strap (1pc)</p> 
<p>RER31100 - 750mAh 2S LIPO Battery Pack</p> 	<p>RER28451 - Redcat R3C-ER 2-in-1 ESC/RX</p> 	<p>RER21791 - Hexfly HX-M4K 4kg coreless metal gear micro servo</p> 	<p>RER30068 - 180 Motor</p> 	<p>Ascent-18 Crawler Body RER29968-(Red) (1pc) RER29969-(Blue) (1pc) RER29970-(Gray) (1pc) RER29971-(Clear) (1pc)</p> 

Ascent-18 Parts List

Hop Up Parts

<p>RER30175-Portal Box Outer with Machined Edge (Brass)(Black)(1pr)</p> 	<p>RER30176-Servo Holder (Brass)(Black)(1pc)</p> 	<p>RER30177-Servo Holder (Aluminum)(Red)(1pc)</p> 	<p>RER30178-Servo Holder (Aluminum)(Bronze Color)(1pc)</p> 	<p>RER30179-Diff Cover (Brass)(Black)(1pr)</p> 
<p>RER30180-Diff Cover (Aluminum)(Red)(1pr)</p> 	<p>RER30181-Diff Cover (Aluminum)(Bronze Color)(1pr)</p> 	<p>RER30279-Front Links (Brass) (Black) (4pcs)</p> 	<p>RER30280-Front Links (Aluminum) (Red) (4pcs)</p> 	<p>RER30281-Front Links (Aluminum) (Bronze Color) (4pcs)</p> 
<p>RER30282-Rear Links (Brass) (Black) (4pcs)</p> 	<p>RER30283-Rear Links (Aluminum) (Red) (4pcs)</p> 	<p>RER30284-Rear Links (Aluminum) (Bronze Color) (4pcs)</p> 	<p>RER30285-Steering Link (Brass)(Black)(1pc)</p> 	<p>RER30286-Steering Link (Aluminum)(Red)(1pc)</p> 
<p>RER30379-Steering Link (Aluminum)(Bronze Color)(1pc)</p> 	<p>RER30380-Wheel Hexes (Brass)(4pcs)</p> 	<p>RER30381-Shock Bodies (Aluminum)(Red)(4pcs)</p> 	<p>RER30382-Shock Bodies (Aluminum)(Bronze Color)(4pcs)</p> 	<p>RER30383-Center Skid Plate (Brass)(Black)(1pc)</p> 
<p>RER30384-Center Skid Plate (Aluminum)(Red)(1pc)</p> 	<p>RER30385-Center Skid Plate (Aluminum) (Bronze Color)(1pc)</p> 	<p>RER30386-Inner Portal Axle Box (Brass)(Black) (1set)</p> 	<p>RER30479-Servo Horn (Aluminum)(Bronze Color)(1pc)</p> 	<p>RER30480-Steel Transmission Gear Set (1set)</p> 



www.redcatracing.com

Follow us on social media

Take a photo, create a video, post and share your Redcat experience.

Stay up to date on the latest Redcat news, products, and creative content. While these profiles are not customer service channels, you might find that one of our subject experts or another member of the community is able to assist you. If you have an issue or need technical and or product support, please reach out to Redcat directly through our website.

 <https://www.facebook.com/RedcatRacing>

 <https://www.instagram.com/redcatracing/>

 <https://www.youtube.com/RedcatRacing>

 <https://twitter.com/RedcatRacing>

 <https://www.pinterest.com/redcatracing/>

 <https://www.tiktok.com/@redcatracing>

IMPORTANT LINKS:

- To view the full length manual with ESC guide, Radio guide, exploded views and parts lists, go to: www.redcatracing.com/pages/manuals
- Link to electric vehicles manual:
www.redcatracing.com/manuals/ELECTRIC-MANUAL.pdf

