

BE ORIGINAL



KRAKEN

NITRO 580 MANUAL



SAB HELI DIVISION

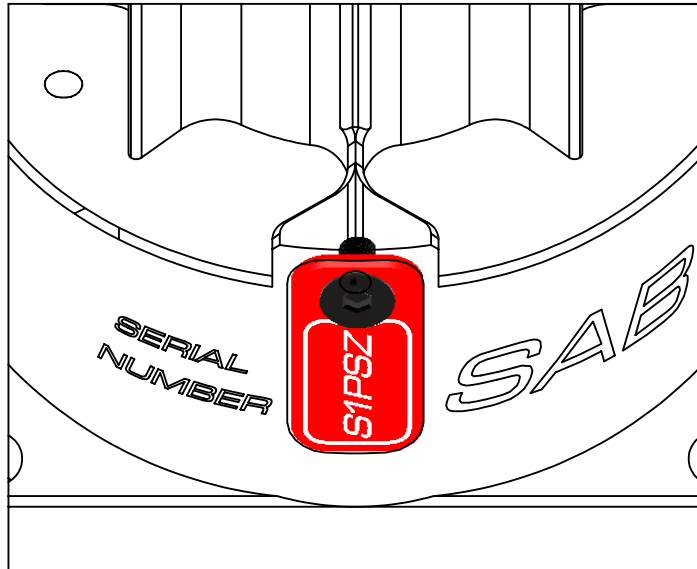

Please read this user manual carefully, it contains instructions for the correct assembly of the model.
Please refer to the web site www.goblin-helicopter.com for updates and other important information.

VERY IMPORTANT

You will find your serial number on the RED plate of the transmission module and on the product card included with your kit.
Please take a moment to register your kit online via our web site at:

<http://www.goblin-helicopter.com>

It is extremely important that you take a moment to register your helicopter with us. This is the only way to ensure that you are properly informed about changes to your kit, such as upgrades, retrofits and other important developments. SAB Heli Division cannot be held responsible for any issues with your model and will not provide support unless you register your model.

Thank you for your purchase, we hope you enjoy your new Goblin helicopter!

SAB Heli Division

INDEX

- 1 – Introduction
- 2 – Important Notes**
- 3 – Note for Assembly**
- 4 – Carbon Rod Assembly
- 5 – Transmission Group Assembly
- 6 – Swashplate Servos Assembly
- 7 – Engine Unit Assembly

- 8 – Main Frame Assembly
- 9 – Tank Unit Assembly
- 10 – Landing Gear Assembly
- 11 – Head Assembly
- 12 – Tail Assembly
- 13 – Tail Boom Assembly
- 14 – Assembling of the modules

- 15 – Installation of The FBL/RX
- 16 – Installation of The Battery
- 17 – Installation of The Canopy
- 18 – In flight**
- 19 – Maintenance
- 20 – Transmission Module
- 21 – Check list**
- 22 – Spare Parts

GOBLIN KRAKEN 580 NITRO TECHNICAL SPECIFICATIONS

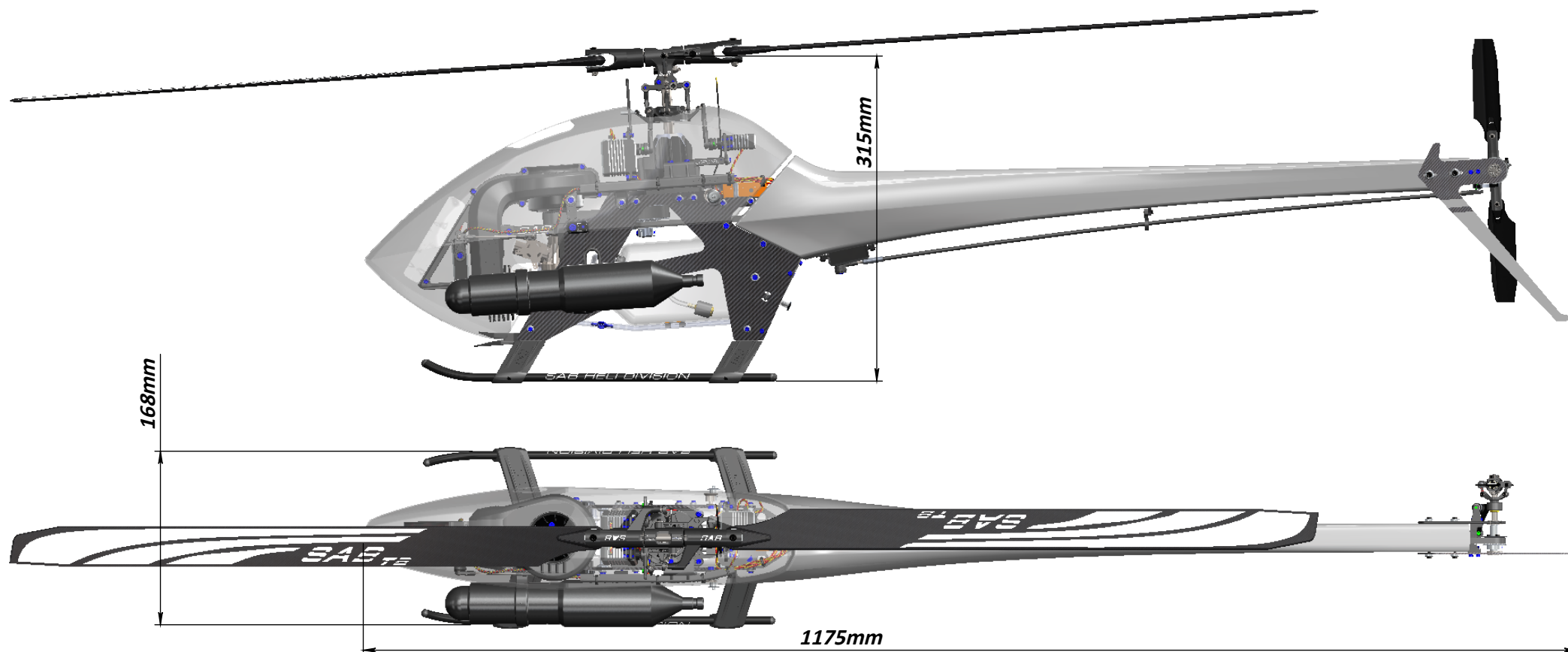

- **RTF Approx. Weight:** 3090 g (RTF no fuel).
- **Main blade length:** 550mm to 600mm (570mm included).
- **Tail blade length:** 95 to 105 mm (95mm included).
- **Main rotor diameter:** 1270 mm (with 570 mm blades).
- **Tail rotor diameter:** 260 mm (with 95 mm tail blades).
- **Engine:** .50 to .60 Nitro Heli Engine.
- **Cyclic Servos:** Mini size 35 mm (Standard size 40mm option).
- **Tail Servo:** Standard size 40mm.
- **Throttle Servo:** Mini size 35 mm.
- **Main Rotor Ratio:** 8.6 to 7.4 :1 (26T included: 8:1).
- **Tail Rotor Ratio :** 5.3-4.9:1 (23T included: 4.9:1).
- **Tank Capacity:** 440ml.
- **RX Battery Size:** 2S-1800 mAh.

IMPORTANT NOTES

- *This radio controlled helicopter is not a toy.
- *This radio controlled helicopter can be very dangerous.
- *This radio controlled helicopter is a technically complex device which has to be built and handled very carefully.
- *This radio controlled helicopter must be built following these instructions. This manual provides the necessary information to correctly assemble the model.
It is necessary to carefully follow all the instructions.
- *Inexperienced pilots must be monitored by expert pilots.
- *All operators must wear safety glasses and take appropriate safety precautions.
- *A radio controlled helicopter must only be used in open spaces without obstacles, and far enough from people to minimize the possibility of accidents or of injury to property or persons.
- *A radio controlled helicopter can behave in an unexpected manner, causing loss of control of the model, making it very dangerous.
- *Lack of care with assembly or maintenance can result in an unreliable and dangerous model.

***Neither SAB Heli Division nor its agents have any control over the assembly, maintenance and use of this product. Therefore, no responsibility can be traced back to the manufacturer. You hereby agree to release SAB Heli Division from any responsibility or liability arising from the use of this product.**

SAFETY GUIDELINES

- *Fly only in areas dedicated to the use of model helicopters.
- *Follow all control procedures for the radio frequency system.
- *It is necessary that you know your radio system well. Check all functions of the transmitter before every flight.
- *The blades of the model rotate at a very high speed; be aware of the danger they pose and the damage they may cause.
- *Never fly in the vicinity of other people.

DAMAGE LIMITS

SAB HELI DIVISION SHALL NOT BE LIABLE FOR SPECIAL, INDIRECT OR CONSEQUENTIAL DAMAGES, LOSS OF PROFITS OR PRODUCTION OR COMMERCIAL LOSS IN ANY WAY CONNECTED WITH THE PRODUCT, WHETHER SUCH CLAIM IS BASED IN CONTRACT, WARRANTY, NEGLIGENCE, OR STRICT LIABILITY. Further, in no event shall the liability of SAB Heli Division exceed the individual price of the Product on which liability is asserted. As SAB Heli Division has no control over use, setup, final assembly, modification or misuse, no liability shall be assumed nor accepted for any resulting damage or injury. By the act of use, setup or assembly the user accepts all resulting liability. If you as the Purchaser or user are not prepared to accept the liability associated with the use of this Product, you are advised to return this Product immediately in new and unused condition to the place of purchase.

LIMITED WARRANTY

SAB Heli Division reserves the right to change or modify this warranty without notice and disclaims all other warranties, express or implied.

- (a)** This warranty is limited to the original Purchaser (“Purchaser”) and is not transferable. REPLACEMENT AS PROVIDED UNDER THIS WARRANTY IS THE EXCLUSIVE REMEDY OF THE PURCHASER This warranty covers only those Products purchased from an authorized SAB Heli Division dealer. Third party transactions are not covered by this warranty. Proof of purchase is required for warranty claims.
- (b)** Limitations- SAB HELI DIVISION MAKES NO WARRANTY OR REPRESENTATION, EXPRESS OR IMPLIED, ABOUT NONINFRINGEMENT, MERCHANTABILITY OR FITNESS FOR A PARTICULAR PURPOSE OF THE PRODUCT. THE PURCHASER ACKNOWLEDGES THAT THEY ALONE HAVE DETERMINED THAT THE PRODUCT WILL SUITABLY MEET THE REQUIREMENTS OF THE PURCHASER’S INTENDED USE.
- (c)** Purchaser Remedy- SAB Heli Division’s sole obligation hereunder shall be that SAB Heli Division will, at its option, replace any Product determined by SAB Heli Division to be defective In the event of a defect, this is the Purchaser’s exclusive remedy. Replacement decisions are at the sole discretion of SAB Heli Division. This warranty does not cover cosmetic damage or damage due to acts of God, accident, misuse, abuse, negligence, commercial use, or modification of or to any part of the Product. This warranty does not cover damage due to improper installation, operation, maintenance or attempted repair by anyone.

NOTE FOR ASSEMBLY



ADDITIONAL COMPONENTS REQUIRED





- *Engine: .50 to .60 Nitro Heli Engine.
- *Muffler suited for the engine being used.
- *Batteries: 2S/1600-3000mAh.
- *Governor unit.
- *1 flybarless 3 axis control unit
- *Radio power system.
- *1 throttle servo (Mini Size).
- *3 cyclic servos (Mini Size).
- *1 tail rotor servo (Standard Size).
- *6 channel radio control system on 2.4 GHz
- *Fuel.

TOOLS, LUBRICANTS, ADHESIVES

- *Generic pliers.
- *Hexagonal driver, size 1.5, 2, 2.5, 3mm.
- *4/5mm T-Wrench.
- *5.5mm Socket wrench (for M3 nuts).
- *8mm Hex fork wrench (for M5 nuts).
- *Medium threadlocker (SAB p/n HA116-S).
- *Strong retaining compound (SAB p/n HA115-S).
- *Spray lubricant (eg. Tri-Flow Oil).
- *Synthetic grease (eg. Microlube 261).
- *Cyanoacrylate adhesive.
- *Pitch Gauge (for set-up).
- *Soldering equipment (for motor wiring).

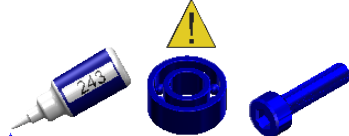
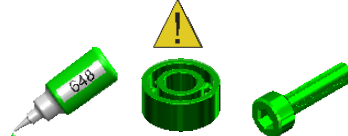
NOTES FOR ASSEMBLY

Please refer to this manual for assembly instructions for this model. Follow the order of assembly indicated. The instructions are divided into chapters, which are structured in a way that each step is based on the work done in the previous step. Changing the order of assembly may result in additional or unnecessary steps. Use thread lockers and retaining compounds as indicated. In general, each bolt or screw that engages with a metal part requires thread lock. It is necessary to pay attention to the symbols listed below:

 <p>Important</p>	 <p>Blue screw and blue bearing in the illustration means you need to use: Thread Locker Medium Strength (SAB HA116-S)</p>	 <p>Green screw and Green bearing in the illustration means you need to use: Use retaining compound (SAB HA115-S)</p>
 <p>Indicates that for this assembly phase you need materials that are: Foam xxx, BAG xxx.</p>	 <p>Use CA Glue</p>	 <p>Use Proper Lubricant</p>

INSIDE THE MAIN BOX THERE ARE:

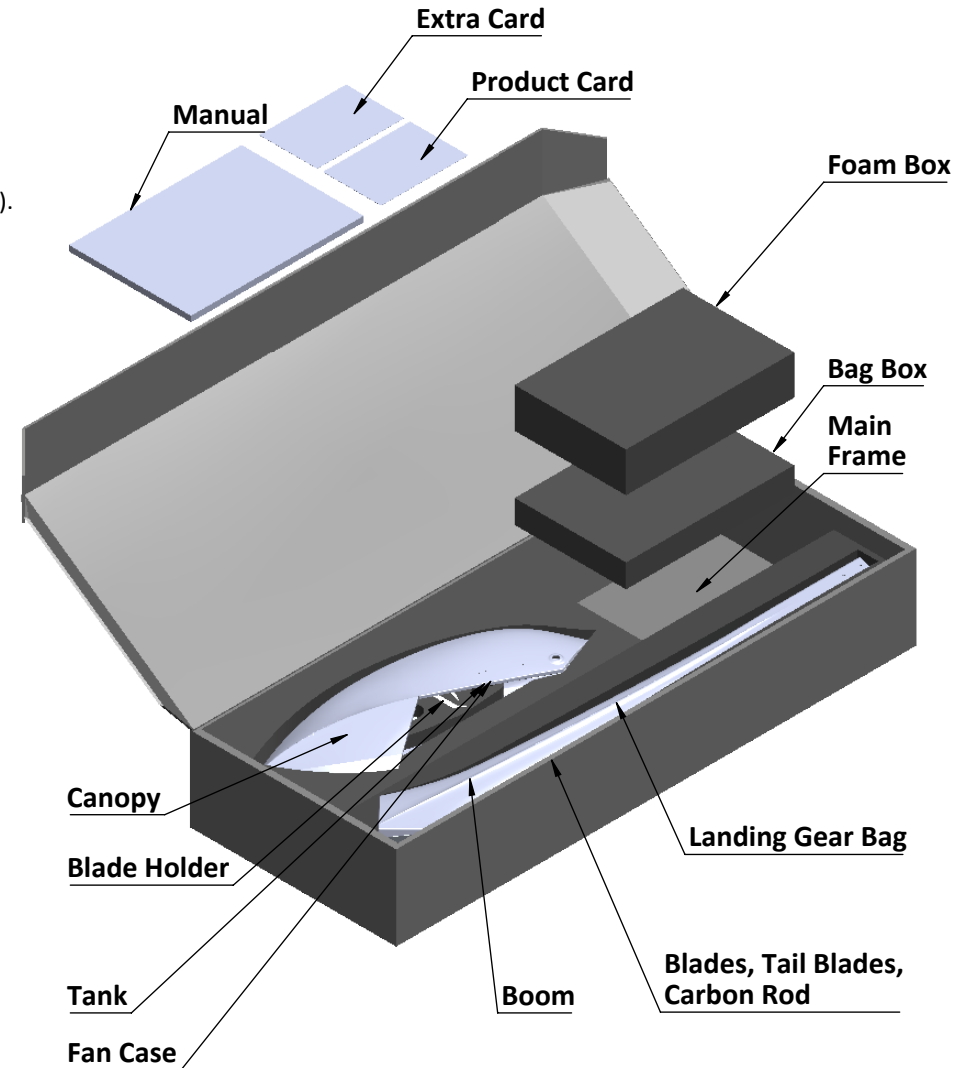

The assembly process is described in the following chapters. Each chapter provides you with the box, bag and/or foam numbers you will need for that chapter. The information is printed in a black box in the upper corner of the page.

BAG 1

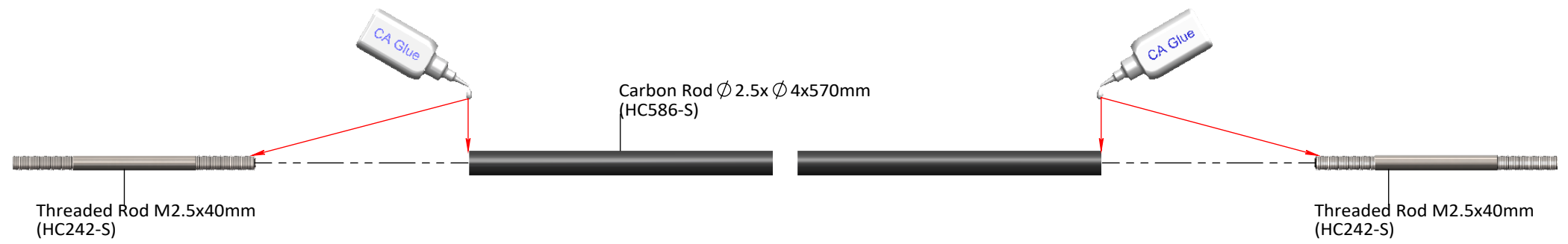

NOTE:

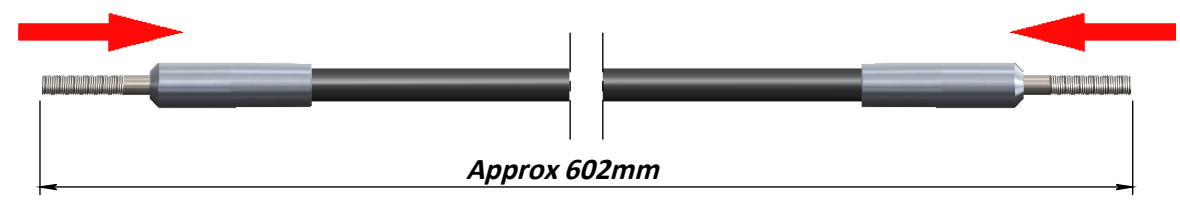

BAG 2.1, FOAM 1

CLUTCH UNIT ASSEMBLY

SECTION

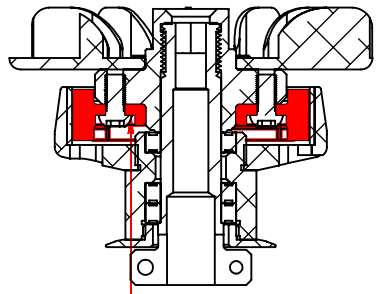

Note:
Counterbore external side.

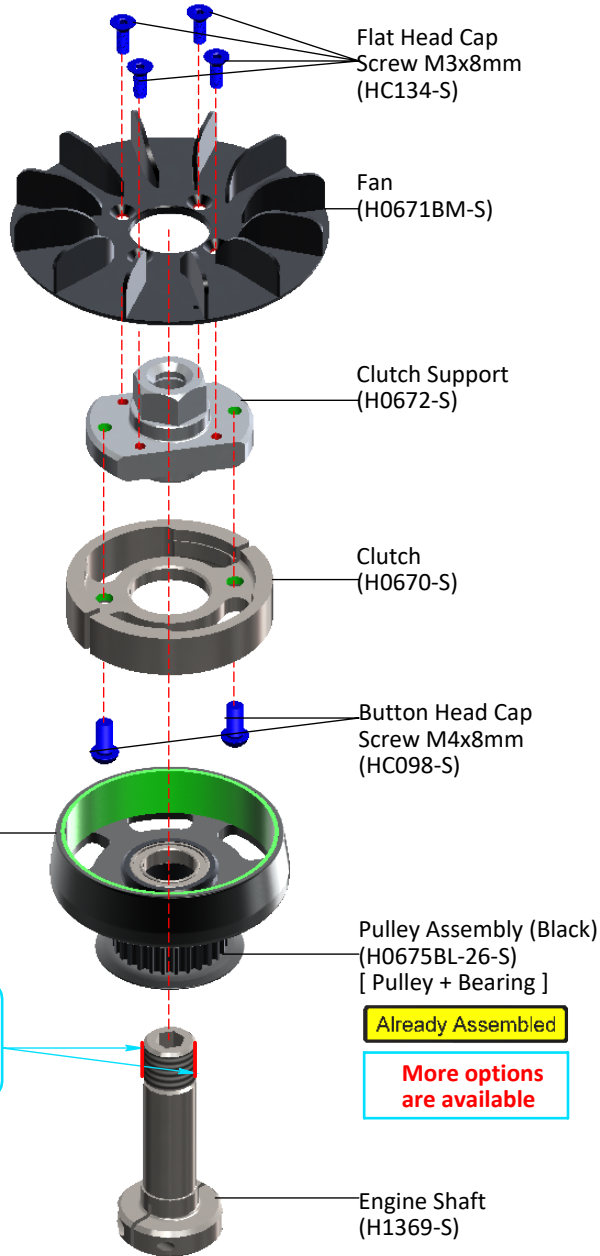

IMPORTANT NOTE

Don't use any retaining compound in red area between H0668 and H0672.

Already Assembled

More options are available

ENGINE MOUNT ASSEMBLY

BAG 2.2, FOAM 1

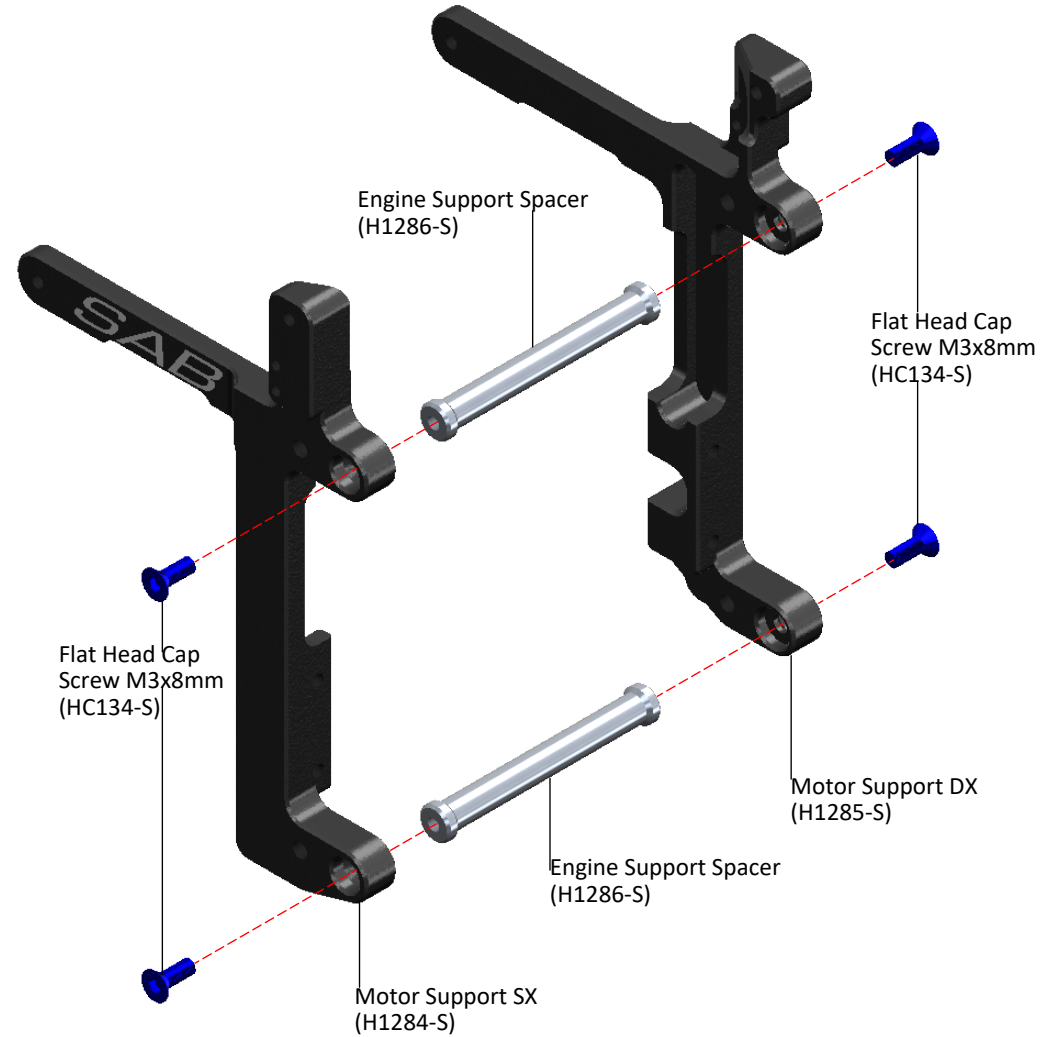

BAG 2.3

ENGINE ASSEMBLY

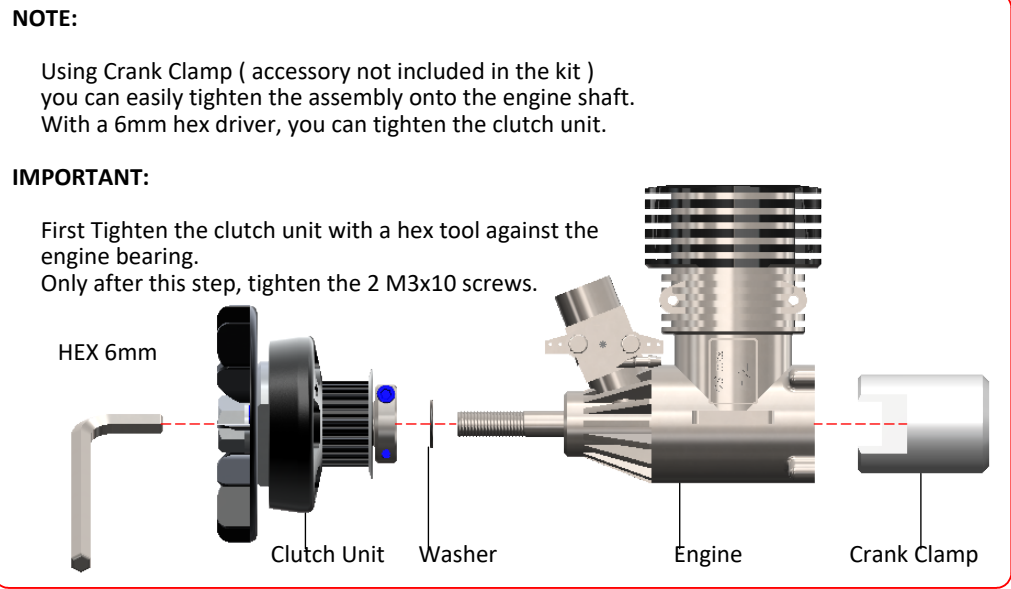
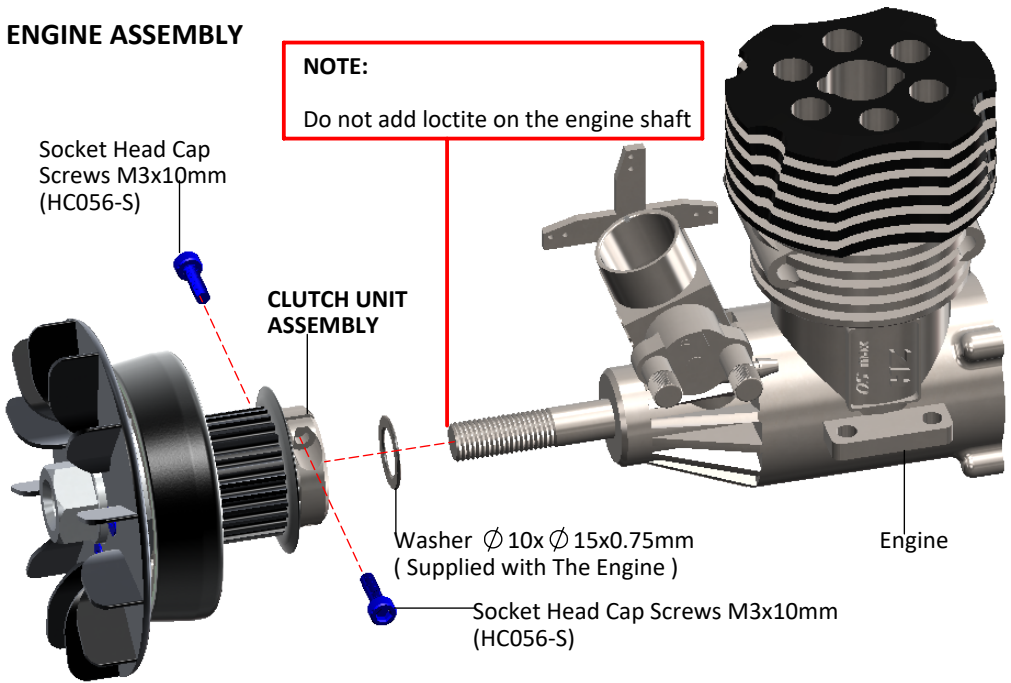

MAIN RATIO

It is possible to have 5 ratios using the following Pulleys:

H0675BL-28-S	50/28	7.4
H0675BL-27-S	50/27	7.7
H0675BL-26-S	50/26	8.0
H1213-S: OWB Pulley 54T	54/27	7.3
H1213-S: OWB Pulley 54T	54/26	8.6

The KIT includes ratio : 50T-26T -> 8.0

Depending on the head speed you want, we suggest to use:
Ratio from 8 to 7.4 for 570mm Blade size.
Ratio from 8.6 to 8 for 600mm Blade size.

ENGINE MOUNT ASSEMBLY

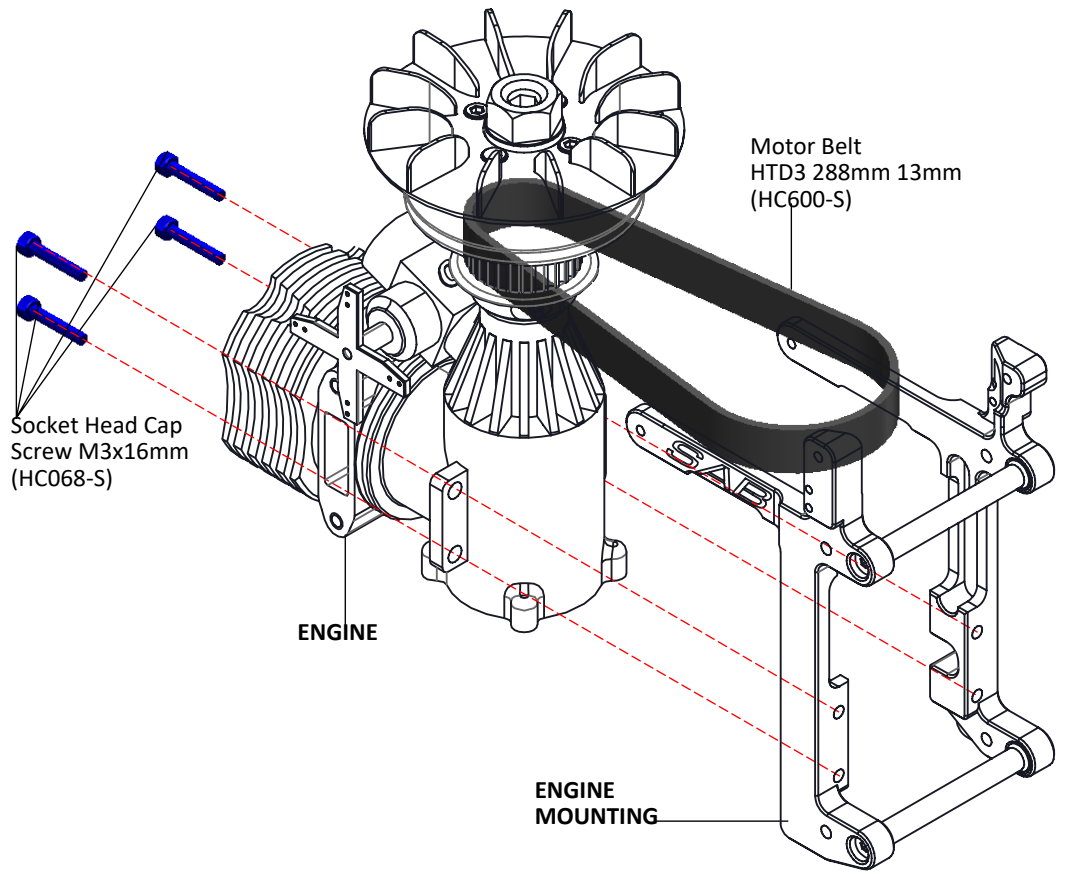

INSTALLATION OF THE RPM SENSOR

On the 580 nitro it is possible to use two different methods to install an RPM sensor. The first is a backplate sensor as demonstrated in the picture on the right.

P.S: Not all YS engines can support this method. Please seek further guidance from your engine manufacturer.

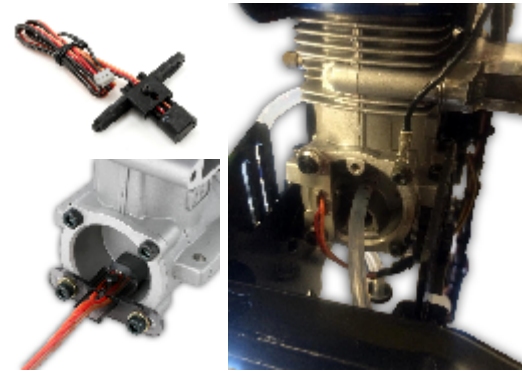

The second is to use two magnets on the fan. Please use the following methods for installation:

Install 2 magnets on the fan with epoxy glue (please ensure to clean the parts with degreaser before glueing together)

[Fig. 1]). To install the sensor, you can use the two pre-cut M2.5 holes.

Not all sensors are the same, so you can adapt the position with the carbon support (H0729).

With Align and Spartan sensors, you can use the part of the support that already has holes in it.

With any other sensor, you can use the part without holes and adapt as required.

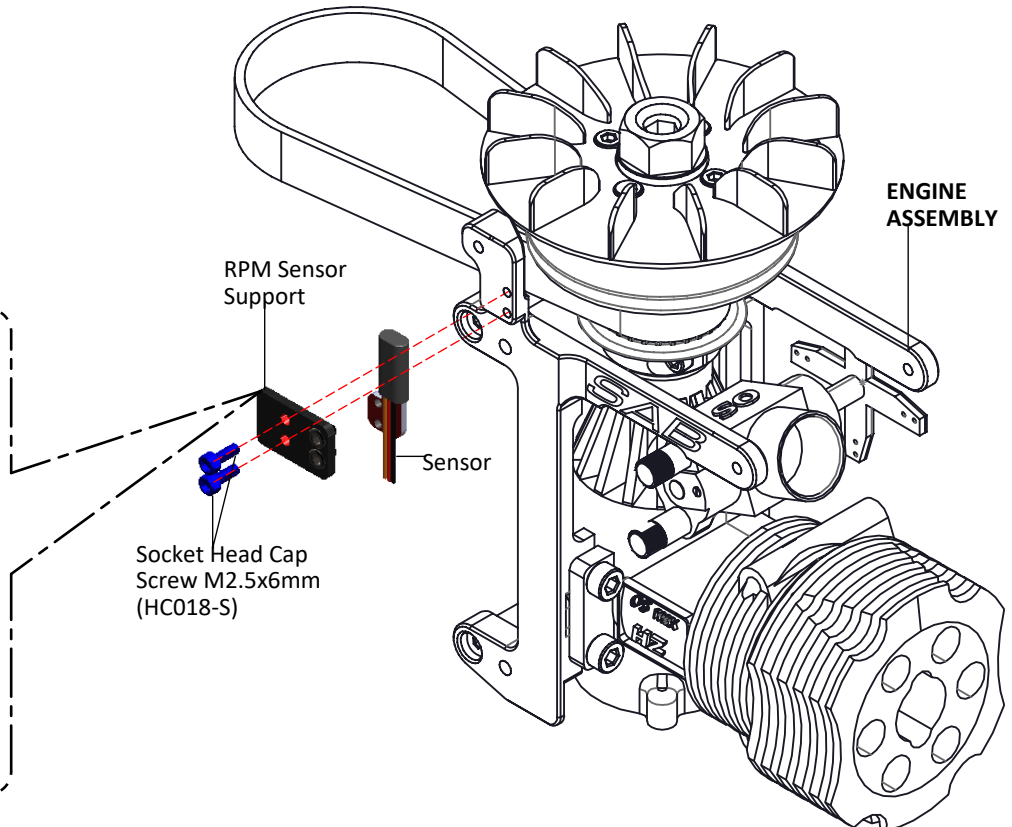
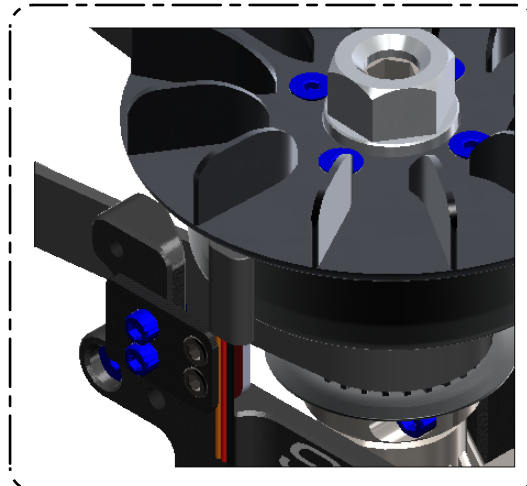
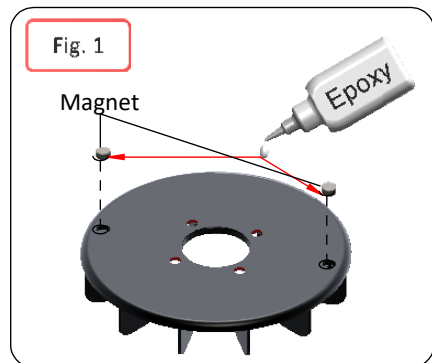
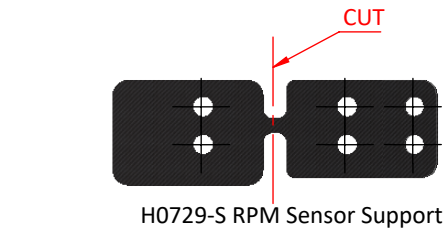

BAG 3.1

FAN CASE SX ASSEMBLY

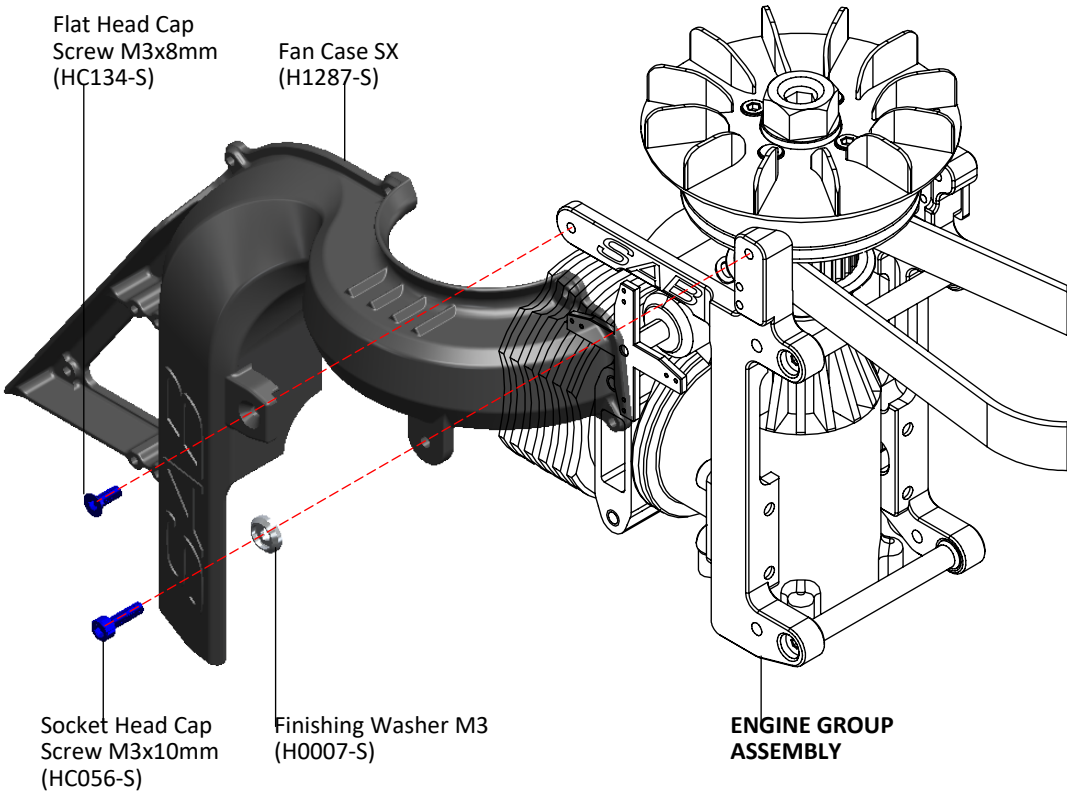

FAN CASE DX ASSEMBLY

The fan case is designed symmetrically. To install the servo it is necessary to cut a small part in the right case as show in the Figure.

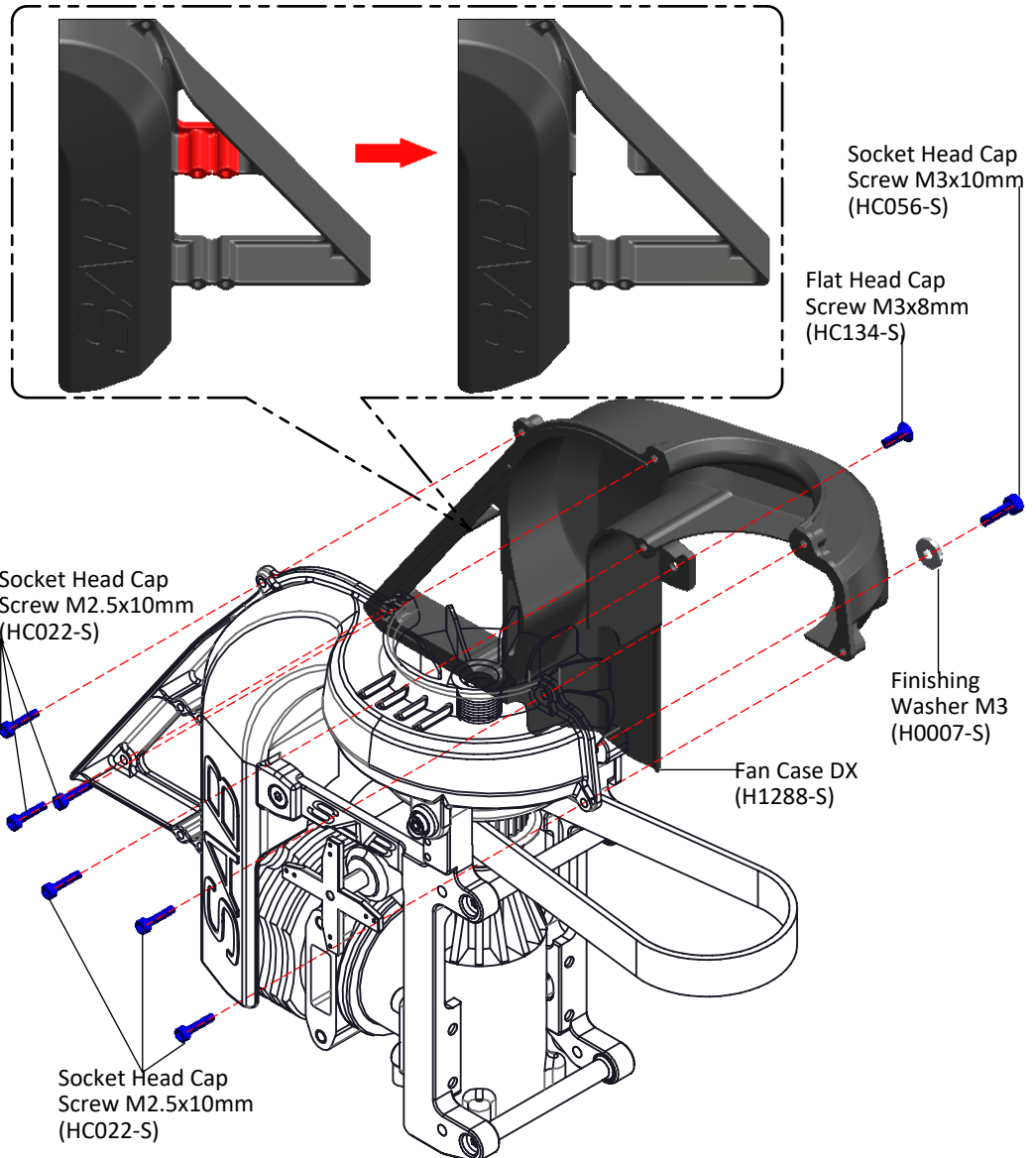

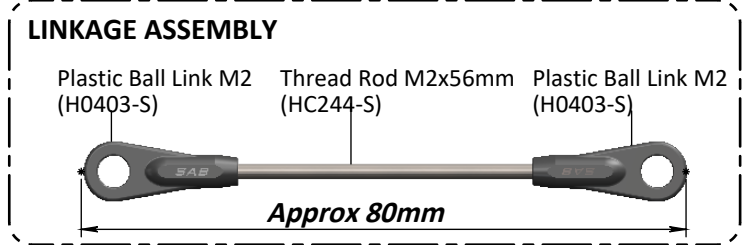
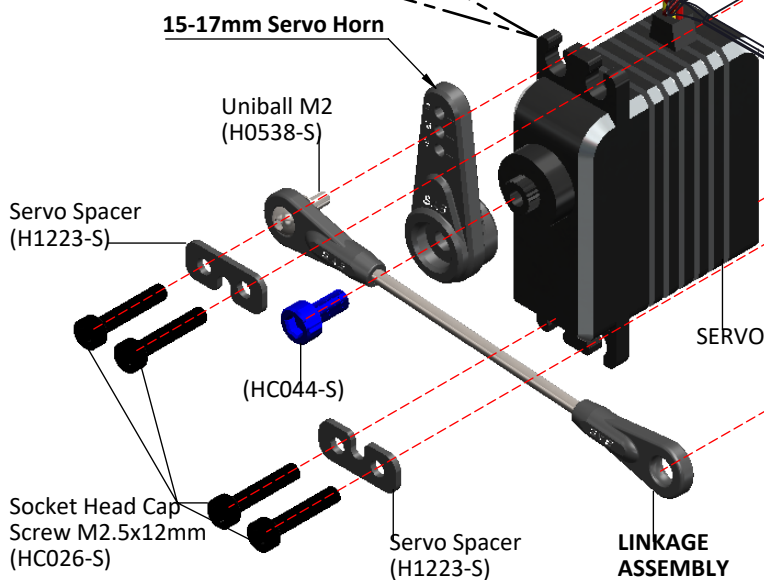
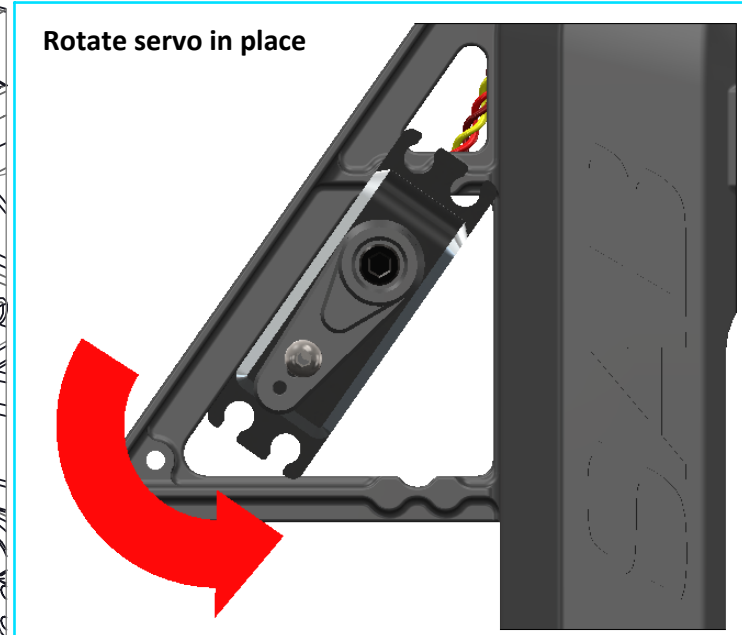
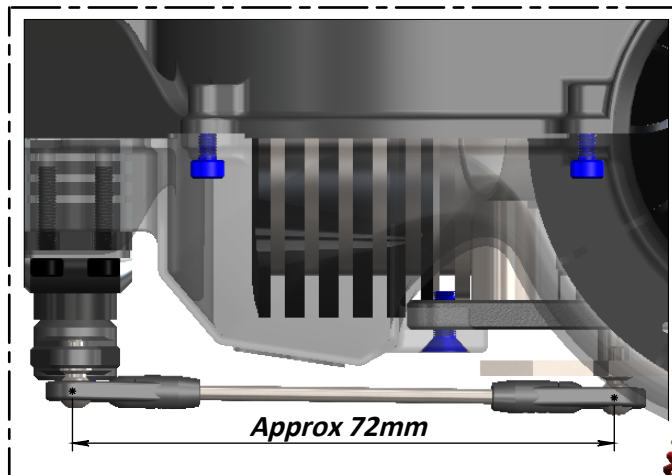

BAG 4

MAIN FRAME ASSEMBLY

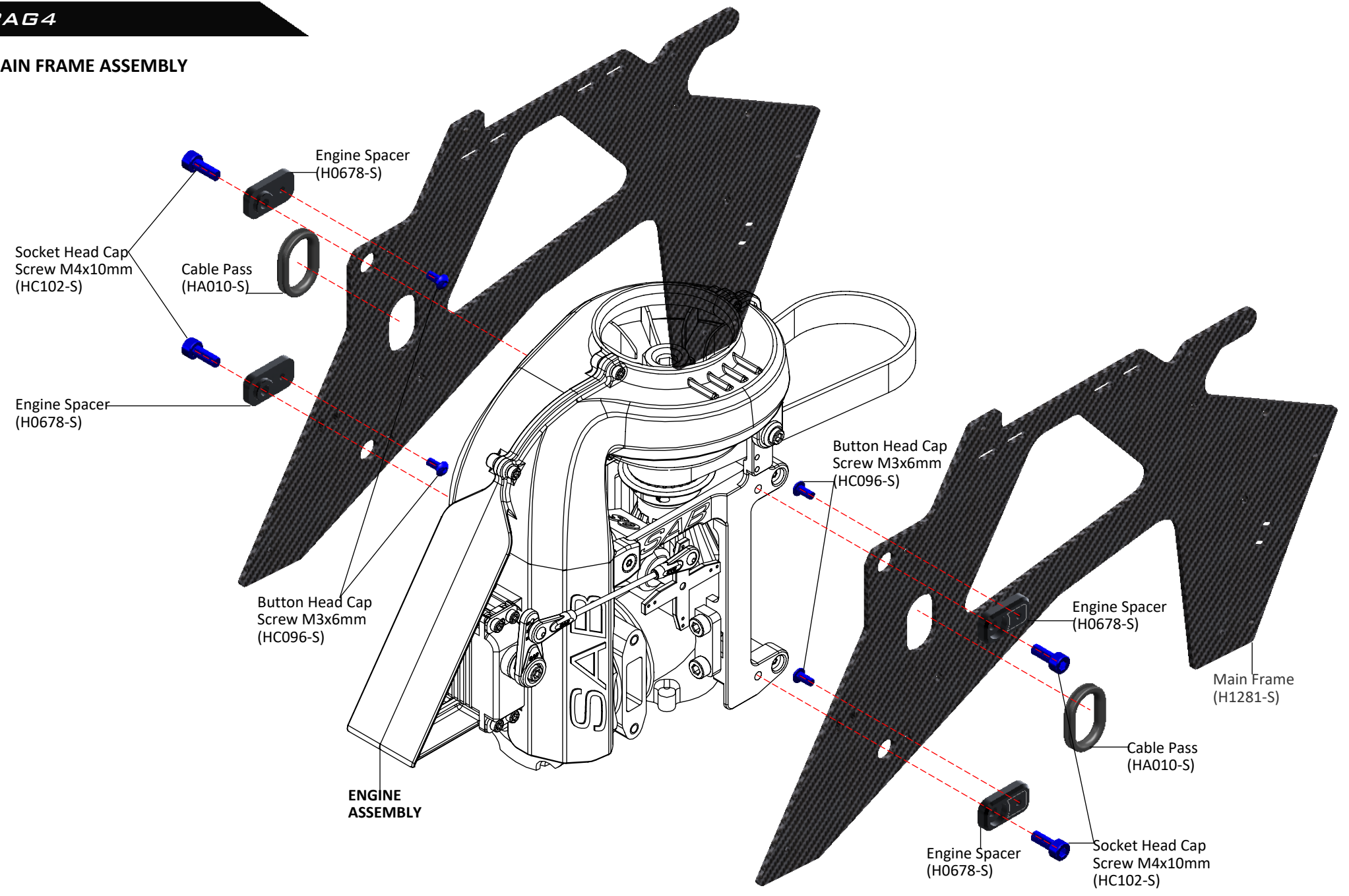

TANK LINE ASSEMBLY

BAG 5.1

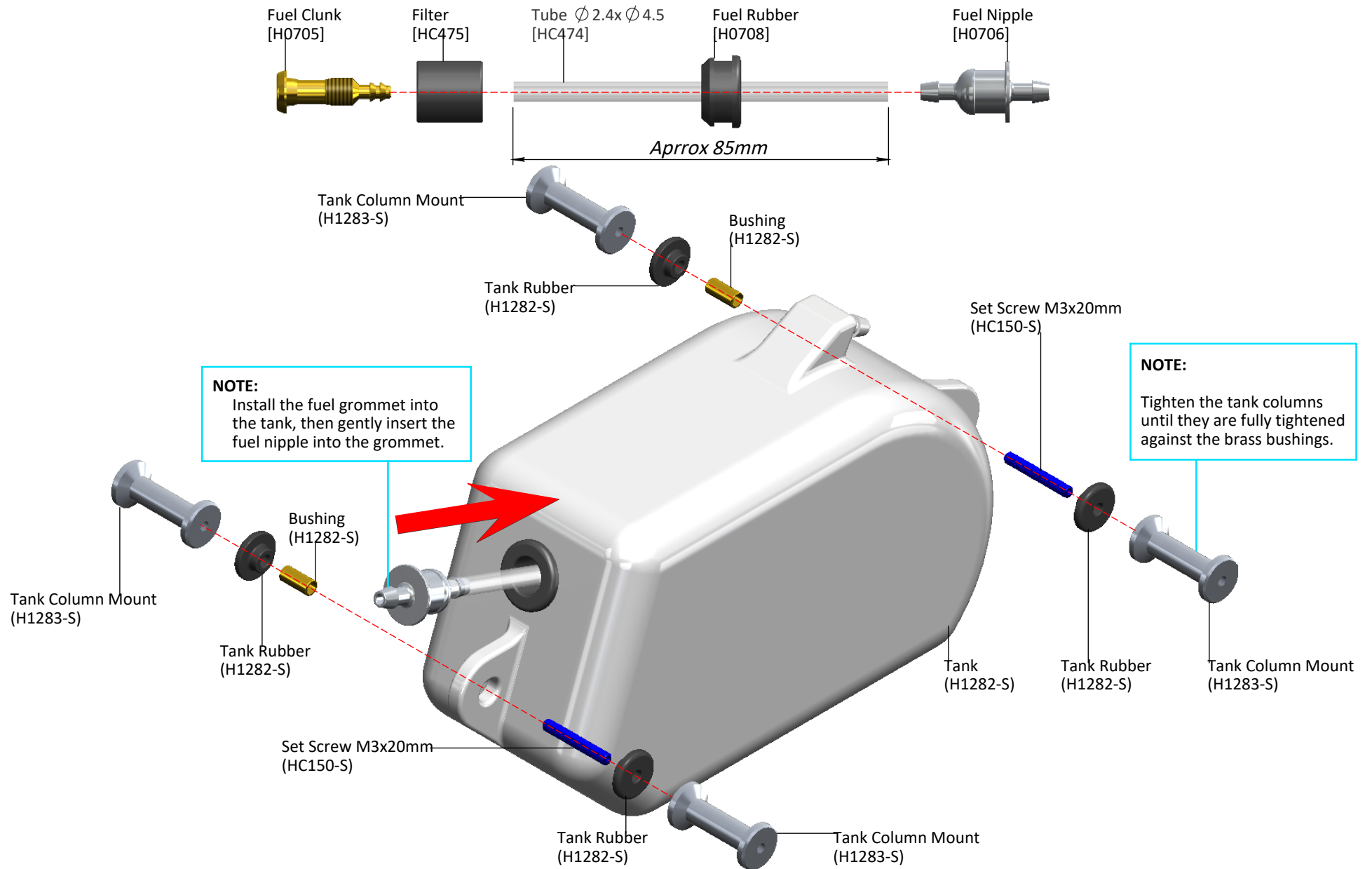

BAG 5.2

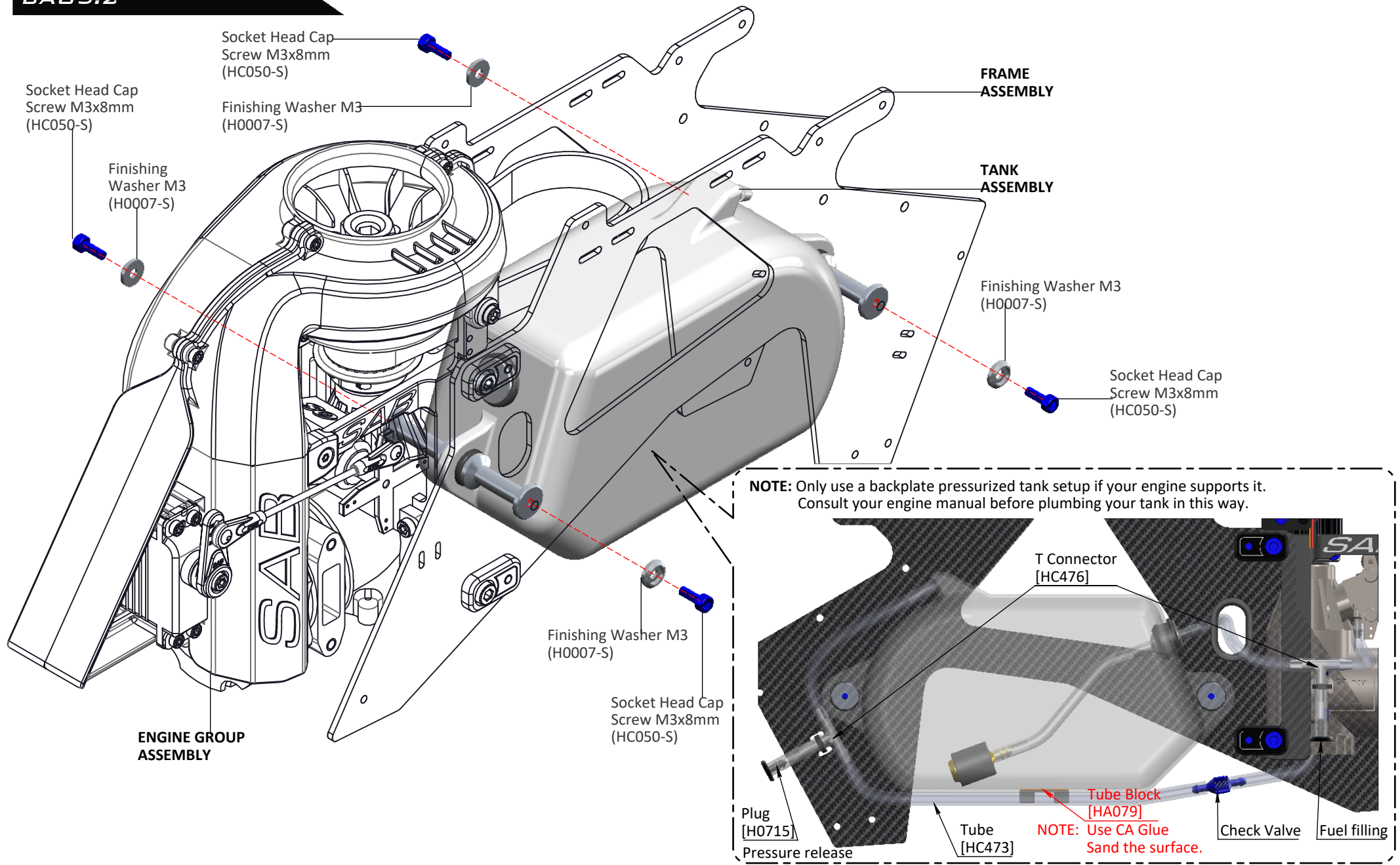

LANDING GEAR ASSEMBLY

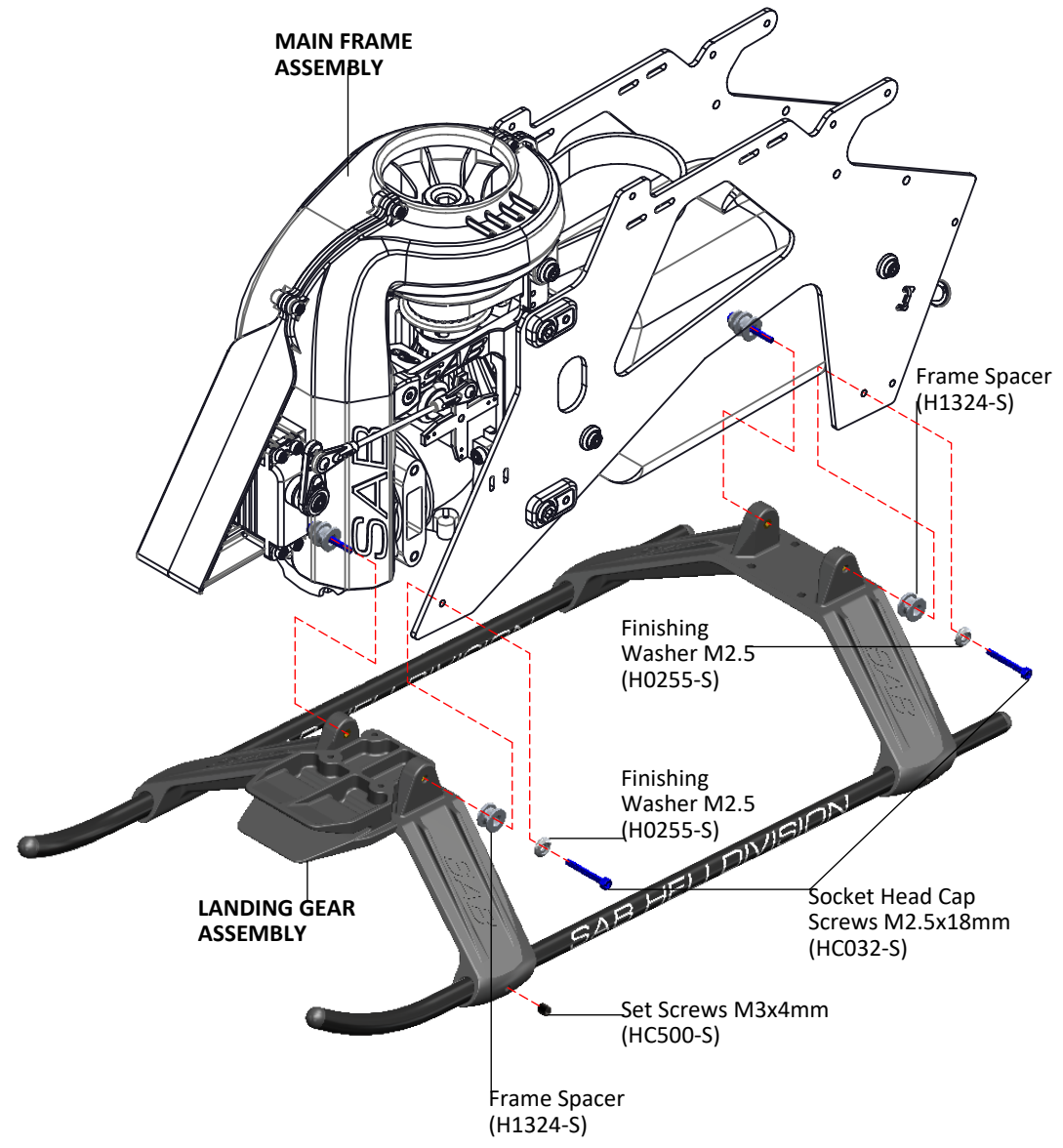
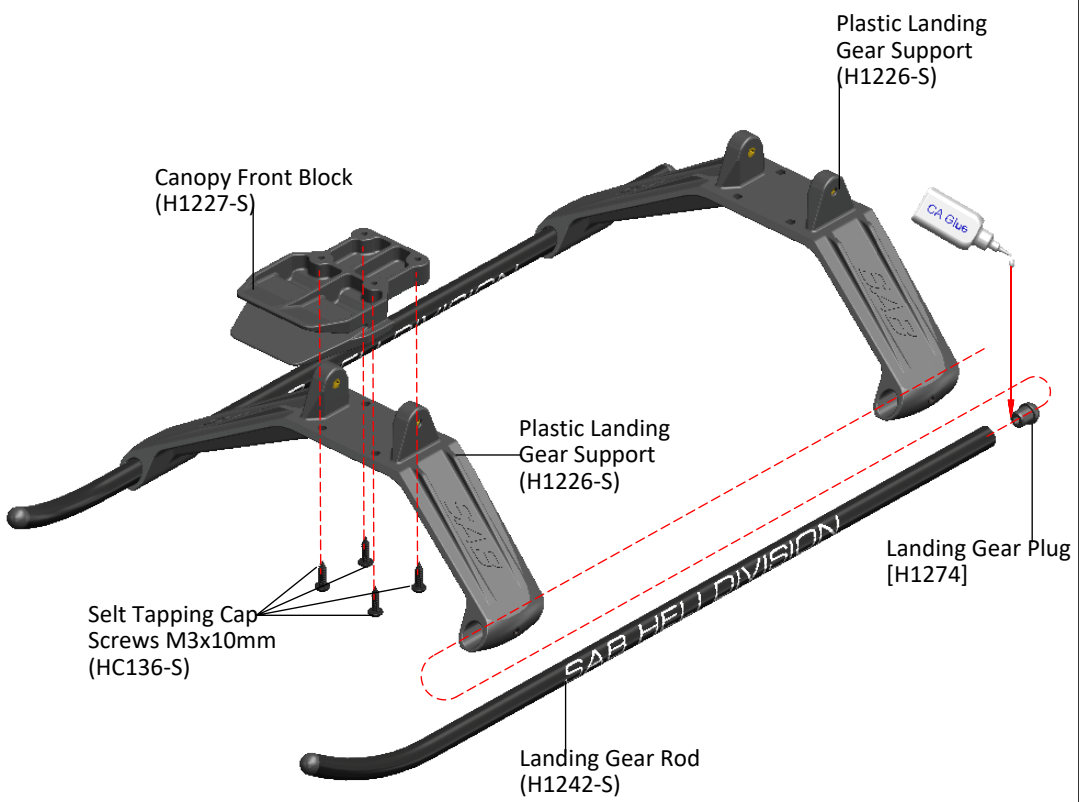

TRANSMISSION GROUP ASSEMBLY AND VERIFIED

The unit is ready to use
Check page 40 for more information.

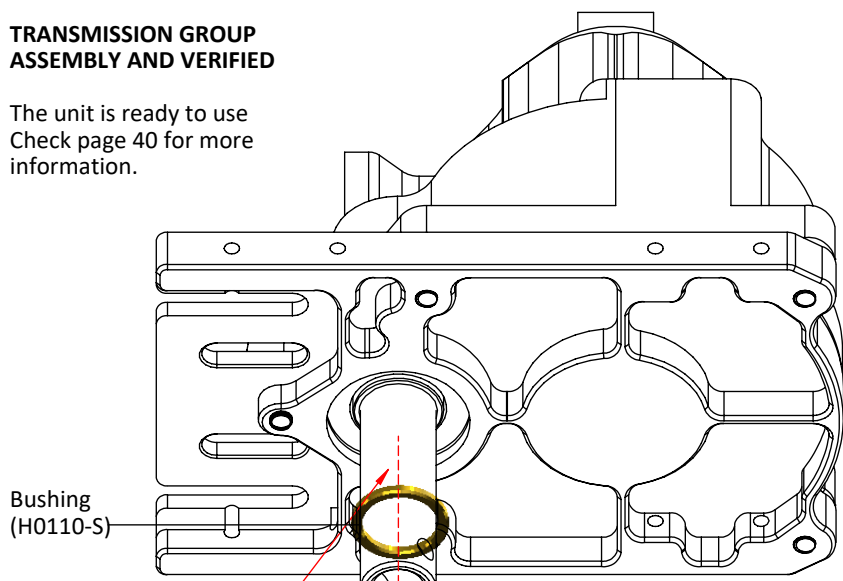

Bushing (H0110-S)

Free Wheel Clutch grease HA075



Main Pulley Z50 (H1213-S)

Already Assembled With Loctite

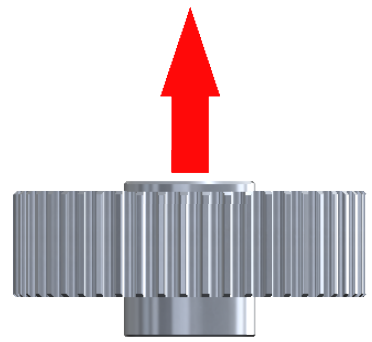
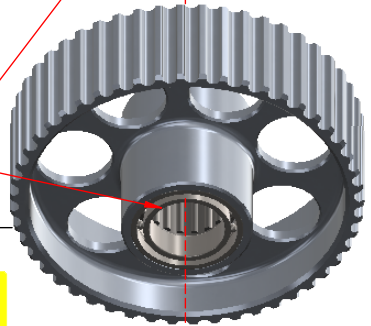

Front Tail Pulley Z27 (H1214-S)

Already Assembled With Loctite

NOTE
DO NOT over torque the screw.

Socket Head Cap Shoulder M3x18mm (HC079-S)

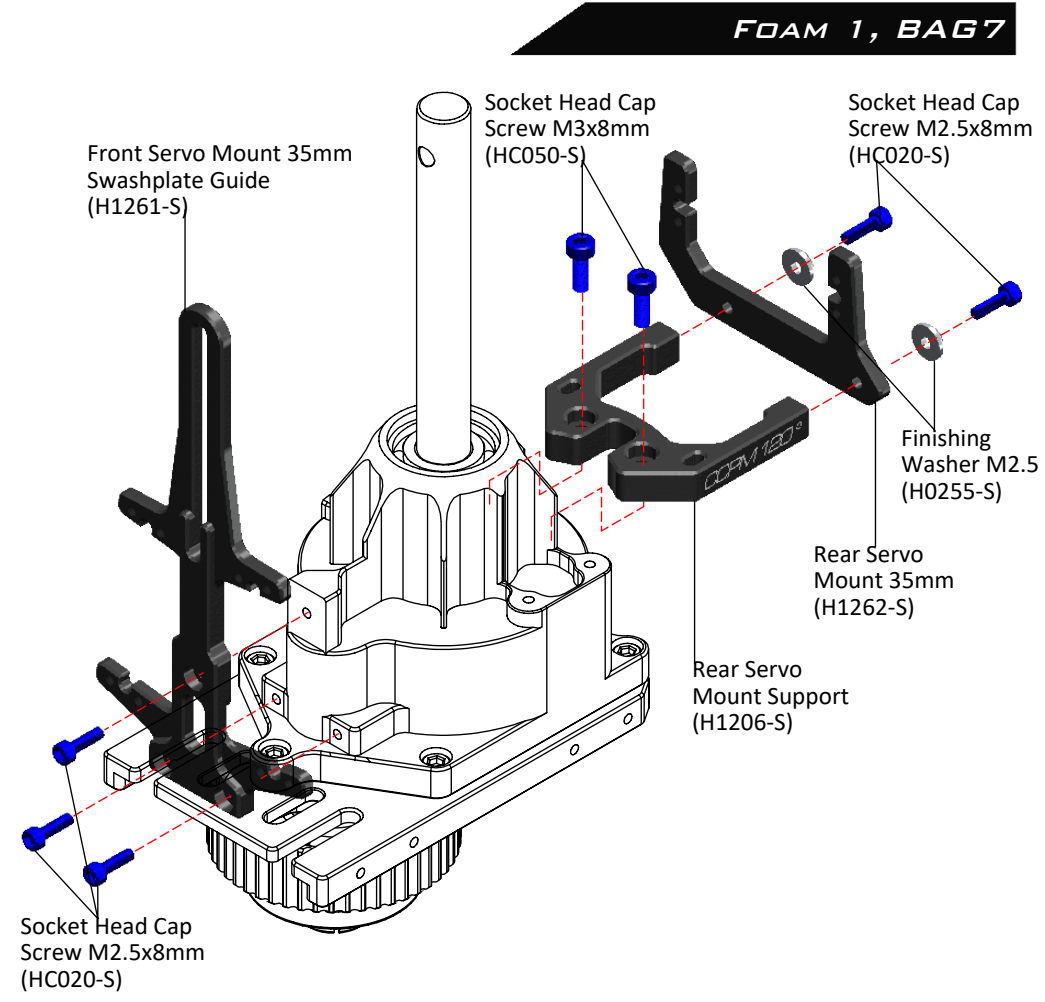
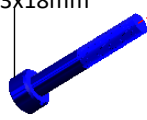

FOAM 1, BAG7

STANDARD SIZE SERVOS

Standard size servos can be used [p/n H1217-S & H1207-S] (not included in the KIT)

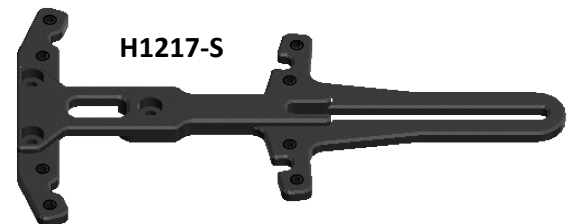

BAGB

SERVO ASSEMBLY

The linkage ball must be positioned 17-18 mm out on the servo arm. The recommended servo arm to use is: SAB p/n [HA050/HA051].

Ensure the alignment of the servo arms (and sub trim set) before installing the servos in the model.

Proceed with installation following the instructions below. You can use the G10 servo tool to align the front servo arms with the theoretical horizontal line. **(Figure 3)**

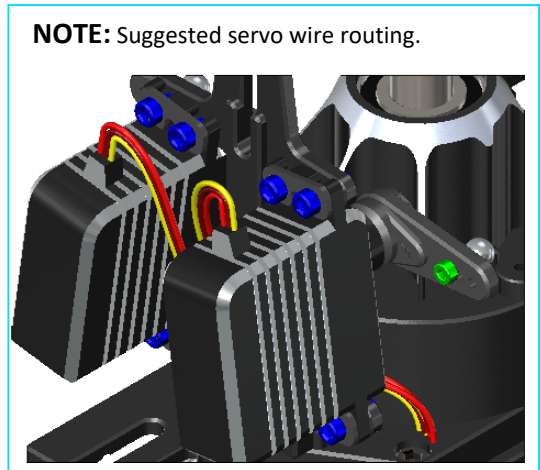
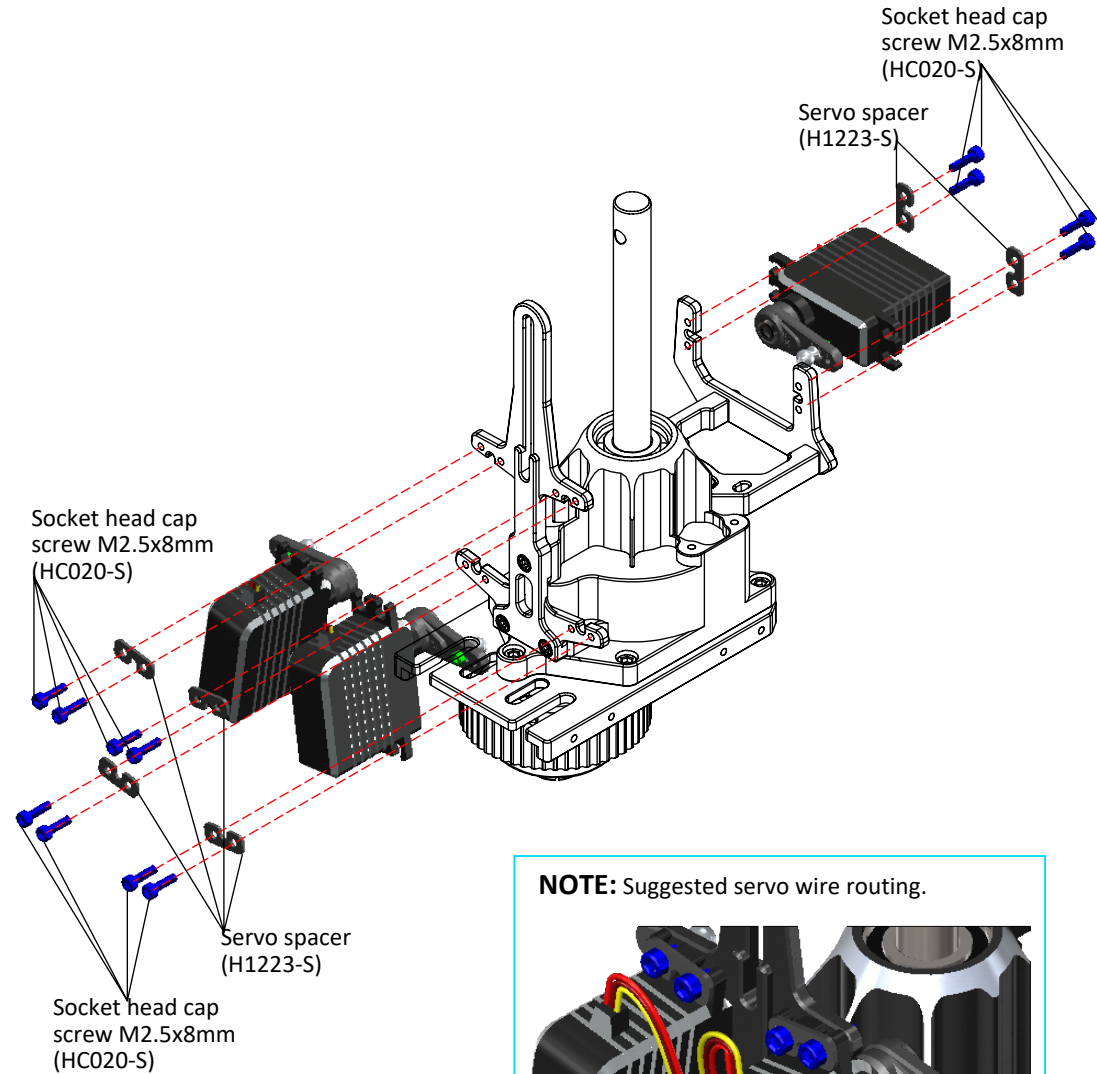
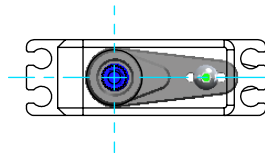
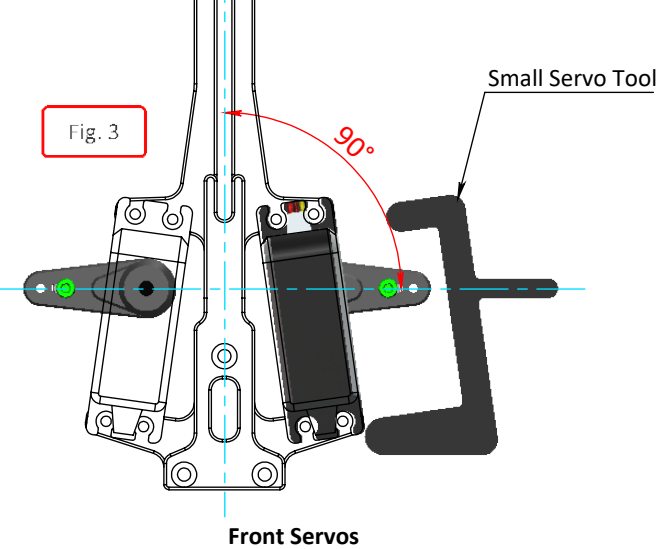
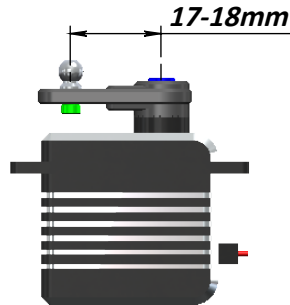
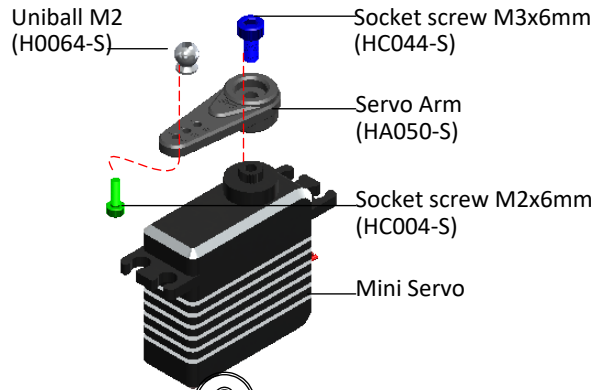

FOAM 2, BAG 9

UNIBALL RADIUS ARM ASSEMBLY ...X2

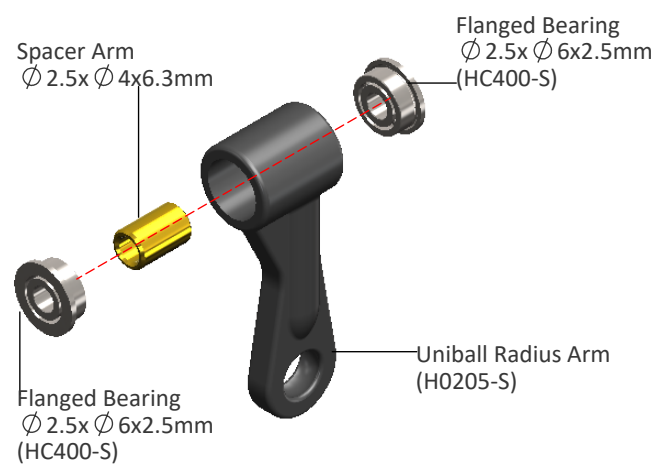

RADIUS ARM ASSEMBLY ...X2

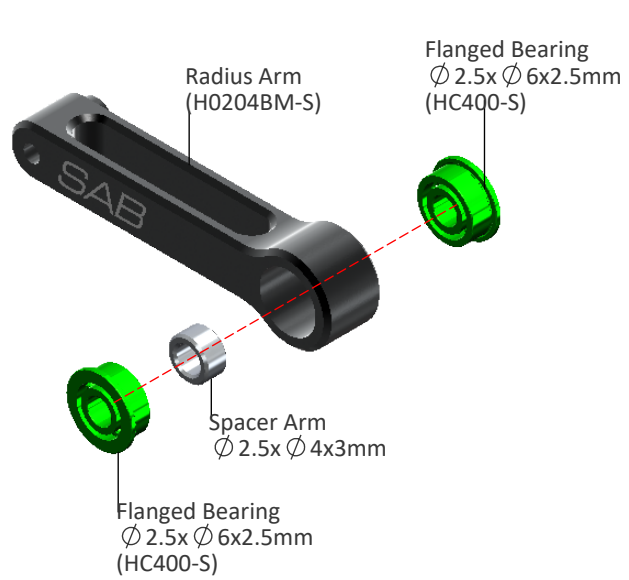

LINKAGE ROD ASSEMBLY ...X2

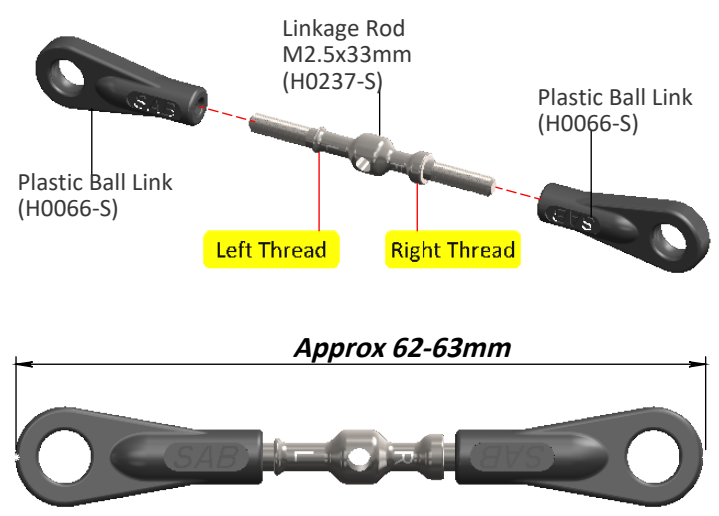

CENTER HUB ASSEMBLY

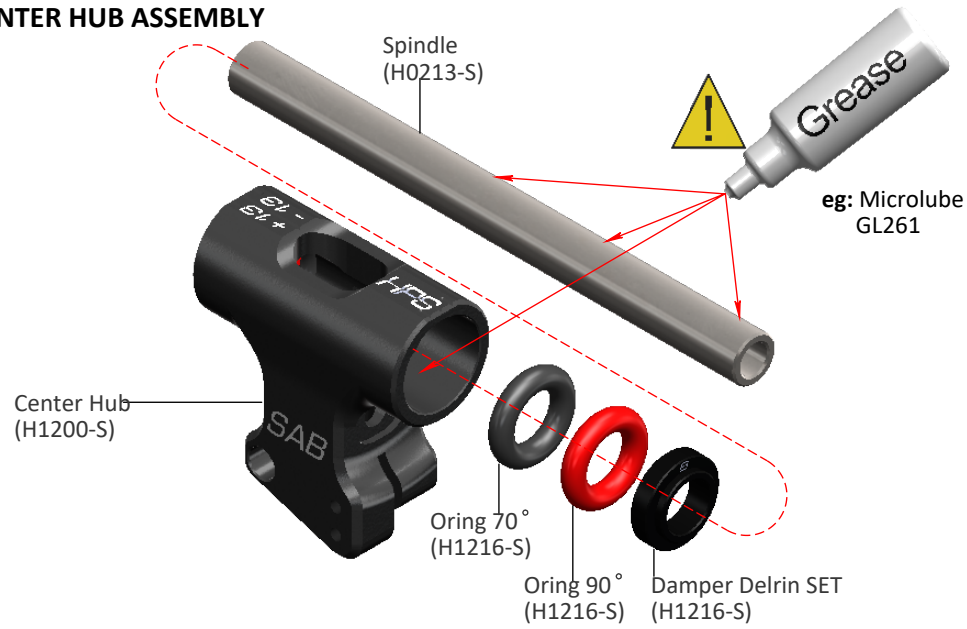

O-RING SET UP

- Internal = 70°, External = 90° → Sport & 3D flight.
- Internal = 90°, External = 90° → Hard 3D.

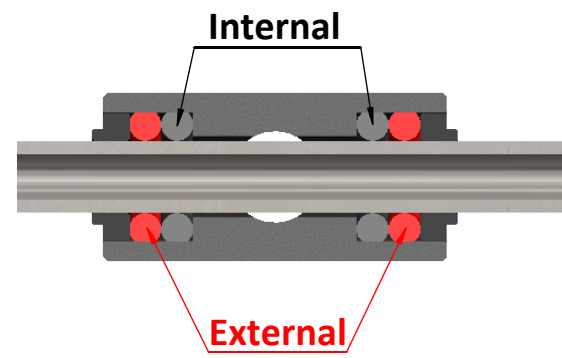

NOTE: The small lip faces out towards the blade grip.

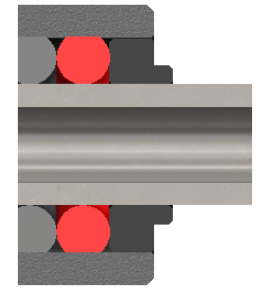

It is a normal (especially with the 90° + 90° O-ring set-up) to feel tight after initial assembly as the axial preload is usually high when the helicopter is brand new.

The preload will loosen up after 5-10 flights allowing the system to become smooth.

NOTE:



Washer $\phi 8 \times \phi 14 \times 0.2\text{mm}$ [HC228-S]
 After approximately 10/20 flights, please check preload, you can add one 0.2mm shim (HC232) on each side if preload has changed. However, we suggest to replace the o-rings after about 100 flights.

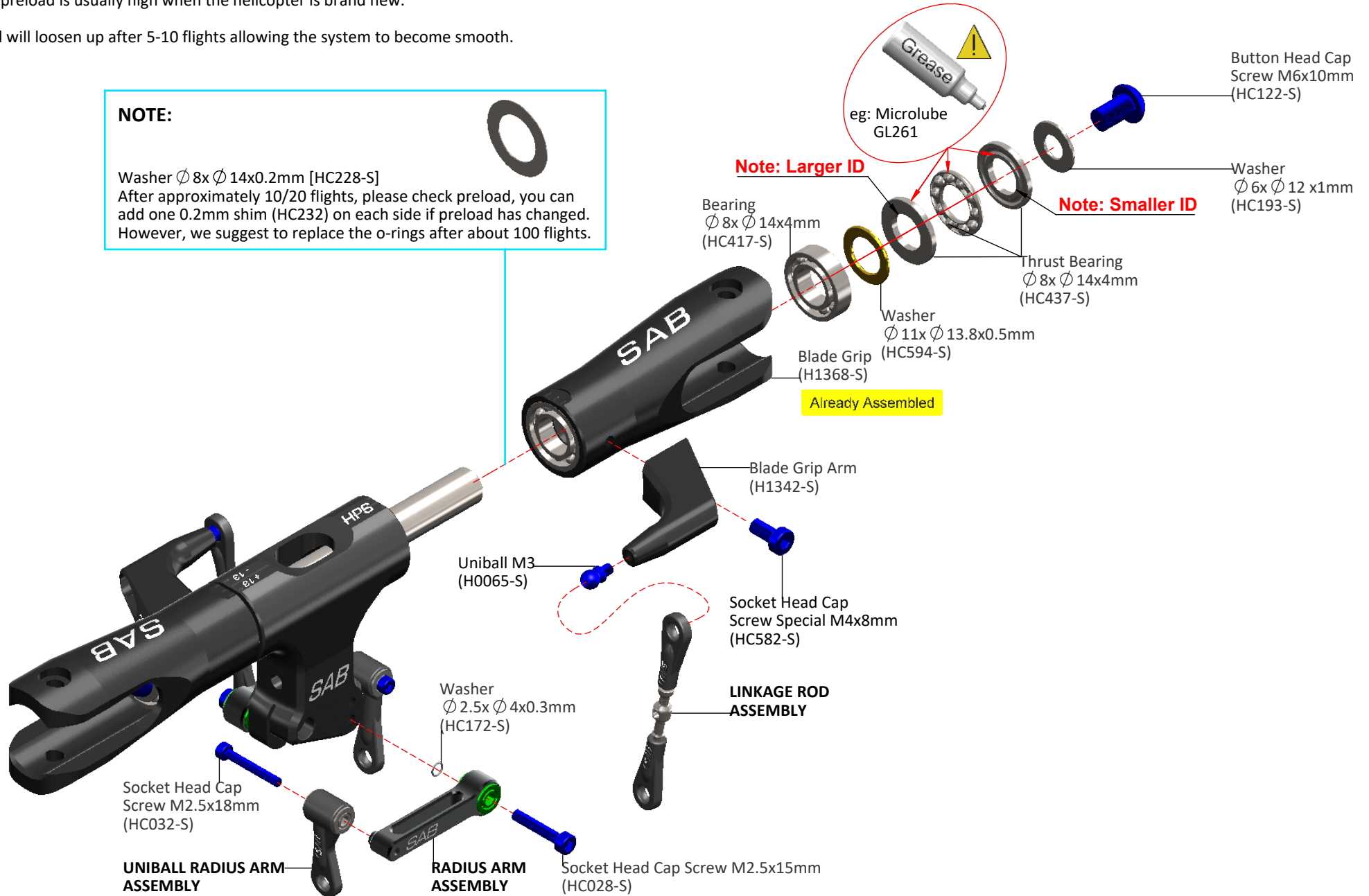

FOAM 2, BAG 1 1

It is normal for the tail to feel a bit tight after initial assembly as the tail spindle preload is usually high when the helicopter is brand new. The preload will loosen up after 5-10 flights allowing the system to become smooth.

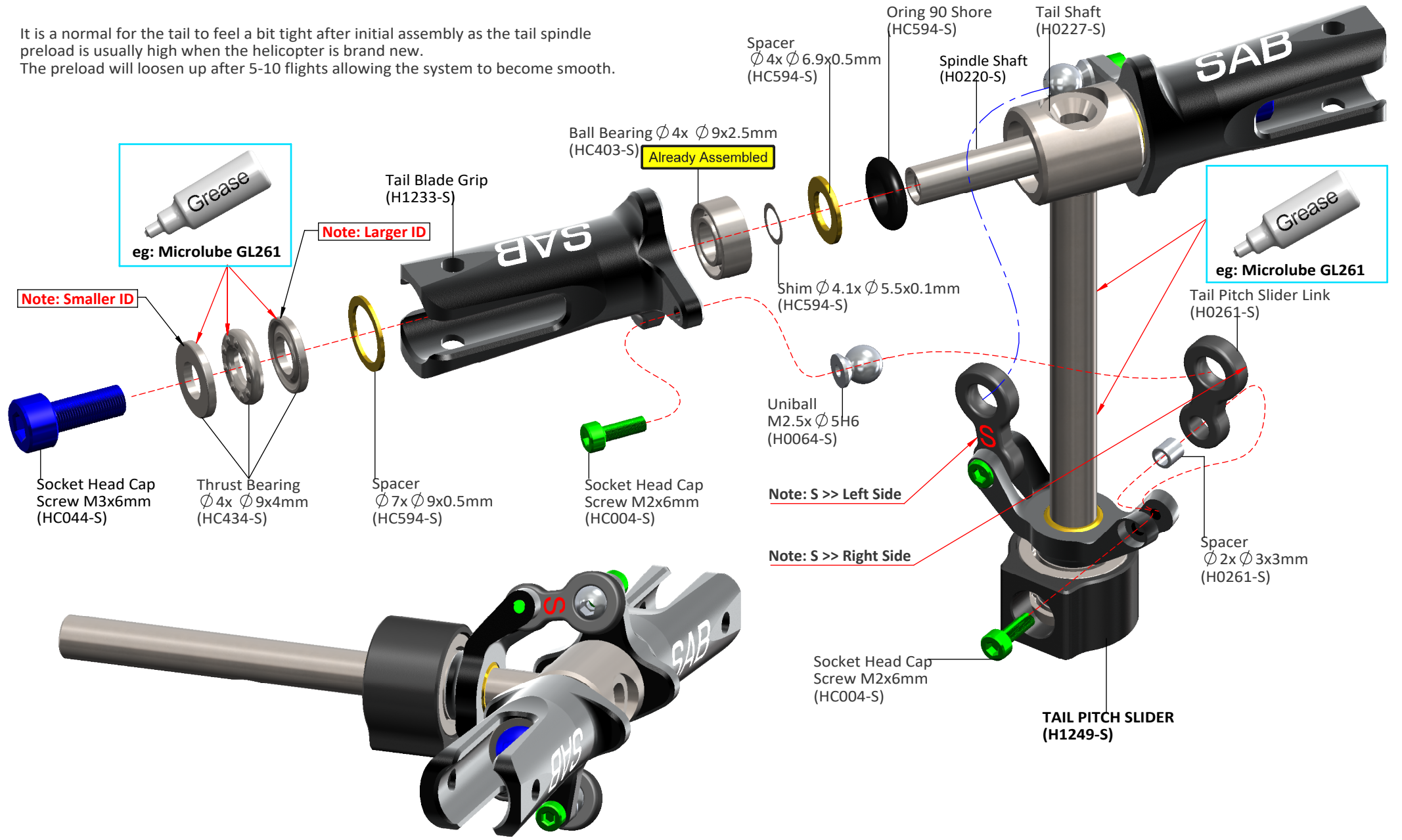

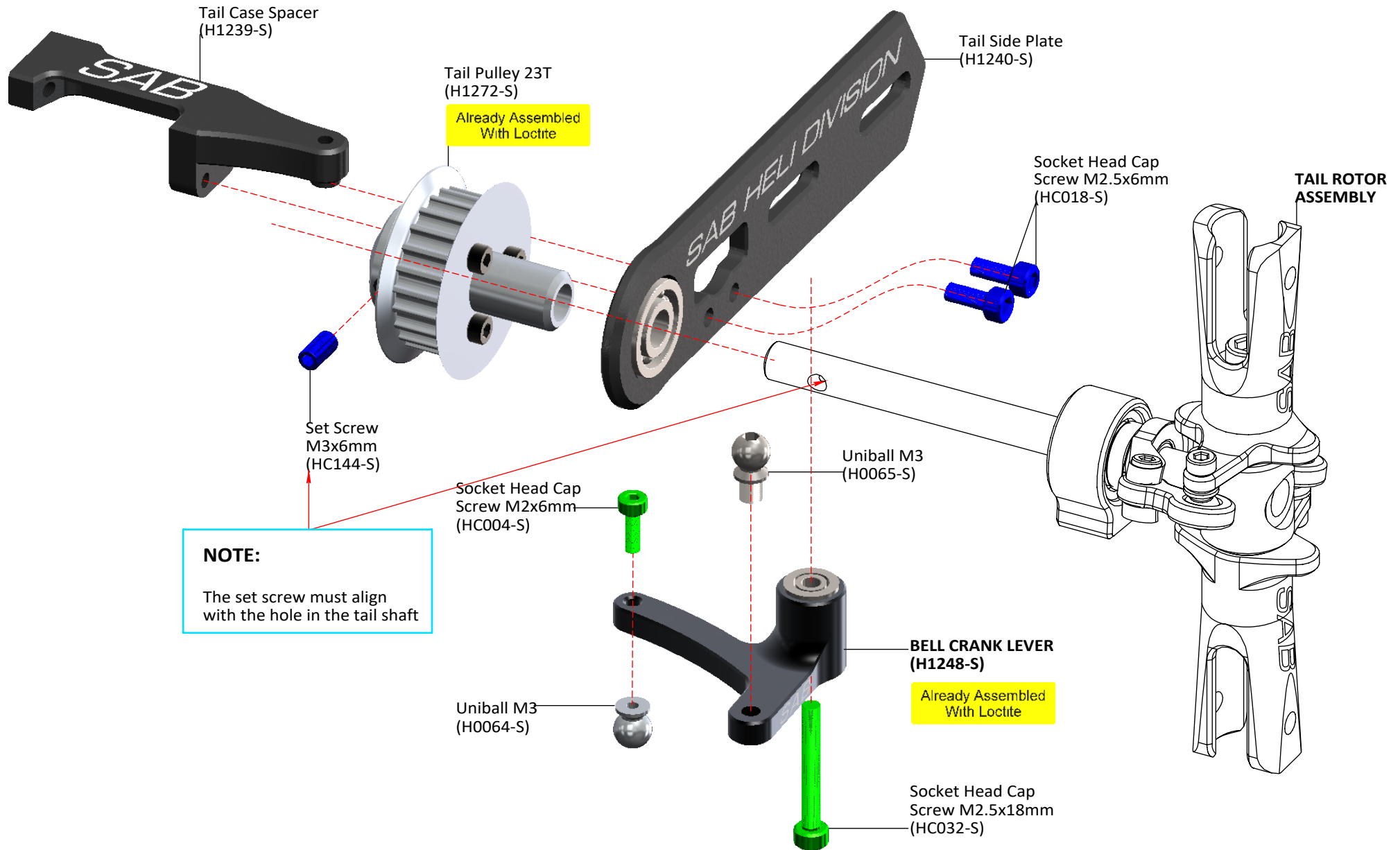

BAG 13

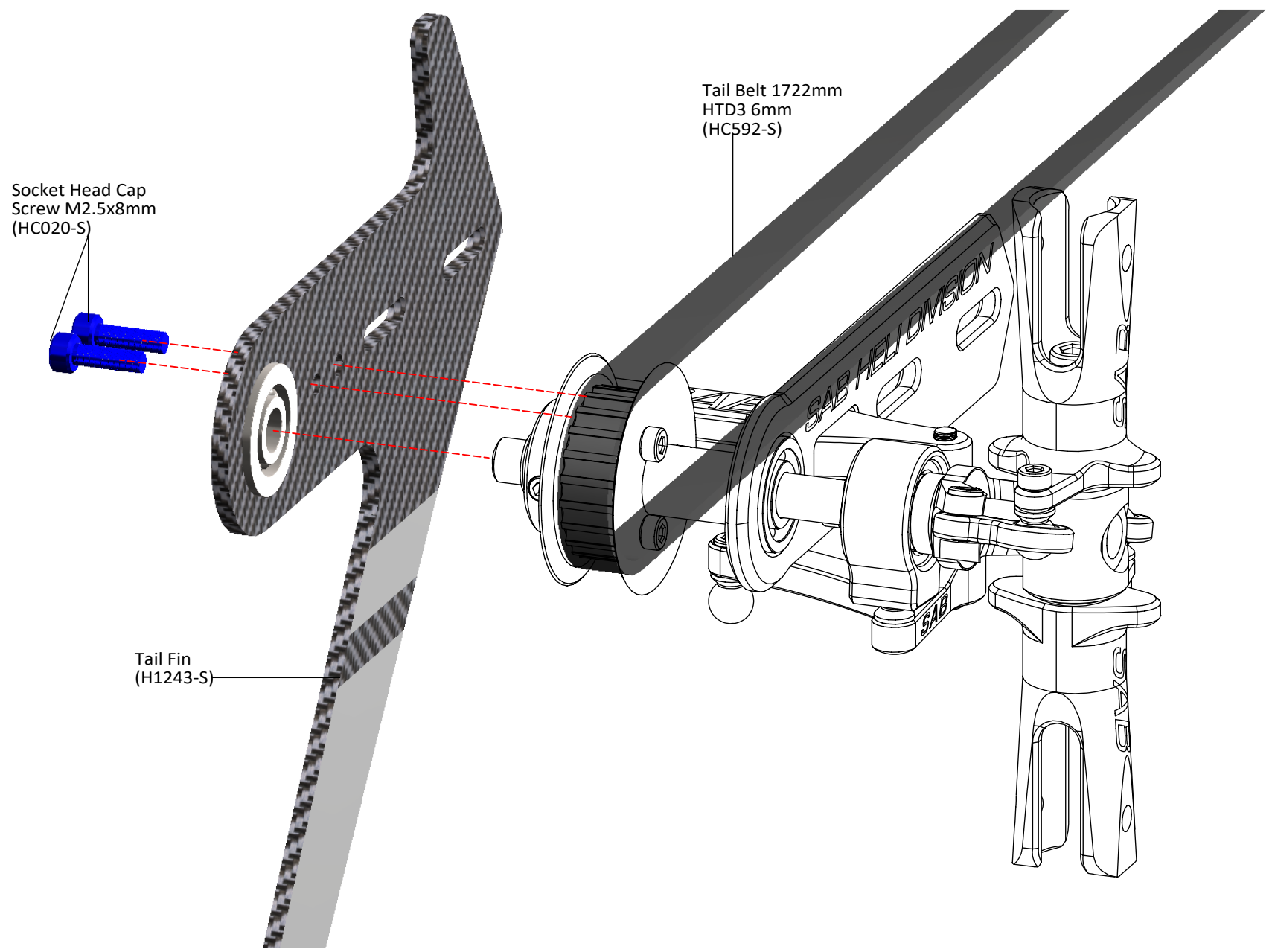

1

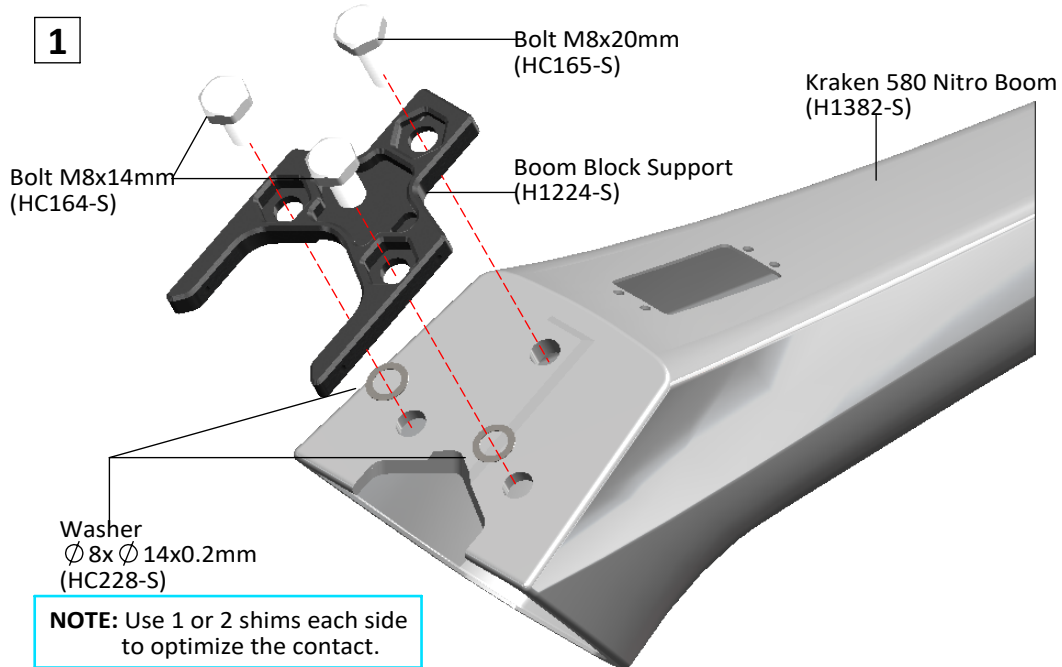

NOTE: Use 1 or 2 shims each side to optimize the contact.

2

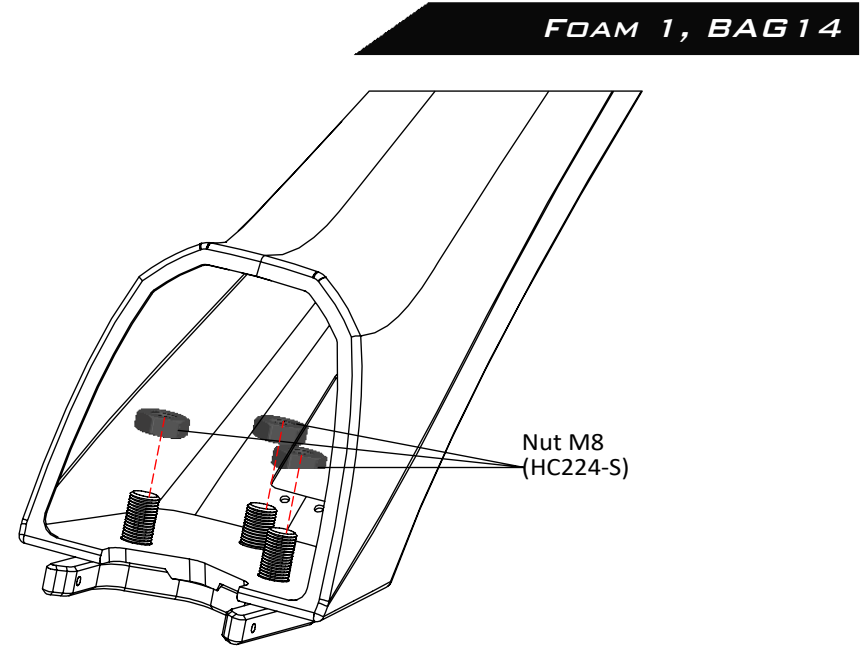

3

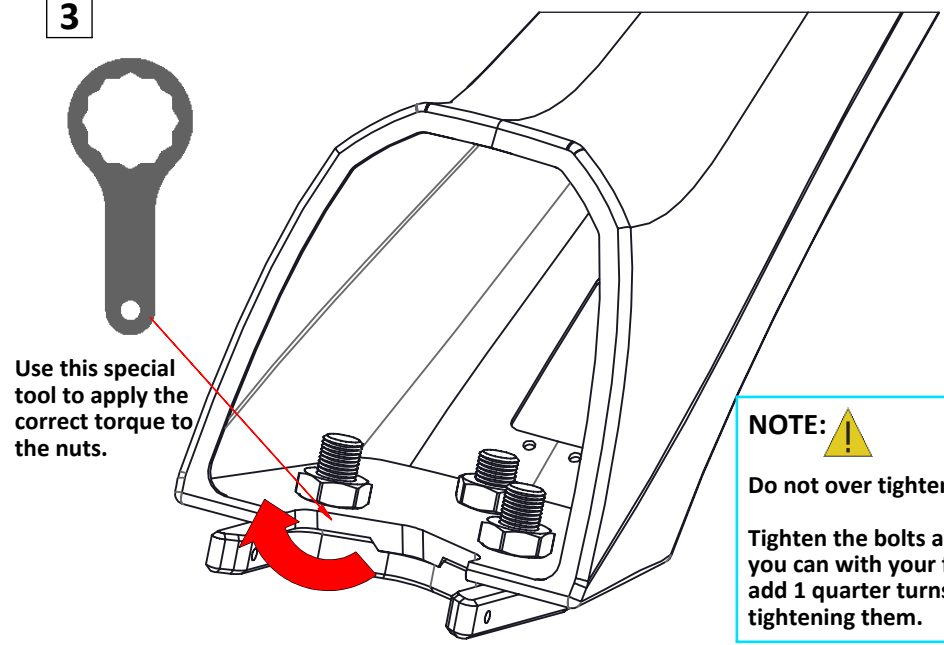

NOTE: ⚠
Do not over tighten the nuts.
Tighten the bolts as tight as you can with your fingers, then add 1 quarter turns to finish tightening them.

4

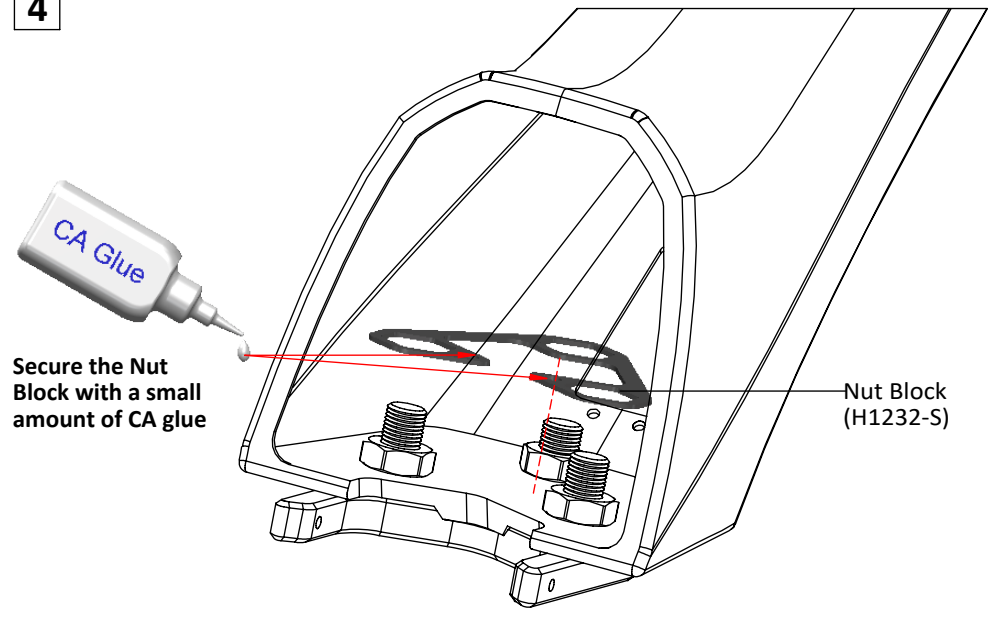

BAG 15

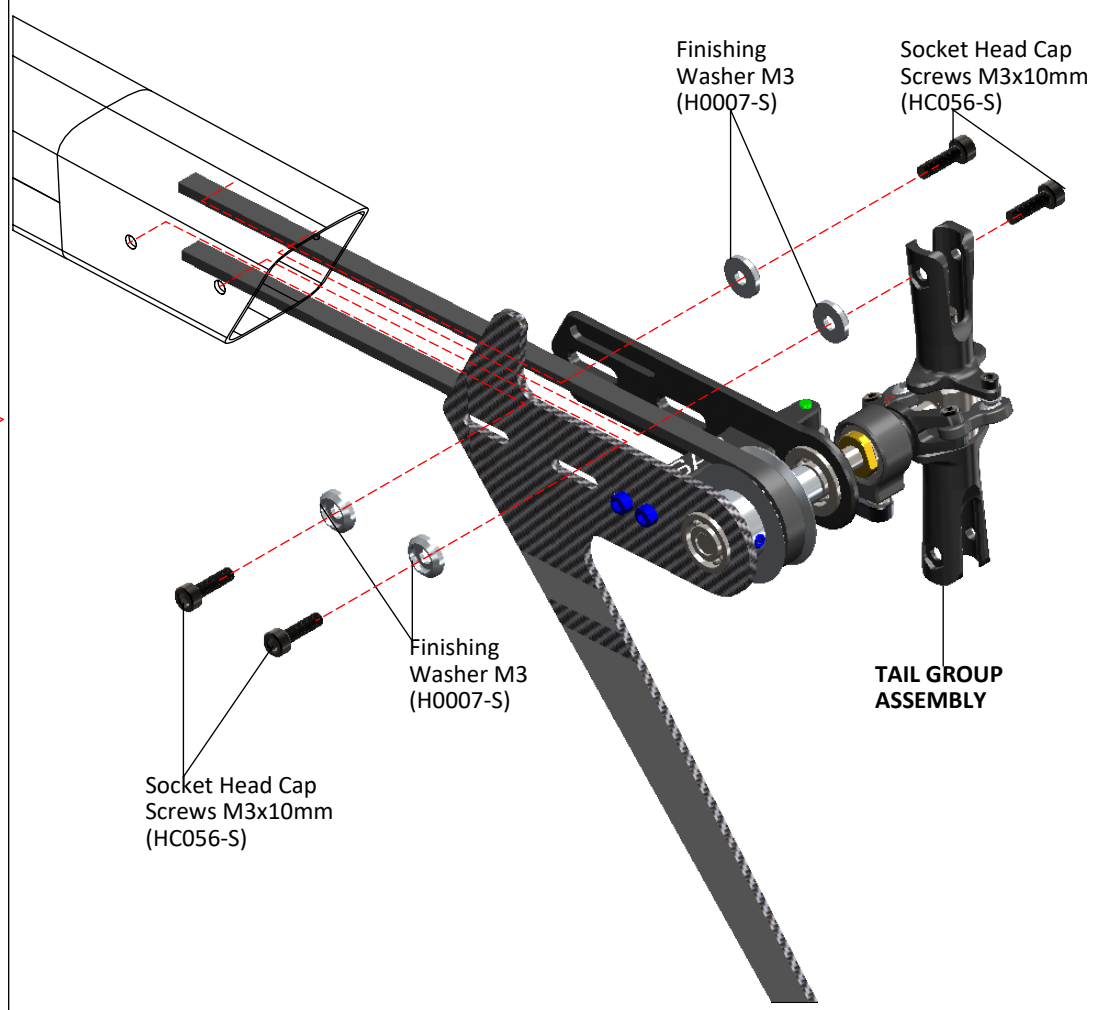
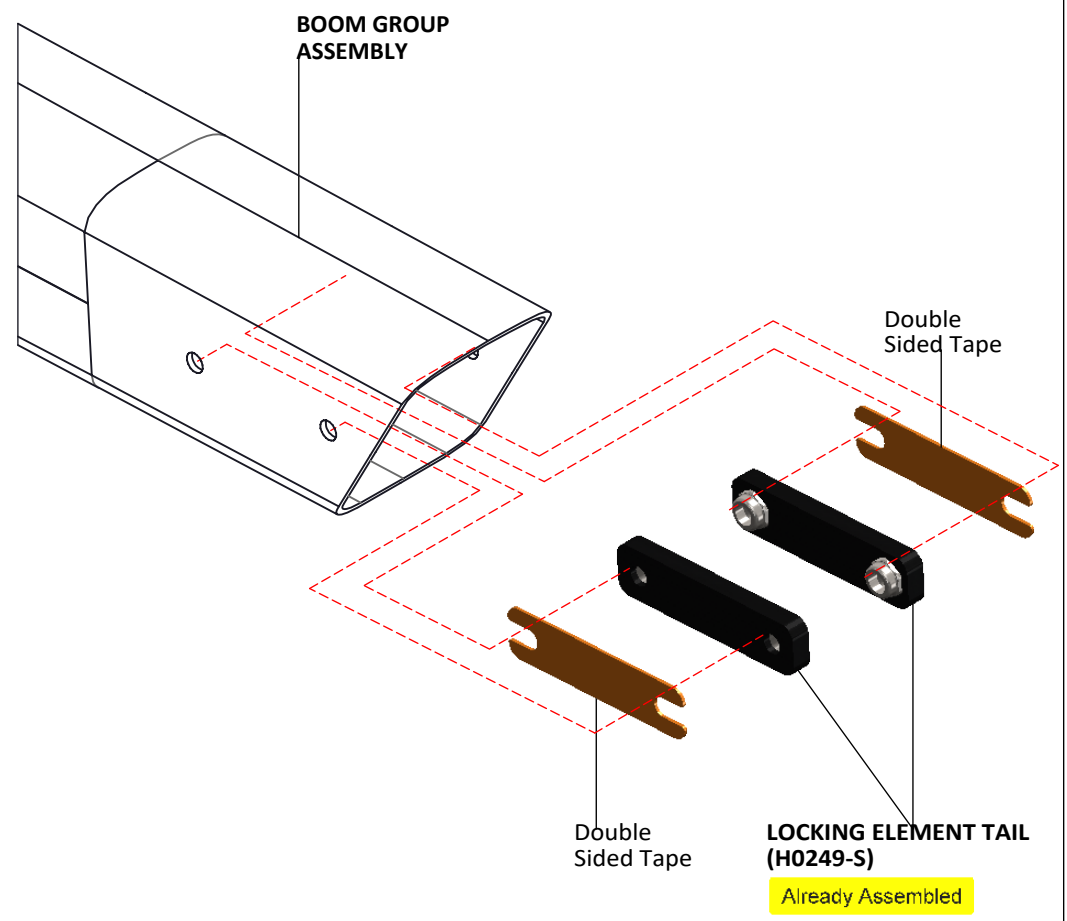

TAIL SERVO ASSEMBLY

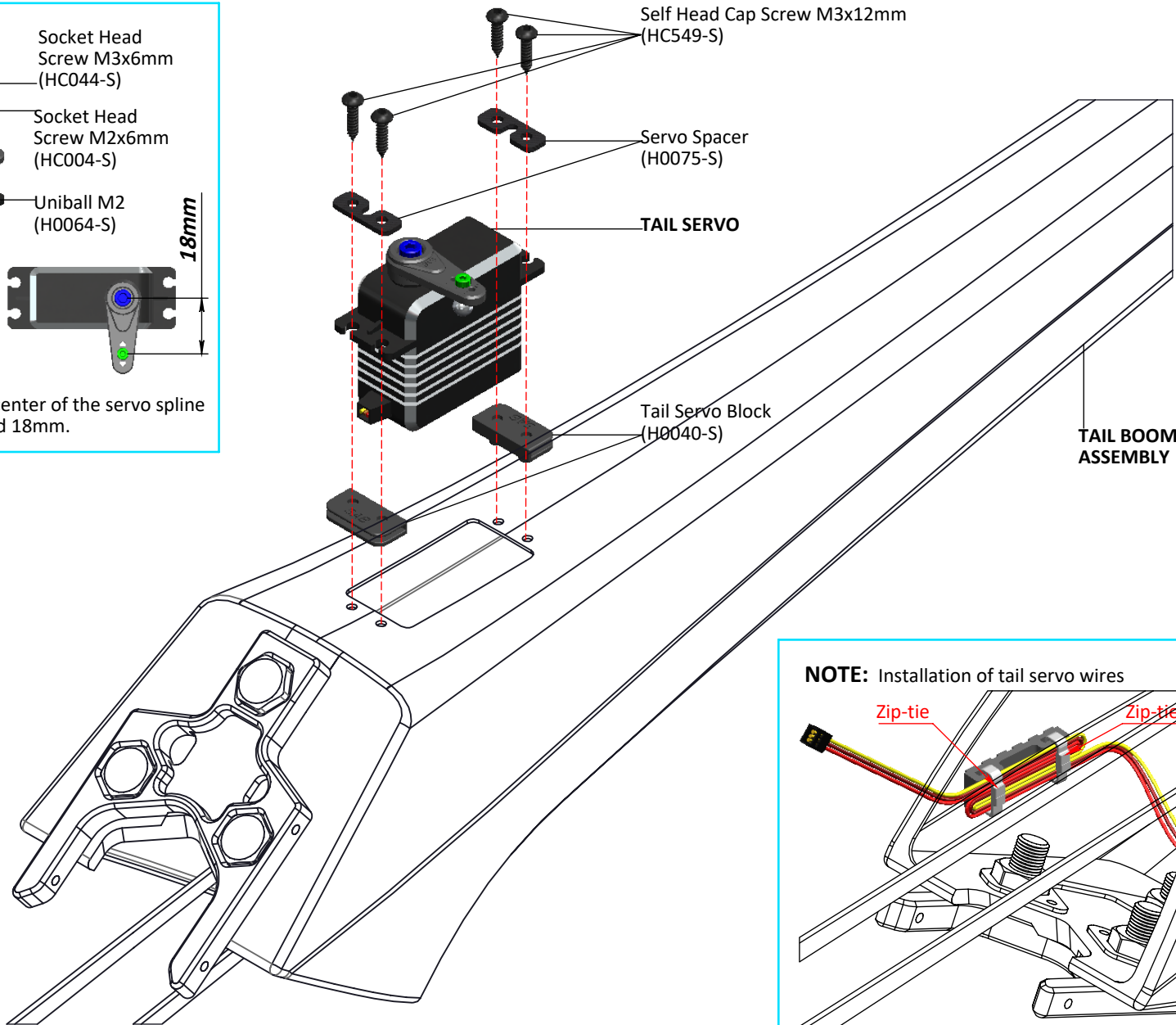
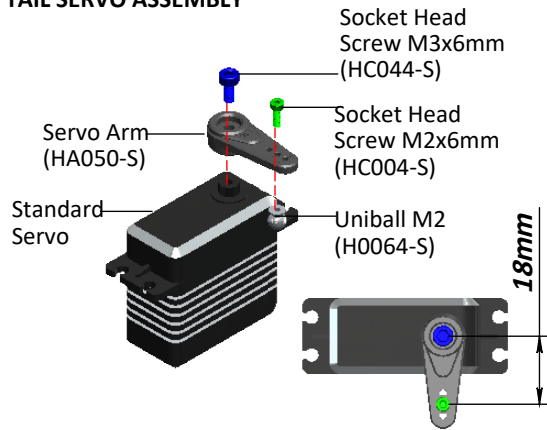

NOTE: Installation of tail servo wires

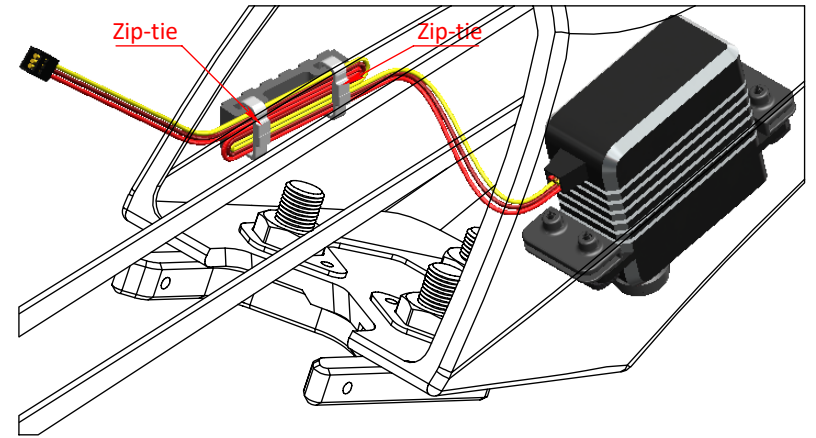

 Before installing the plastic link on the threaded rod, be sure that you have waited at least 12 hours for the glue to fully cure.

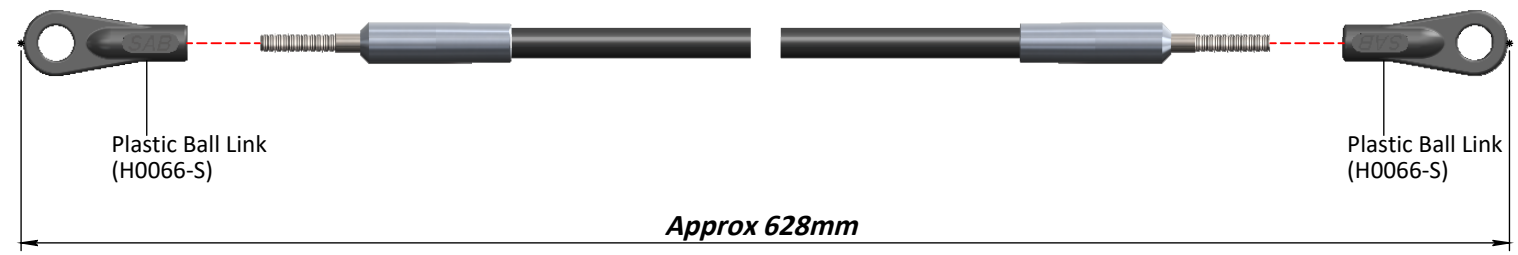

NOTE:
Before installing the plastic link onto the ball, be sure the tail push rod moves smoothly. You can open up H1315-S if you need to.

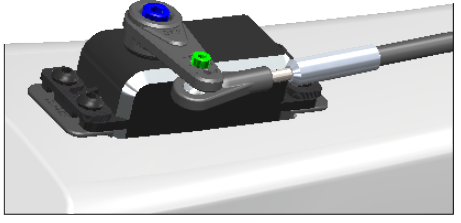

NOTE:
The carbon rod is slightly bent, generating a little preload against the carbon rod support. Check the movement of the rod. If it is a little tight you can enlarge the hole of the carbon rod support using a 5mm shaft.

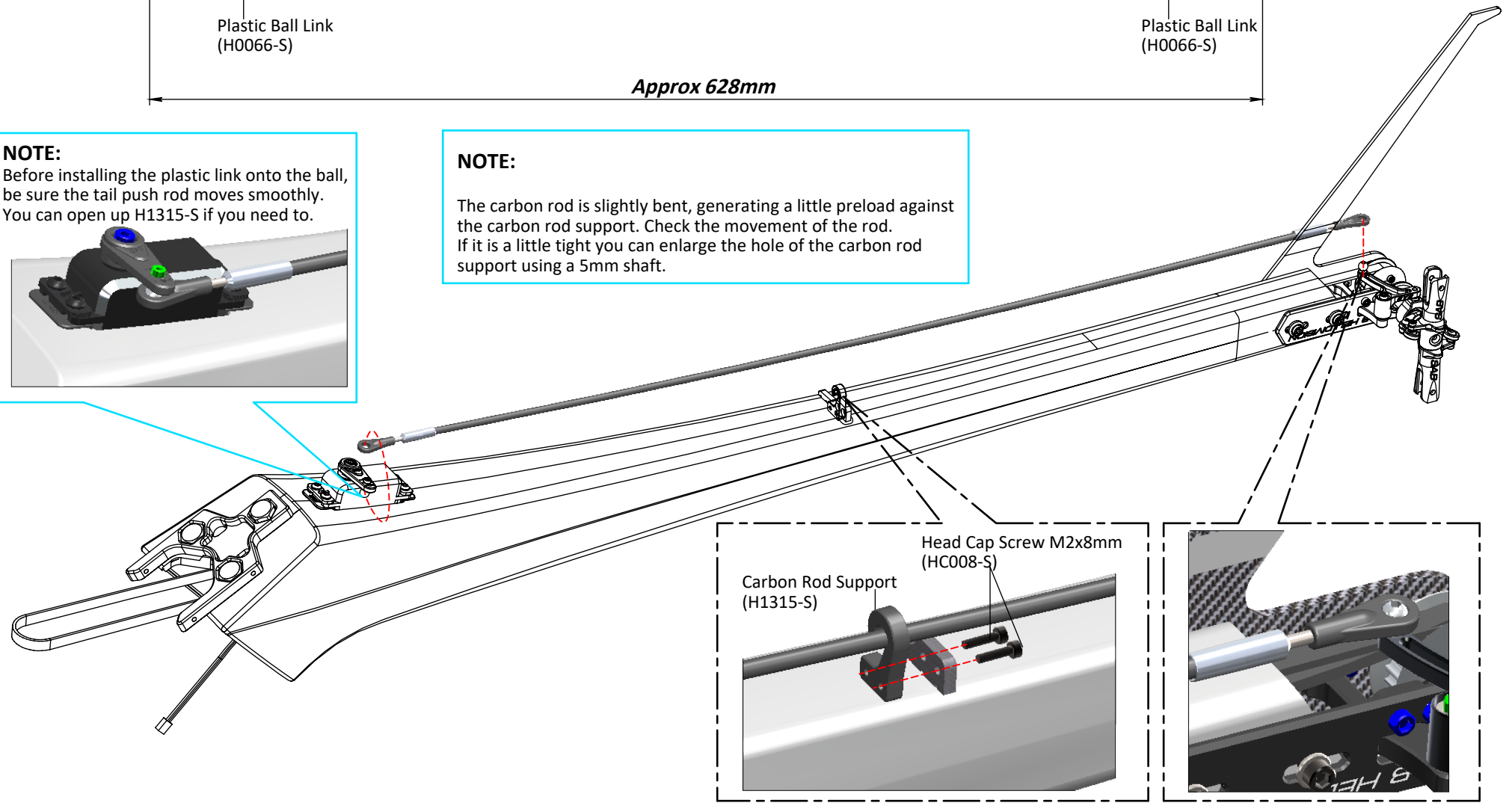

BAG 18

TIPS:
Using a 4/5mm shaft, you can tension the motor belt. Push the shaft on right side and then tighten the bolts.

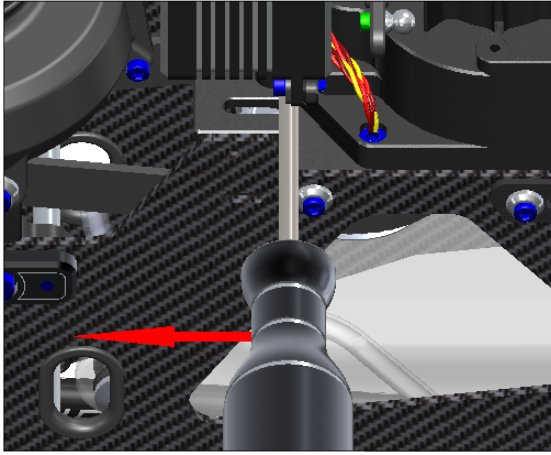

Don't install this screw at this time.

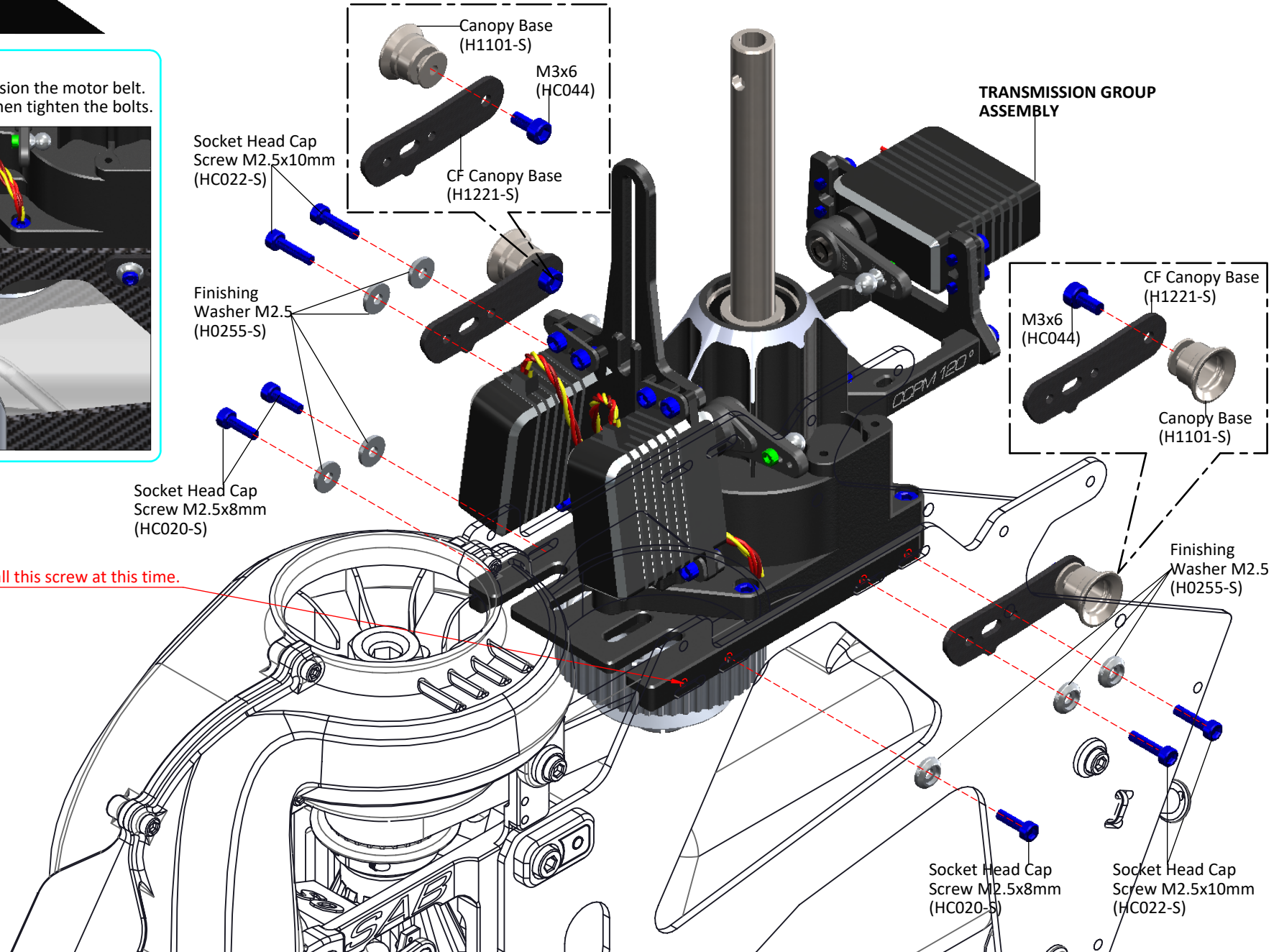

BAG 19, FOAM 2

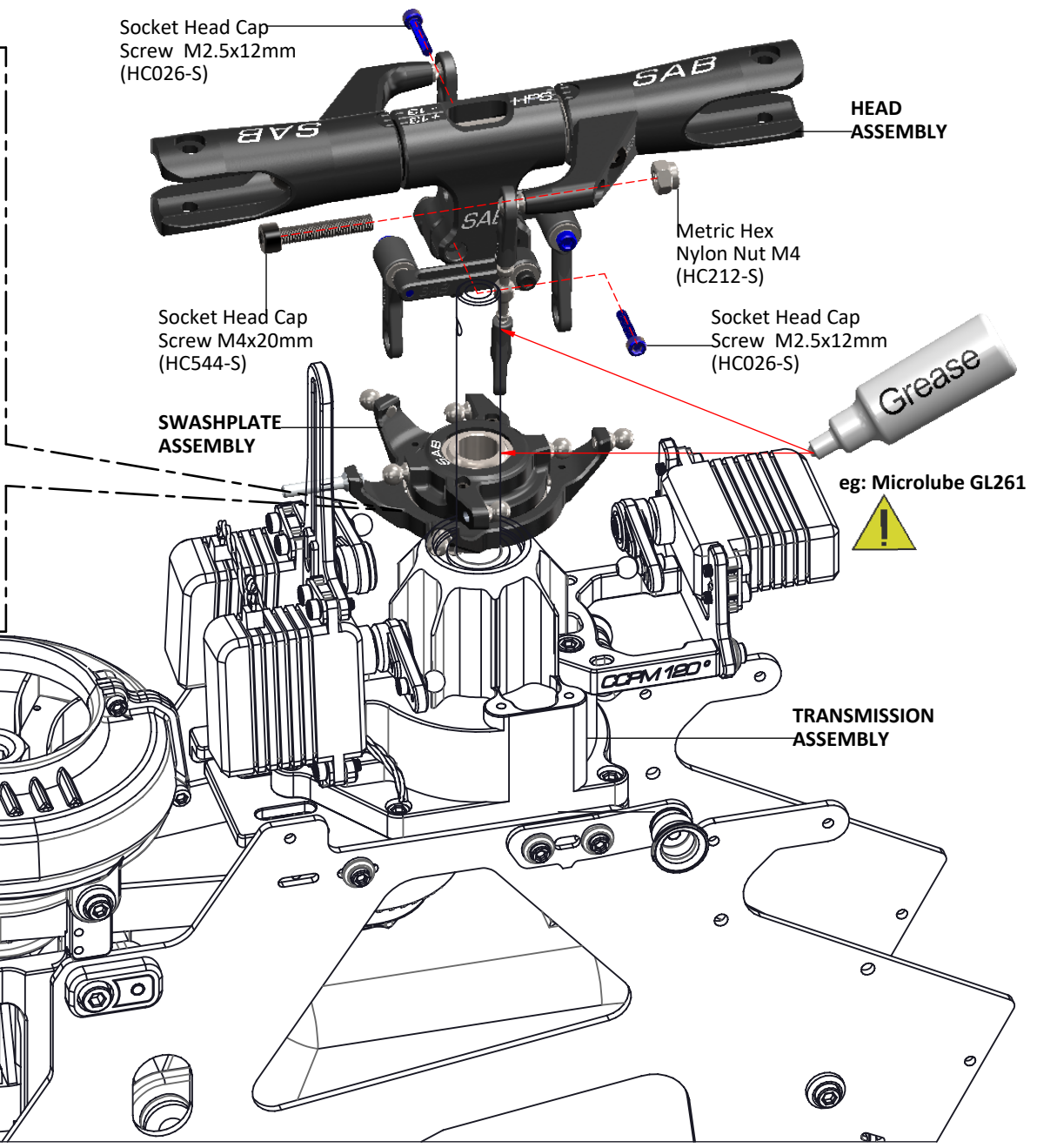
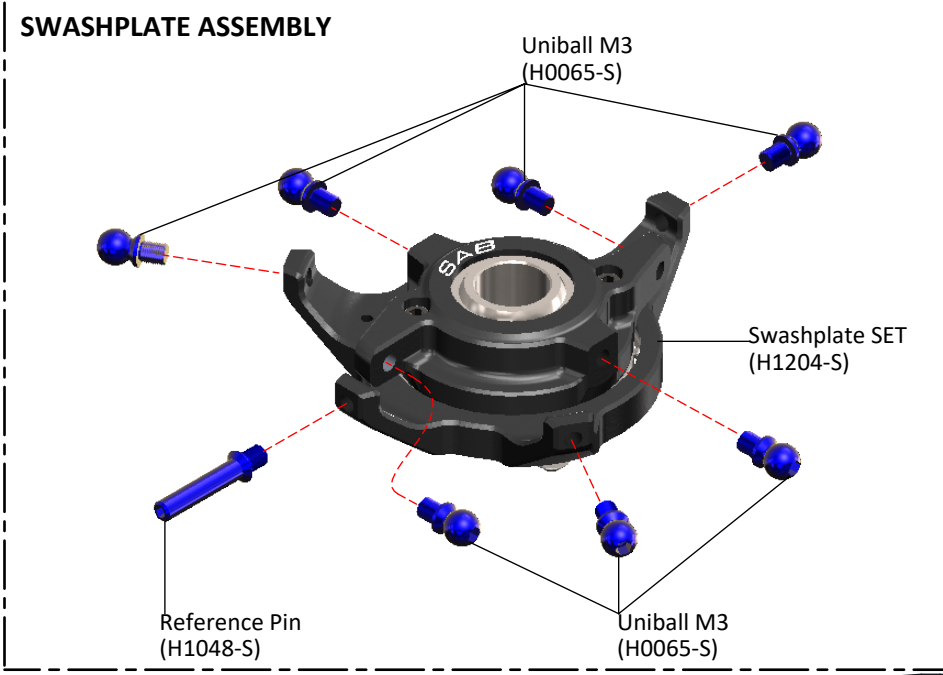

LINKAGE ROD ASSEMBLY ... x3

Approx 45mm

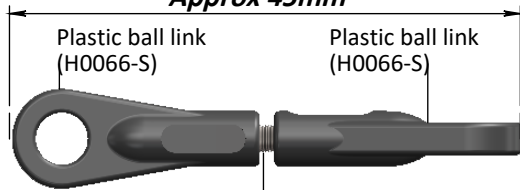

Set Screw M2.5x18mm
(HC140-S)

Initial length for the rods from the servos to the swash plate.

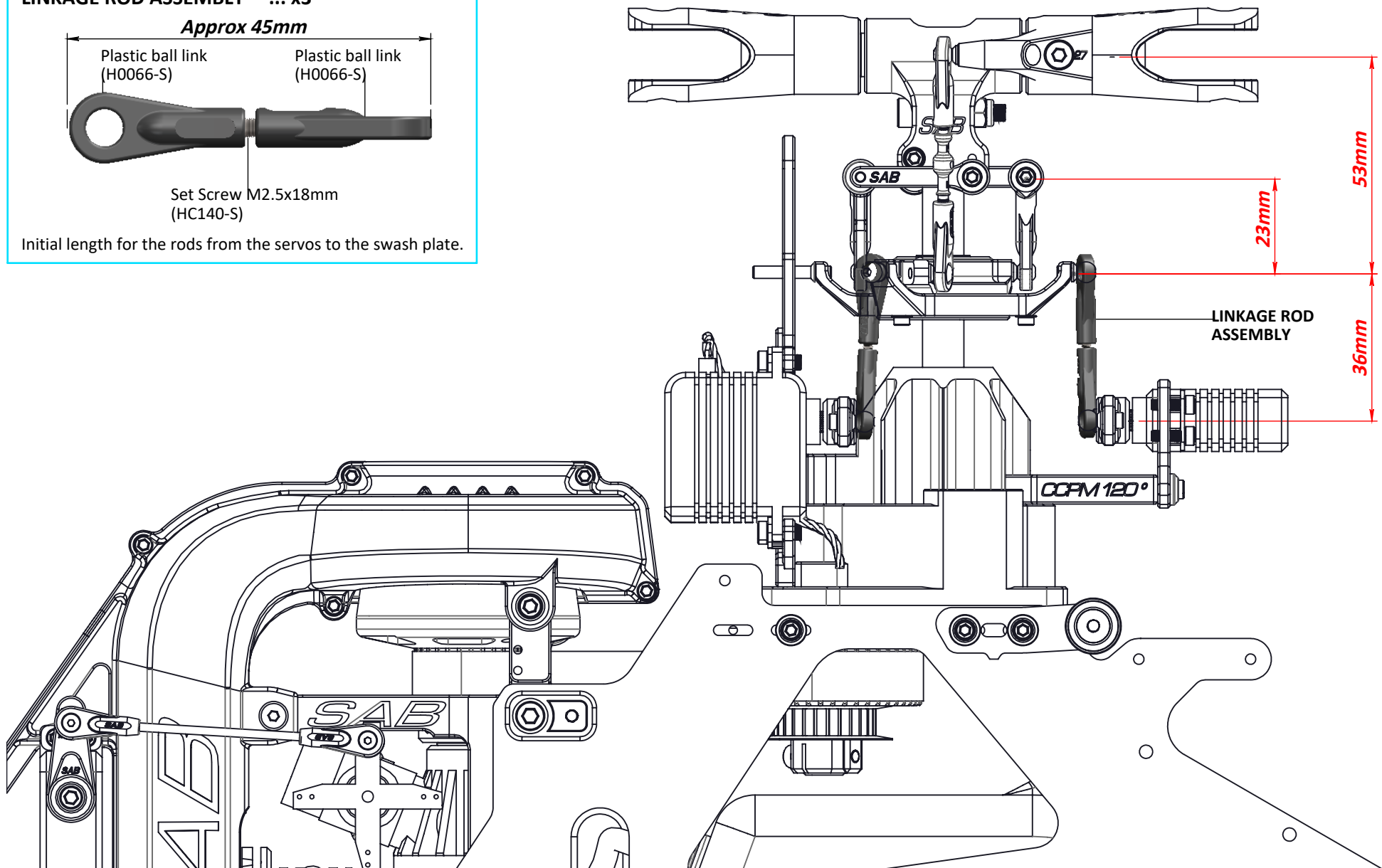

BAG 2 1

To fit the tail belt, loosen the tail case by loosening the 4 M3 screws (Figure 1).

- *Install the belt onto the tail front pulley, checking the direction of rotation.
- *Insert and tighten the four M3 screws in the boom plate.
- *Rotate the tail drive several times by hand.
- *Tension the tail case by hand and slowly tighten the 2 BLACK screws in (Figure 2).

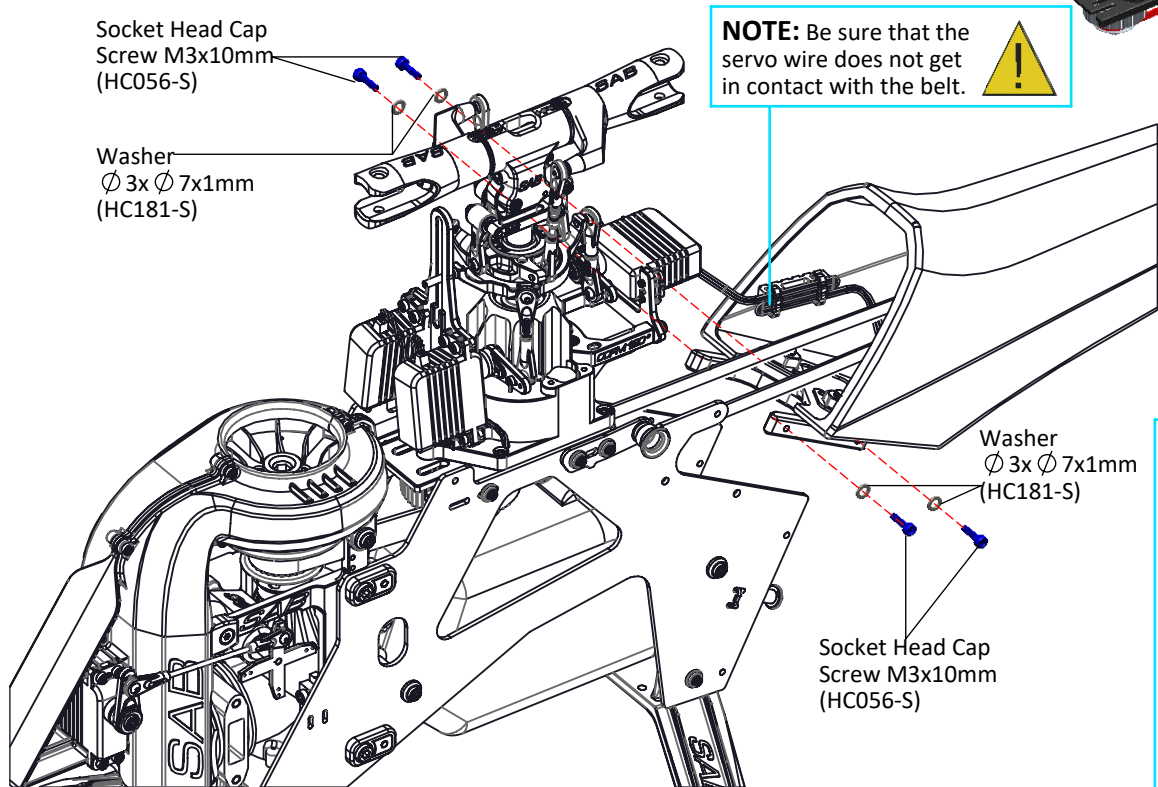
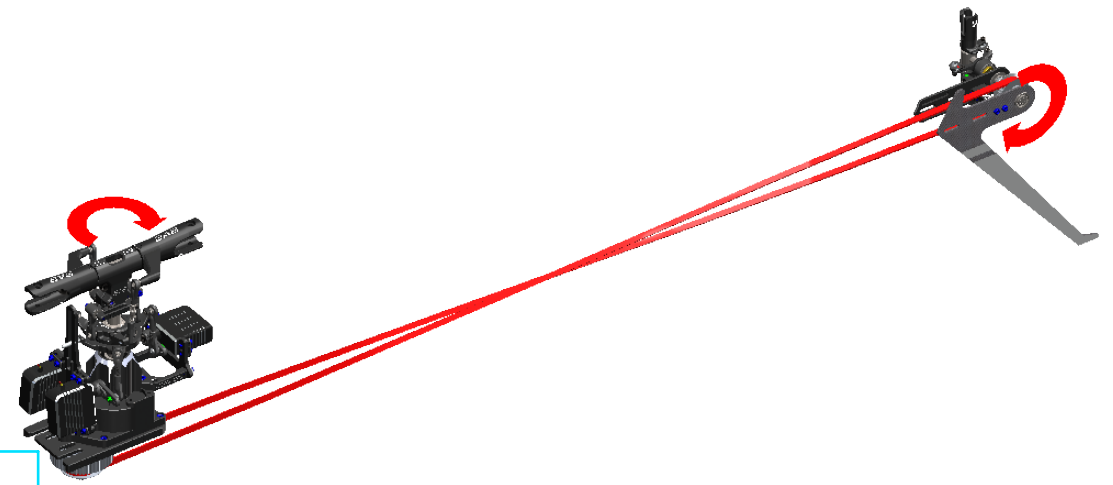

NOTE: Be sure that the servo wire does not get in contact with the belt.

NOTE: To disassemble the tail boom, you have to remove the 4 M3 screws. **DO NOT** loosen the 3 M8 plastic screw.

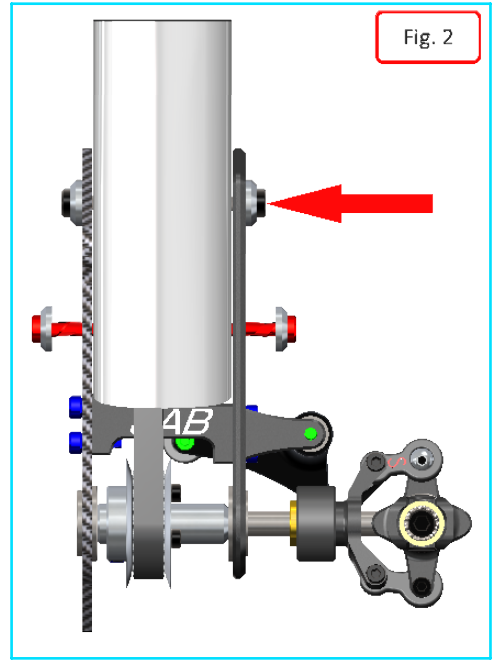
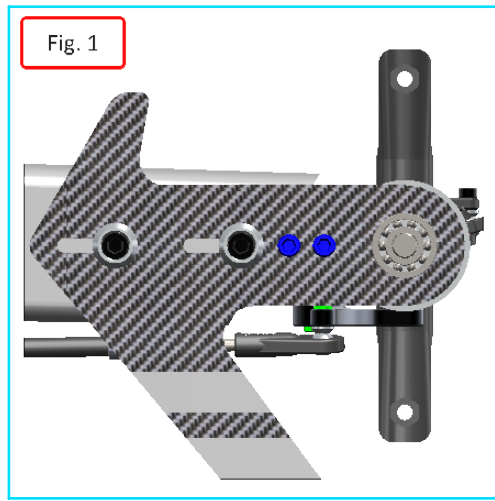

TAIL BELT TENSION

To provide the correct tail belt tension, you can use the "zig-zag" method.

Figure 1, Loosen the 2 **RED** screws and the **BLUE** and push the tail side plate in according with red arrow. Tighten the **BLUE** screw while you are pushing.

Figure 2, Loosen the 2 **RED** screws and the **YELLOW** and push the tail side plate in according with red arrow. Tighten the **YELLOW** screw while you are pushing.

You can proceed step by step until the tail belt is tight enough.

Hard 3D style will require more tension; Sport flight style less.

When you set your perfect tension, you can tighten all screws making sure the tail shaft is perfectly straight.

(**Figure 3**, tail output shaft must be perpendicular with the boom).

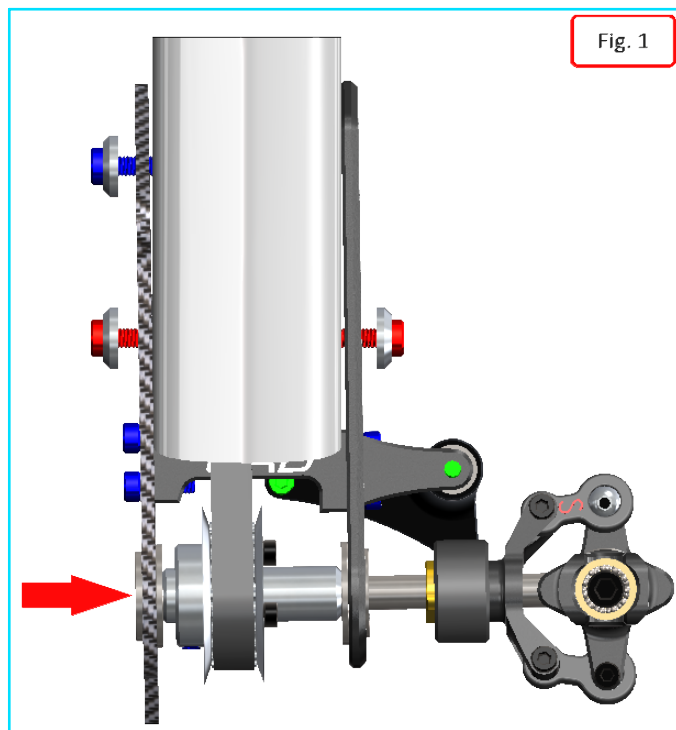

Fig. 1

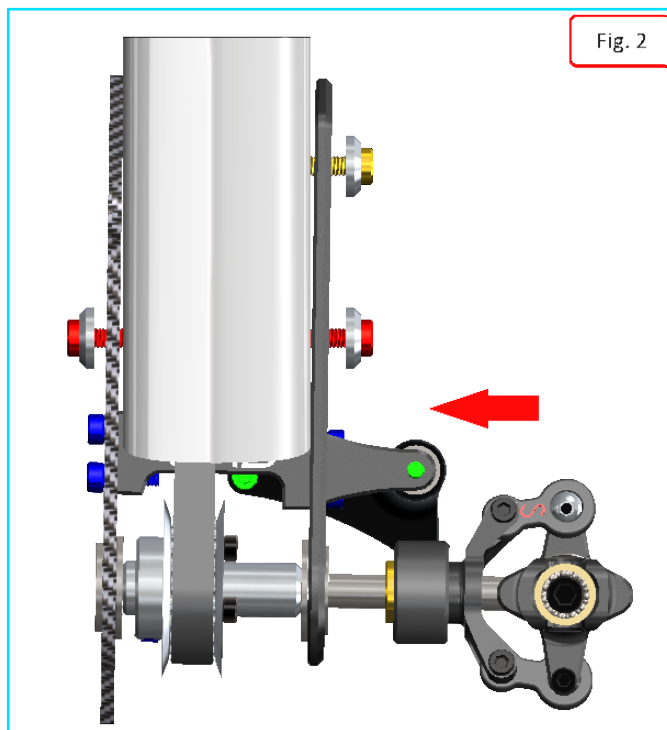

Fig. 2

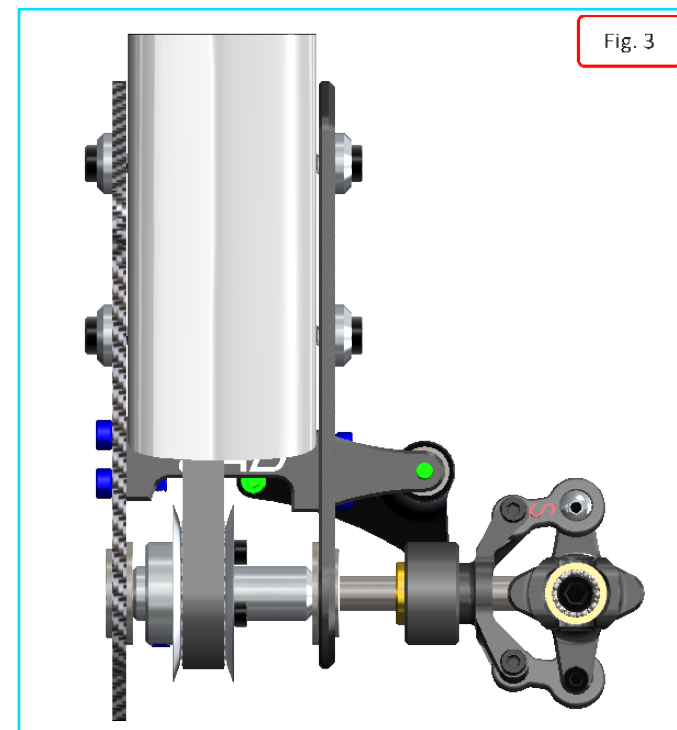
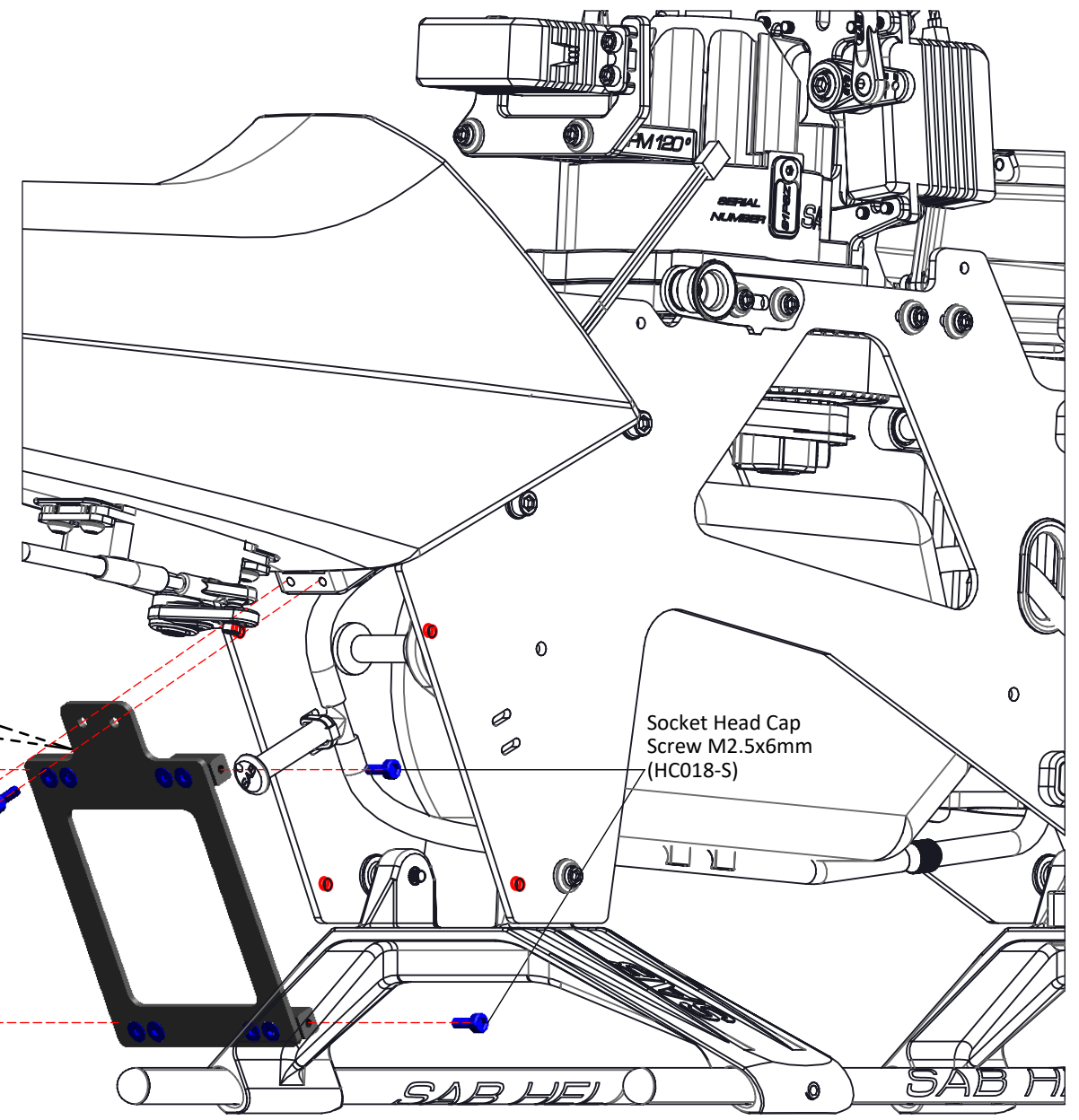
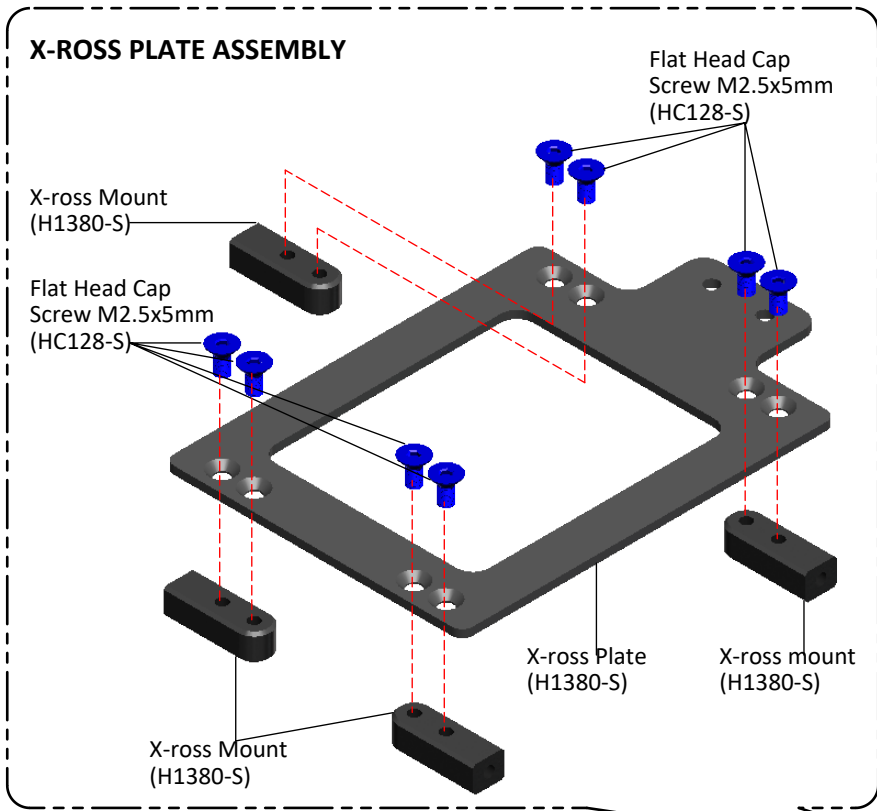
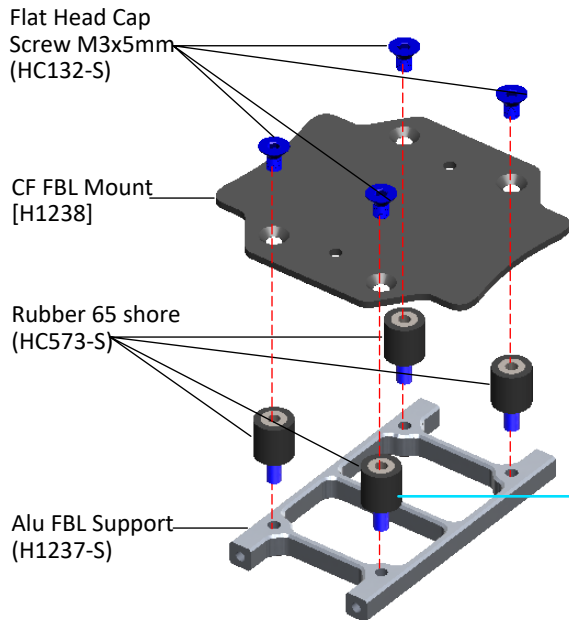
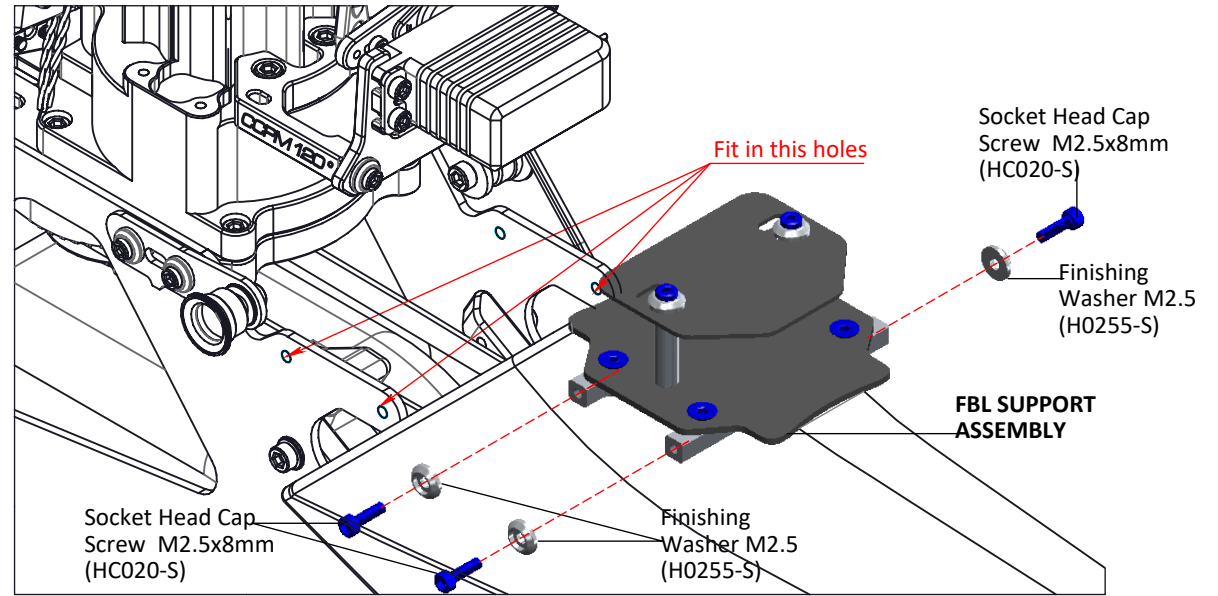
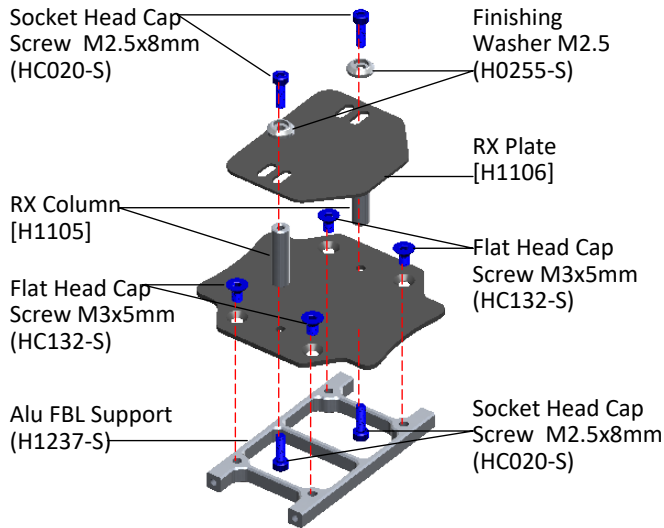

Fig. 3



We suggest installing the flybarless mount without the shock absorber. This will give you the most direct feeling of the model. You can use the small plate to support any separate RX.



RUBBER DAMPENERS

However, if you have issues with rescue feature of the FBL unit, you can use the rubber dampeners to reduce any kind of vibrations.

The sensor used for the RESCUE function is different from the flight management sensor. The filtration capability is different.

Our testing showed that the support system with the rubber dampeners can improve the filtering capability.

Normally the rescue function has a feature for checking the correct initialization. Verify the absence of anomalies.

By Using rubber dampeners it is not suggested to install the RX on the plate H1237.

The bottom surface of the rear servo is a good location to install an external RX (with double-sided tape).

NOTE:

Tighten the rubber dampeners with your fingers. No need to use tools.

Note: Use Thread Locker Medium Strength

BAGS 24.1, 28, 29

In bag 28, you can find a "3D Printed" antenna support. Use it as desired with your RX system.

Antenna Support [H1134]

Double Side-Tape (HA035-S)

EXTRA SUPPORT BAG 29

Flat Head Cap Screws M3x10 (HC135-S)

Battery Backup Support (H1241-S)

Nylon Nut M3 (HC206-S)

Socket Head Cap Screw M2.5x8mm (HC020-S)

Finishing Washer M2.5 (H0255-S)

CF Wire Support (H1383-S)

Nylon Nut M2.5 (HC200-S)

Socket Head Cap Screw M2.5x8mm (HC020-S)

Finishing Washer M2.5 (H0255-S)

Button Head Cap Screw Special M2.5x6mm (HC019-S)

Wire Support (H1107-S)

Finishing Washer M2.5 (H0255-S)

NOTE: You can wait to tighten this screw until after you run all of your cables.

Socket Head Cap Screw M2.5x8 (HC020-S)

NOTE: You will need to cut about 60mm off the front of the wire support.



NOTE: Use hot glue to secure the wire connections.

BAG24.2

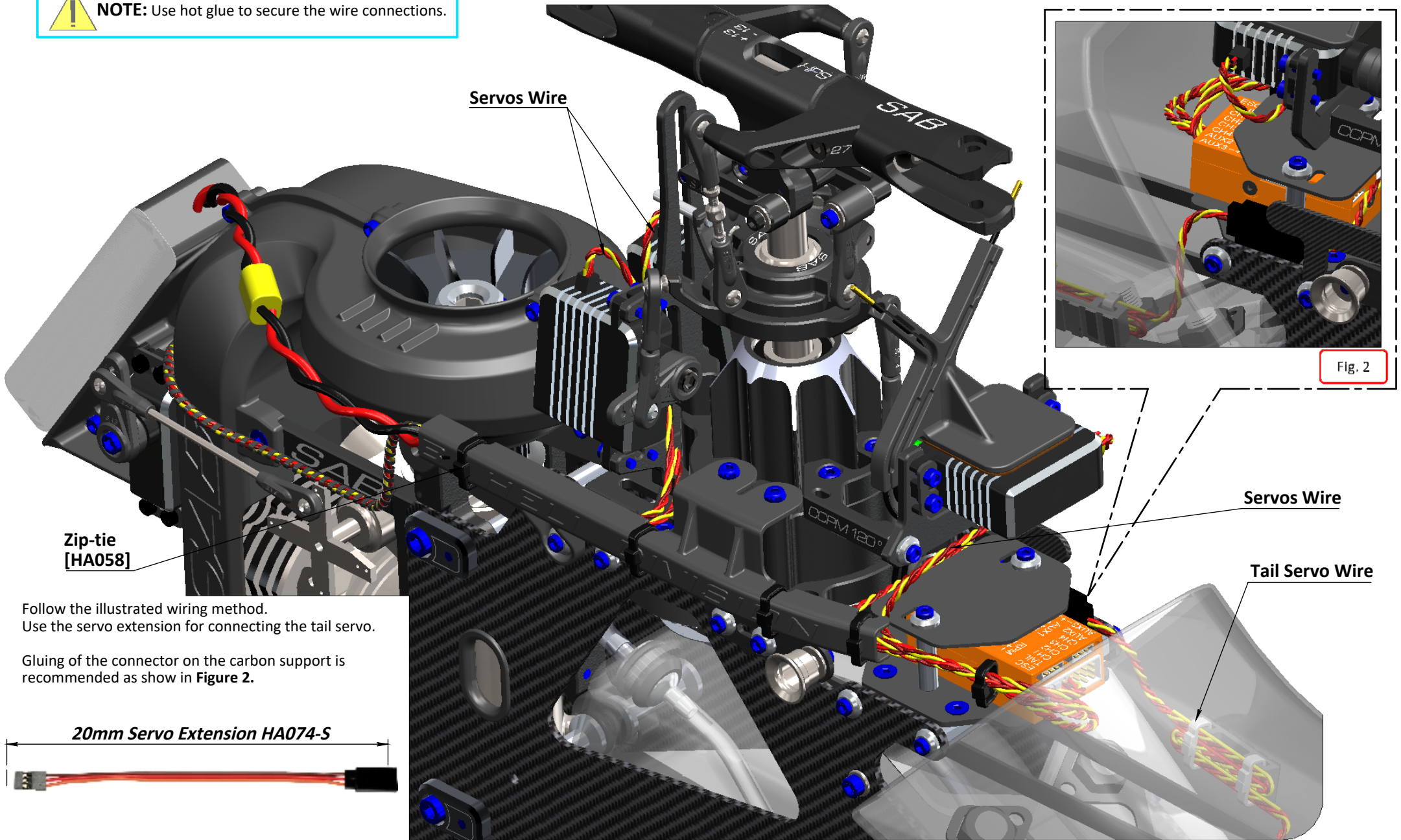

Follow the illustrated wiring method.
Use the servo extension for connecting the tail servo.

Gluing of the connector on the carbon support is recommended as show in **Figure 2**.

BAG25



Install the muffler before checking the CG. Adjust the battery position so that the CG is located on the main shaft.



BATTERIES

Use the included double side tape to secure the batteries to the tray.
Use the Velcro Strap [HA044-S].

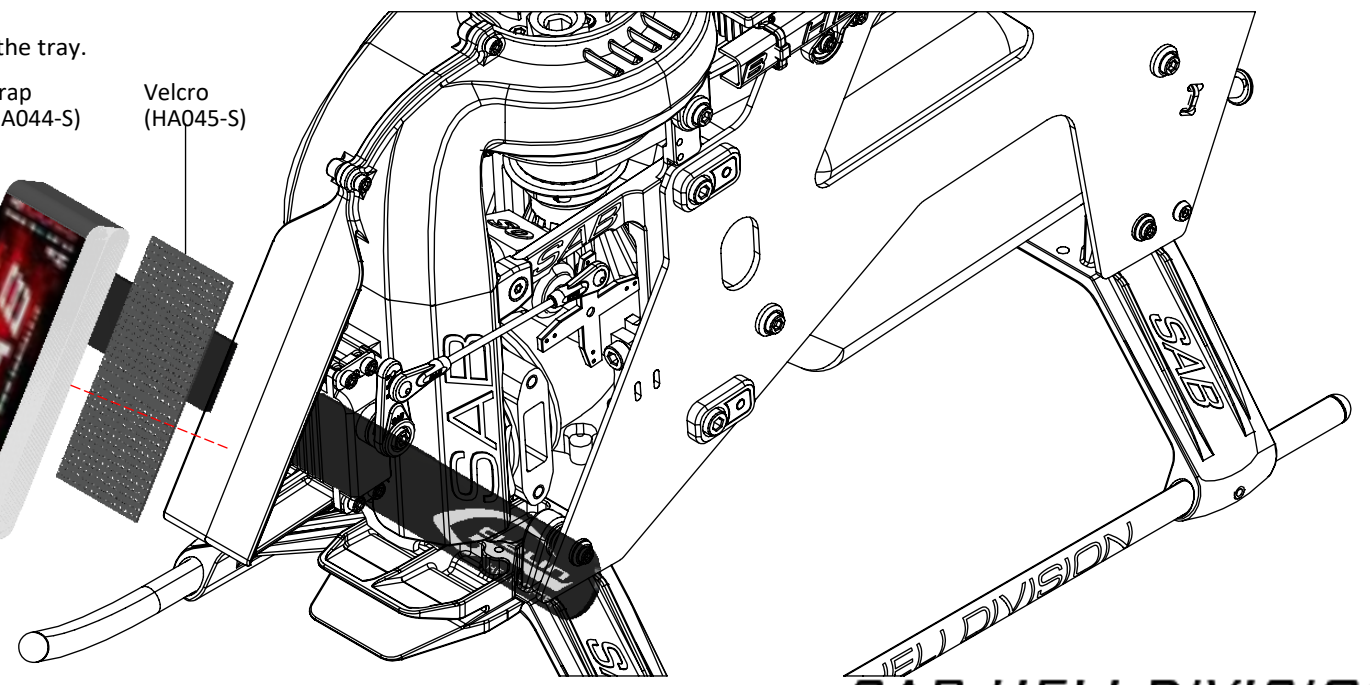
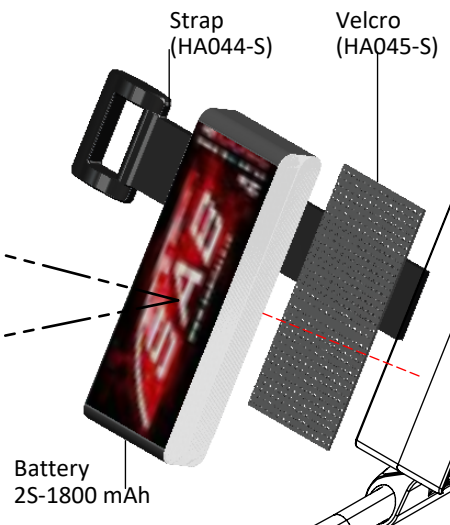

CANOPY

*Install Canopy grommets (**Figure.1**) and the two quick knobs (**Figure.2**)

*Fit the canopy in the red arrow zone, and insert the knobs.

 *Confirm the canopy is secure prior to each flight.

Kraken 580
Nitro Canopy
(H1381-S)

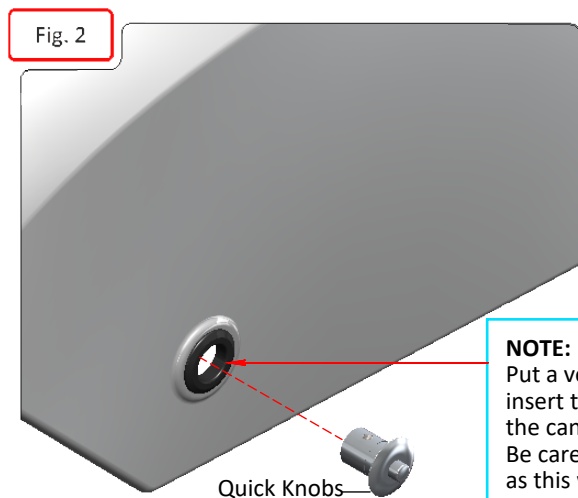
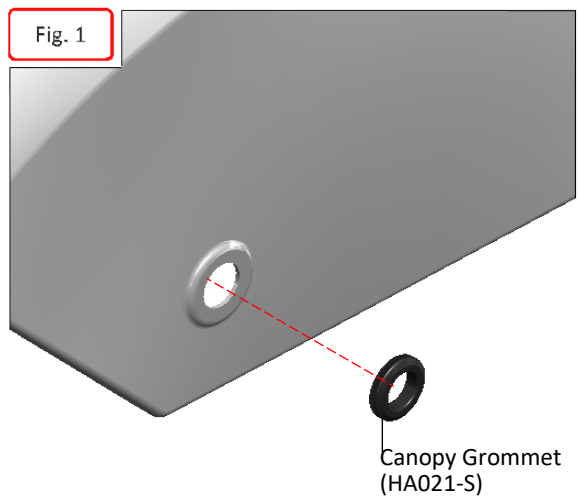

NOTE:
Put a very small drop of CA glue on the grommets and then insert the quick release canopy mounts. Doing so will prevent the canopy mounts coming off when removing the canopy. Be careful not to get CA glue on the quick release mechanism as this will affect the operation of the mechanism itself.

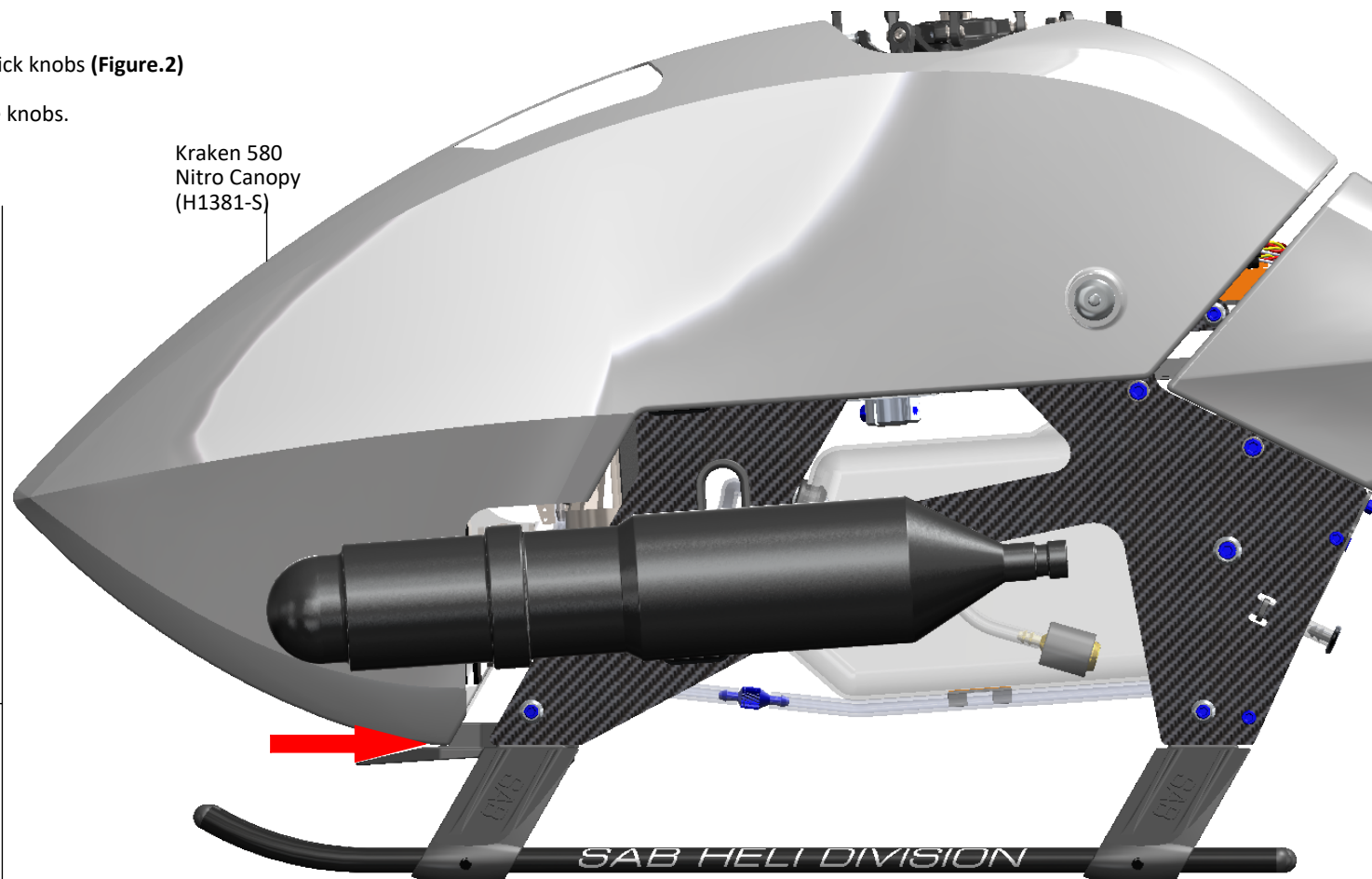

NOTE: To keep the canopy perfectly centered on the helicopter, you can add 2 strips of 4mm foam to the fan shroud.

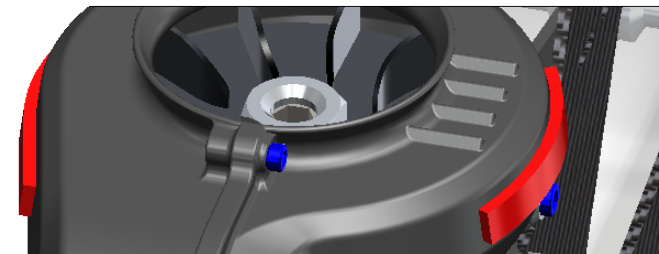

BAG27

OPERATIONS BEFORE FLIGHT

- *Set up the remote control and the flybarless system with utmost care.
- *It is advisable to test the correct settings of the remote and flybarless system without main blades or tail blades fitted.
- *Check that all wiring is isolated from the carbon/aluminum parts. It is good practice to protect them at the points where they are at most risk.
- ***Be sure of the gear ratio, verifying carefully the motor pulley in use. The forces acting on the mechanics increase enormously with increasing of rpm. Although the Goblin can fly at high rpm, for safety reasons we suggest to not exceed 2600rpm (2500 rpm with 600mm main blades configurations).**

- *Fit the main blades and tail blades. (Figure.1 and Figure.2)
- *Please make sure the main blades are tight on the blade grips, you should be able to violently jerk the head in both directions and the blades should not fold. Failure to tighten the blades properly can result in a boom strike. To fold the blades for storage, it is advisable to loosen them.
- *Check the collective and cyclic pitch. For 3D flight, set about +/-13°.
- *It is important to check the correct tracking of the main blades.
- On the Goblin, in order to correct the tracking, adjust the main link rod. This is provided with a right/left thread system that allows continuous fine adjustments of the length of the control rod; for this adjustment it is not necessary to detach the ball link.
- *Confirm the canopy is secure prior to each flight.
- * Make sure that the battery locking pin is back in its resting position, blocking in correct way the battery tray.

- ***Perform the first flight at a low headspeed, 2000 RPM.**
- ***After this first flight, do a general check of the helicopter. Verify that all screws are correctly tightened.**

IN FLIGHT ABOUT HEAD

The HPS head allows for a very broad range of dampening setups (Figure 3). The dampers are composed of 2 O-ring (that defines the rigidity) and a technopolymer damper (that defines the maximum possible movement of the spindle). Using different Oring and dampers you can get different responses of the model.

Oring

- 70 Shore: Soft for smooth response
- 90 Shore: Firm for direct and precise response
- A = Max movement of the spindle, feeling more elastic.
- B = Medium.
- C = Min movement of the spindle, feeling more direct.

The kit includes B damper (Spare parts H1216-S).
[All Setting >>p/n H1216-S].

ABOUT THE TAIL

The standard SETUP is optimized for 3d flight, headspeed 2400-2600 rpm. If you prefer flying at low speed (< 2200 rpm), for best results we recommend changing the tail pulley to increase tail rotor rpm. In this way, you will have extremely precise tail control even at low RPM. This pulley is available in the upgrade list [H0310-S]
If you want to fly under 2000 rpm, we suggest to use bigger 105 mm tail blades.

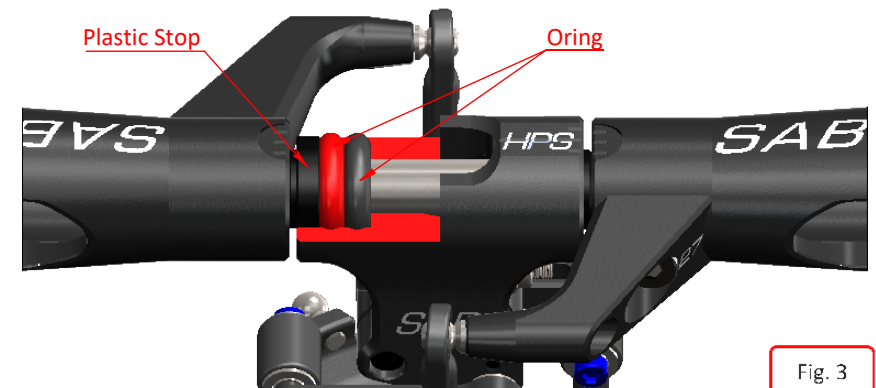
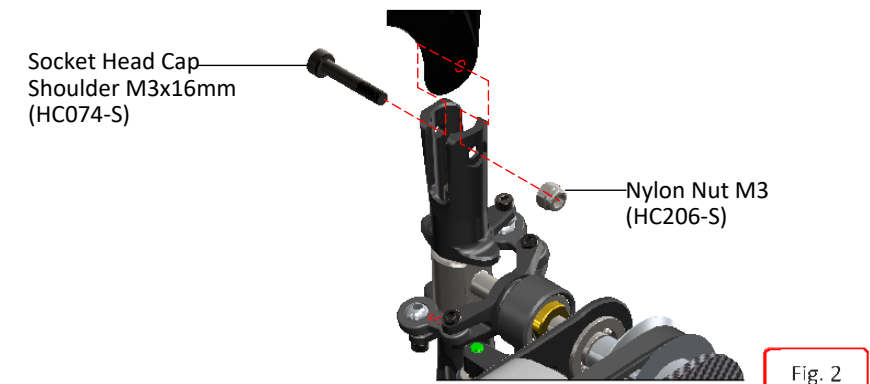
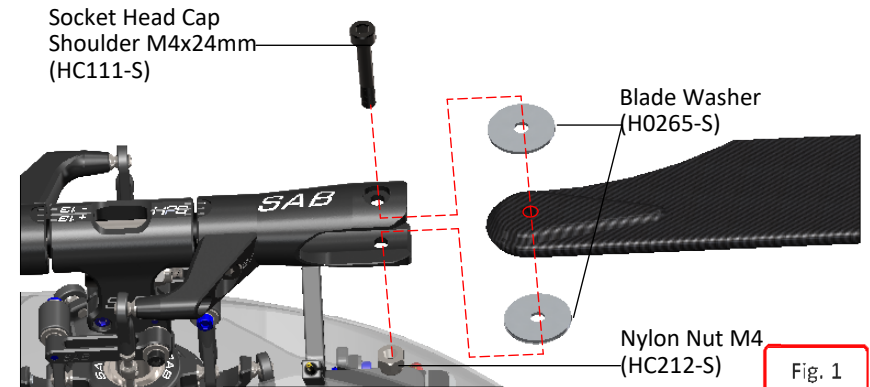

MAINTENANCE

Take a look at the red parts.

Check them frequently. All other parts are not particularly subject to wear.

The lifespan of these components varies according to the type of flying.

On average it is recommended to check these parts every 20 flights. In some instances, based on wear, these parts should be replaced every 100 flights.

Periodically lubricate the tail slider movement and its linkages as well as the swash plate movement and its linkages.

To ensure safety you should do a general inspection of the helicopter after each flight. You should check:

- Proper belt tension (motor belt and tail belt).
- Proper isolation of the wires from the carbon and aluminum parts.
- All screws and bolts remain tight.



IMPORTANT: It is recommended to replace the 3 nylon screws after any crash, even if it is a soft crash.

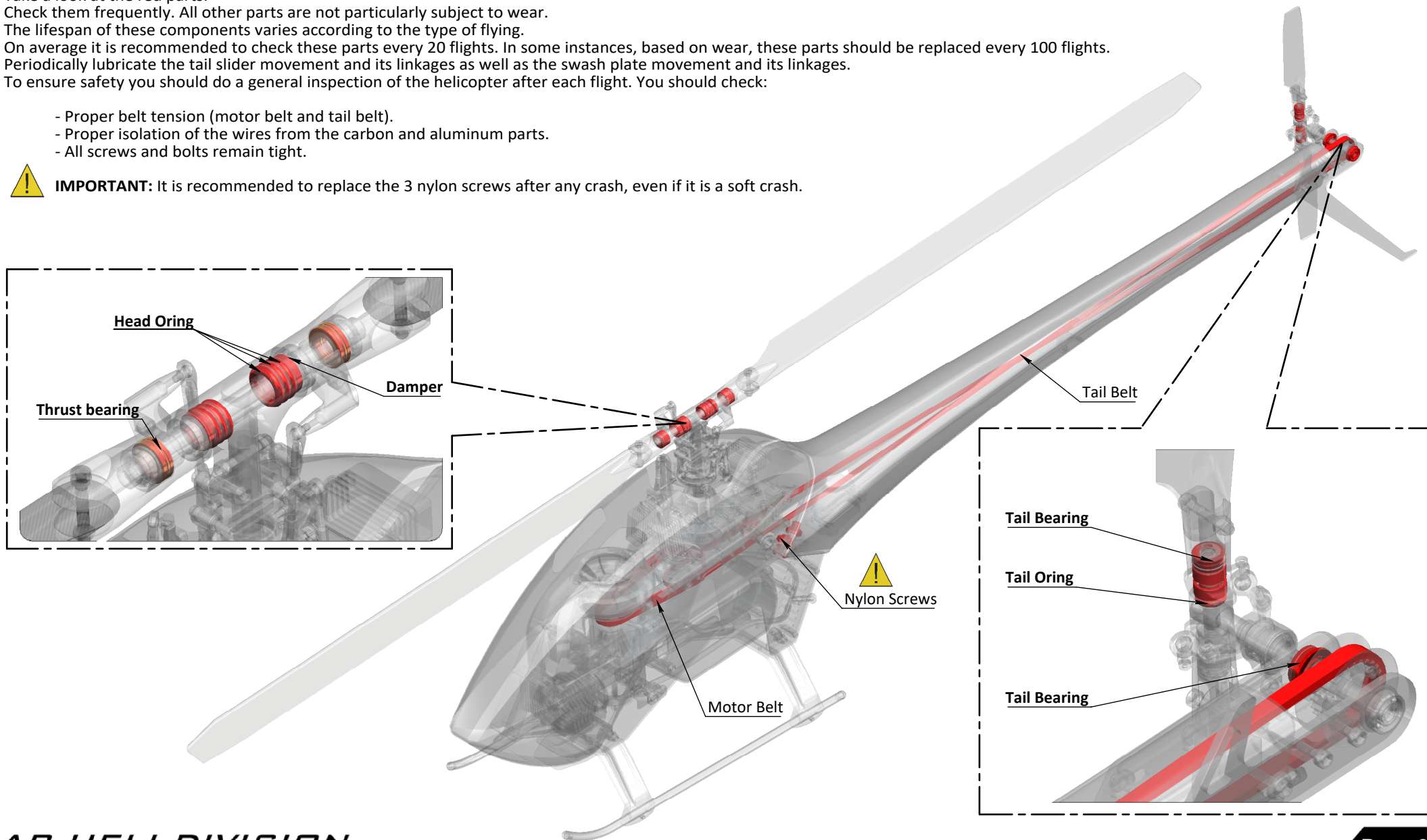

1 Check the dampening on the main and tail rotor to be the same as always.

2 Tighten the main blades before flight.

3 Check main hub screws (M4x22 and 2xM2.5x12). Ensure they are tight.

4 Check Fuel Line (Good connection).

5 Check Tail & Motor belt tension. The tension has to be tight.

6 Check the 4 M3x10 Tail group screws. Ensure they are tight.

7 Check the Main Linkages & Servo Linkages

8 Check tail pulley set screws: Ensure they are tight. (It is suggested use a bit of Green Loctite.)

9 Check for vertical play of the main shaft.

10 Check if the FBL-RX connectors are OK (hot glue is recommended).

11 Check the M2.5x18 bell crank: Belt crank movement must be smooth and the screw fully tightened. (It is suggested use a bit of Green Loctite.)

12 Be sure the following parts are properly lubricated

- *Main shaft/swashplate
- *Tail slider/tail shaft
- *Carbon rod/carbon rod support
- *All thrust bearings
- *All plastic ball connections

TRANSMISSION MODULE

The transmission module is supplied assembled and verified, ready to be used.

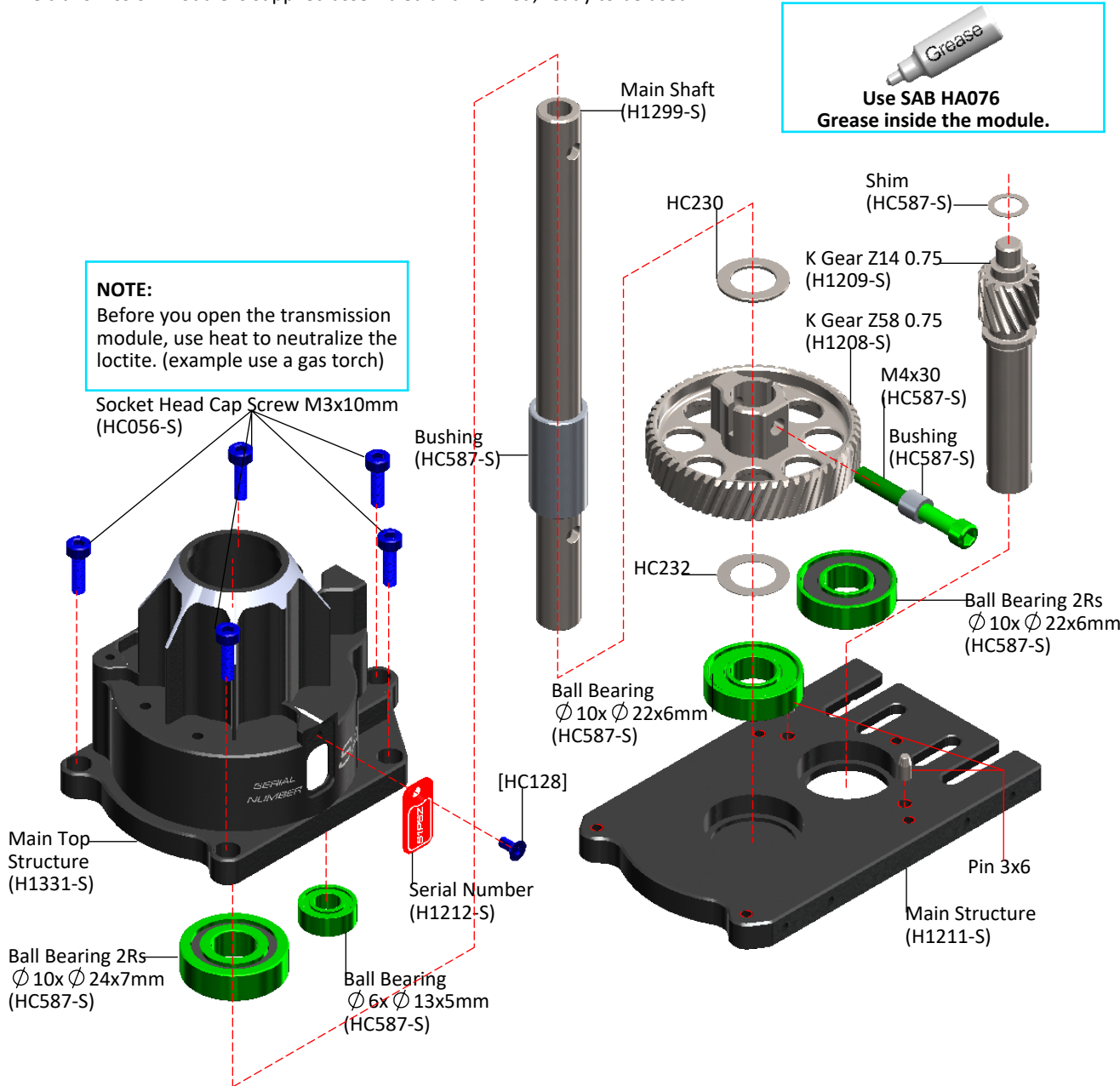

MAIN SHAFT REPLACEMENT





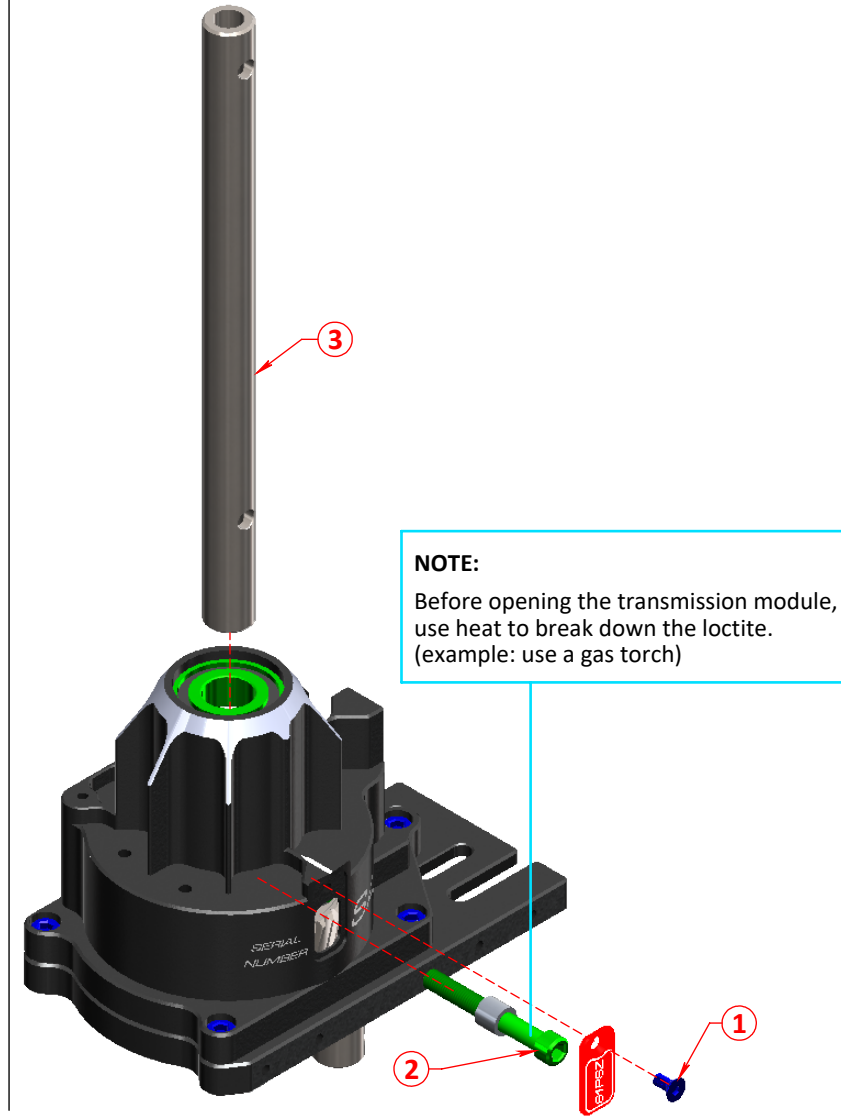





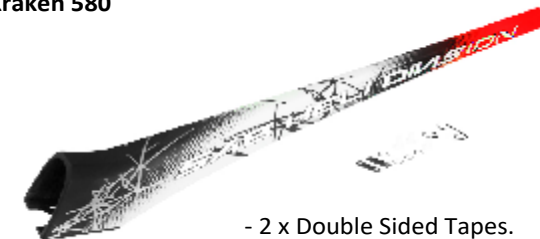

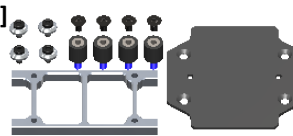
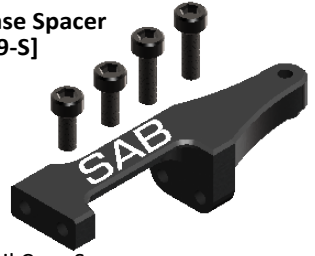

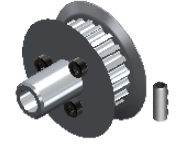
For replacing the main shaft:

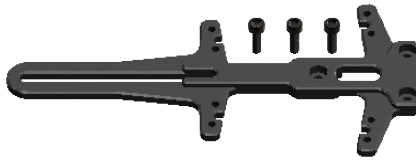
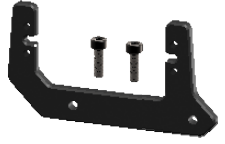
- *Remove the serial number plate
- *Remove the **M4** screw
- *Remove and replace the main shaft
- *Screw in the **M4** screw, with high force and using green loctite

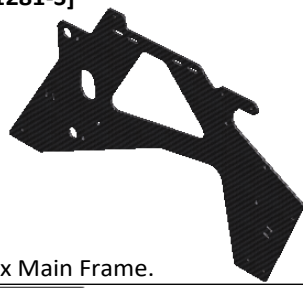

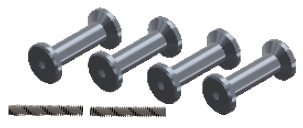

















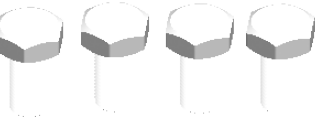
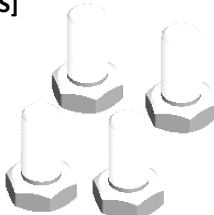
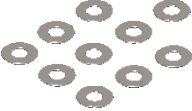

<p>Finishing Washer M3 [H0007-S]</p>  <p>- 10 x Finishing Washers M3.</p>	<p>Tail Servo Lock [H0040-S]</p>  <p>- 2 x Tail Servo Locks. - 2 x Servo Spacers. - 4 x Head Cap Screws M2.5x12mm.</p>	<p>Uniball M2 5H6 [H0064-S]</p>  <p>- 5 x Uniballs M2 5H6. - 5 x Uniball Spacers. - 5 x Head Cap Screws M2x8mm. - 5 x Head Cap Screws M2x6mm.</p>	<p>Uniball M3x4 5H3 [H0065-S]</p>  <p>- 5 x Uniballs M3x4 5H3.5.</p>	<p>Plastic Ball Link [H0066-S]</p>  <p>- 10 x Plastic Ball Link.</p>
<p>Servo Spacer [H0075-S]</p>  <p>- 10 x Servo Spacers.</p>	<p>Radius Arm HPS [H0204BM-S]</p>  <p>- 2 x Radius Arm. - 2 x Spacer Arm 2.5x4x6.3. - 2 x Spacer Arm 2.5x4x3mm. - 2 x Uniball Radius Arm. - 8 x Flanged Bearing Ø 2.5x Ø 6x2.5. - 2 x Washer 2.5x4x0.3mm. - 2 x Socket Head Cap Screw M2.5x15. - 2 x Socket Head Cap Screw M2.5x18.</p>	<p>Radius Plastic Arm [H0205-S]</p>  <p>- 2 x Radius Plastic Arm.</p>	<p>Main Spindle [H0213-S]</p>  <p>- 1 x Tail Spindle. - 2 x Button Cap Screws M6x10mm. - 2 x Washer.</p>	<p>Tail Spindle [H0220-S]</p>  <p>- 1 x Tail Spindle. - 2 x Socket Cap Screws M3x6mm.</p>
<p>Tail Spindle [H0227-S]</p>  <p>- 1 x Tail Shaft. - 1 x Tail Hub. - 1 x Set Screws M3x8mm.</p>	<p>Main Linkage [H0237-S]</p>  <p>- 2 x Main Linkage. - 4 x Plastic Uniball.</p>	<p>Locking Element Tail [H0249-S]</p>  <p>- 2 x Locking Element Tail. - 4 x Socket Head Cap M3x10mm. - 4 x Finishing Washer M3. - 4 x Nylon Nut M3. - 2 x Double Side Tape.</p>	<p>Finishing Washer M2.5 [H0255-S]</p>  <p>- 10 x Finishing Washer M2.5.</p>	<p>Plastic Tail Linkage [H0261-S]</p>  <p>- 2 x Plastic Tail Linkage. - 2 x Grip Link Bushing. - 2 x Head Cap Screws M2x6mm.</p>
<p>Uniball M2 [H0538-S]</p>  <p>- 5 x Uniball M2.</p>	<p>Clutch [H0670-S]</p>  <p>- 1 x Steel Clutch. - 2 x Button Head Socket Cap M4x8.</p>	<p>Fan [H0671-S]</p>  <p>- 1 x Fan. - 4 x Flat Head Socket Cap M3x8mm.</p>	<p>Clutch Support [H0672-S]</p>  <p>- 1 x Clutch Support.</p>	<p>Clutch Bell [H0674-S]</p>  <p>- 1 x Clutch Bell. - 2 x Cluth Line.</p>

<p>Pulley Z26-Z28 [H0675-26-27-28-S]</p>  <ul style="list-style-type: none"> - 1 x Pulley Z26-Z28 - 3 x Radial Bearing 12x18x4mm. - 1 x Pulley Washer. 	<p>Engine Frame Spacer [H0678-S]</p>  <ul style="list-style-type: none"> - 4 x Engine Frame Spacer - 4 x Buttom Head Cap Screw M3x6. 	<p>SAB Fuel Clunk [H0705-S]</p>  <ul style="list-style-type: none"> - 1 x SAB Fuel Clunk. - 2 x SAB Fuel Clunk Filter. - 1 x SAB Fuel Tube 2,5x4,5 - 8,5cm. 	<p>SAB Fuel Nipple [H0708-S]</p>  <ul style="list-style-type: none"> - 1 x SAB Fuel Nipple. - 2 x SAB Tank Grommet. 	<p>SAB Fuel Stop [H0715-S]</p>  <ul style="list-style-type: none"> - 2 x SAB Fuel Stop. - 2 x SAB T connector.
<p>Reference Pin [H1048-S]</p>  <ul style="list-style-type: none"> - 1 x Reference Pin. 	<p>Quick Release Canopy [H1101-S]</p>  <ul style="list-style-type: none"> - 2 x Quick Release Canopy. - 2 x Socket Head Cap Screw M3x6. 	<p>Wire Cover [H1107-S]</p>  <ul style="list-style-type: none"> - 1 x Wire Cover. - 1 x Finishing Washer M3. - 1 x Head Cap Screws M3x8mm. - 2 x Buttom Cap Screws M2.5x6mm. 	<p>Center Hub [H1200-S]</p>  <ul style="list-style-type: none"> - 1 x Center Hub. - 1 x Socket Head Cap M4x20mm. - 2 x Socket Head Cap M2.5x12mm. - 1 x Nylon Nut M4. 	
<p>Swashplate [H1204-S]</p>  <ul style="list-style-type: none"> - 1 x Swashplate Assembly. - 7 x Uniball M3. - 1 x Reference Pin. 	<p>Rear Servo Support [H1206-S]</p>  <ul style="list-style-type: none"> - 1 x Rear Servo Support. - 2 x Socket Head Cap M3x8mm. 	<p>Main Pulley [H1213-S]</p>  <ul style="list-style-type: none"> - 1 x Main Pulley 50T. - 1 x One Way Bearing $\phi 10x \phi 14x12$. - 2 x Ball Bearing $\phi 10x \phi 15x4$mm. - 1 x Bushing $\phi 10x \phi 13x1.5$. 	<p>Front Tail Pulley [H1214-S]</p>  <ul style="list-style-type: none"> - 1 x Front Tail Pulley. - 1 x Socket Head Cap Shoulder M3x18mm. 	<p>Damper [H1216-S]</p>  <ul style="list-style-type: none"> - 2 x Damper A. - 2 x Damper B. - 2 x Damper C. - 4 x Oring 70°. - 4 x Oring 90°.
<p>Boom Connexion [H1224-S]</p>  <ul style="list-style-type: none"> - 1 x Boom Connexion. - 4 x Head Cap Screws M3x10mm. - 4 x Shim $\phi 8x \phi 14x0.2$mm. 	<p>Plastic Landing Gear Support [H1226-S]</p>  <ul style="list-style-type: none"> - 1 x Plastic Landing Gear Support. - 2 x Set Screws M4x4mm. 	<p>Canopy Front Block [H1227-S]</p>  <ul style="list-style-type: none"> - 1 x Canopy Front Block. - 4 x Self Tapping Screws M3x10mm. 	<p>Main Blade Grips [H1368-S]</p>  <ul style="list-style-type: none"> - 2 x Blade Grip. - 2 x Thrust Bearing $\phi 8x \phi 14x4$mm. - 4 x Bearing $\phi 8x \phi 14x4$mm. - 2 x Washer $\phi 11x \phi 13.5x0.5$mm. - 2 x Socket Head Cap M4x10mm. 	

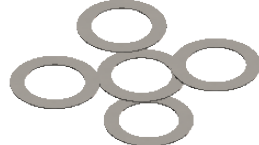
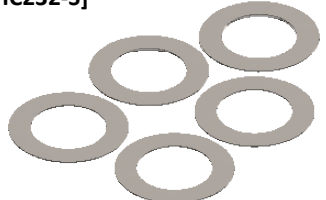
<p>Canopy Kraken 580 [H1381-S]</p>  <ul style="list-style-type: none"> - 1 x Canopy Kraken 580. - 2 x Canopy Grommet. 	<p>Tail Boom Kraken 580 [H1382-S]</p>  <ul style="list-style-type: none"> - 1 x Tail Boom Kraken 580. - 2 x Locking Element Tail. - 4 x Metric Hex Nylon Nuts M3. 	<p>Tail Blade Grips [H1233-S]</p>  <ul style="list-style-type: none"> - 2 x Tail Blade Grip. - 4 x Bearing $\phi 4x \phi 9x2.5mm$. - 2 x Spacer $\phi 7x \phi 9x0.5mm$. - 2 x Thrust Bearing $\phi 4x \phi 9x4mm$. - 2 x Socket Head Cap Screw M3x6mm. - 2 x Socket Head Cap Screw M2x6mm. 		<p>Tail Fin [H1243-S]</p>  <ul style="list-style-type: none"> - 1 x Tail Fin. - 1 x Orange Stickers. - 1 x Green Stickers. - 1 x Yellow Stickers. - 1 x White Stickers. - 1 x Red Stickers. 	
<p>FBL Support [H1237-S]</p>  <ul style="list-style-type: none"> - 1 x Alu FBL Support. - 1 x FBL Plate Mount. - 4 x Head Cap Screws M2.5x8. - 4 x Finishing Washer M2.5. - 4 x Flat Screws M3x5mm. - 4 x Rubber Column. 	<p>Tail Case Spacer [H1239-S]</p>  <ul style="list-style-type: none"> - 1 x Tail Case Spacer. - 2 x Head Cap Screws M2.5x6mm. - 2 x Head Cap Screws M2.5x8mm. 	<p>Tail Side Plate [H1240-S]</p>  <ul style="list-style-type: none"> - 1 x Tail Side Plate. - 1 x Flanged Bearing $\phi 5x \phi 13x4mm$ 	<p>Landing Gear Rod [H1242-S]</p>  <ul style="list-style-type: none"> - 2 x Landing Gear Rod. - 4 x Plug. 	<p>Tail Pulley [H1272-S]</p>  <ul style="list-style-type: none"> - 1 x Tail Pulley 23T. - 1 x Set Screw M3x8mm. - 4 x Head Cap Screws M2x12mm. 	
<p>Tail Bell Crank Lever [H1248-S]</p>  <ul style="list-style-type: none"> - 1 x Bell Crank Lever Assembled. - 1 x Head Cap Screws M2.5x18mm. - 1 x Head Cap Screws M2x6mm. - 1 x Uniball M2. - 1 x Uniball M3. 	<p>Tail Pitch Slider [H1249-S]</p>  <ul style="list-style-type: none"> - 1 x Tail Pitch Slider Assembled. 	<p>Front Servo Mount 35mm [H1261-S]</p>  <ul style="list-style-type: none"> - 1 x Front Servo Mount 35mm. - 3 x Head Cap Screws M2.5x8mm. 	<p>Rear Servo Mount 35mm [H1262-S]</p>  <ul style="list-style-type: none"> - 1 x Rear Servo Mount 35mm. - 2 x Socket Head Cap M2.5x8mm. 	<p>Engine Support Spacer [H1286-S]</p>  <ul style="list-style-type: none"> - 2 x Engine Support Spacer. - 4 x Flat Head Cap Screw M3x8mm. 	
<p>Main Frame [H1281-S]</p>  <ul style="list-style-type: none"> - 1 x Main Frame. 	<p>Tank [H1282-S]</p>  <ul style="list-style-type: none"> - 1 x Tank. - 4 x Tank Rubber. - 2 x Bushing. 	<p>Tank Column Mount [H1283-S]</p>  <ul style="list-style-type: none"> - 4 x Tank column mount. - 2 x Set Screw M3x20mm. 	<p>Engine Support SX [H1284-S]</p>  <ul style="list-style-type: none"> - 1 x Engine support SX. 	<p>Engine Support DX [H1285-S]</p>  <ul style="list-style-type: none"> - 1 x Engine support DX. 	<p>Engine Support Spacer [H1286-S]</p>  <ul style="list-style-type: none"> - 2 x Engine Support Spacer. - 4 x Flat Head Cap Screw M3x8mm.

<p>Fan Case [H1287-S]</p> <p>- 1 x Fan Case SX. - 1 x Fan Case DX.</p>	<p>Linkage Tail Support [H1315-S]</p> <p>- 1 x Linkage Tail Support. - 2 x Head Cap Screws M2.5x8.</p>	<p>Frame Spacer [H1324-S]</p> <p>- 4 x Frame Spacer.</p>	<p>Blade Grip Arm 27 [H1342-S]</p> <p>- 2 x Blade Grip Arm. - 2 x Head Cap Screw M4x8. - 2 x Uniball M3x4 Ø5 H3.5.</p>	<p>Engine Shaft [H1369-S]</p> <p>- 1 x Engine Shaft. - 2 x Head Cap Screw M3x10.</p>
<p>Frame Spacer [H1380-S]</p> <p>- 1 x CF Xross Plate. - 4 x Alu Xross Mount. - 8 x Flat Head Cap Screw M2.5x5.</p>	<p>CF Wire Support [H1383-S]</p> <p>- 1 x CF Wire Support. - 2 x Finishing Washer M2.5. - 2 x Head Cap Screw M2.5x8.</p>	<p>[HC004-S]</p> <p>- 8 x Head Cap Screws M2x6mm.</p>	<p>[HC008-S]</p> <p>- 8 x Head Cap Screws M2x8mm.</p>	<p>[HC018-S]</p> <p>- 8 x Head Cap Screws M2.5x6mm.</p>
<p>[HC019-S]</p> <p>- 8 x Button Special Screws M2.5x6.</p>	<p>[HC020-S]</p> <p>- 8 x Head Cap Screws M2.5x8mm.</p>	<p>[HC022-S]</p> <p>- 8 x Head Cap Screws M2.5x10mm.</p>	<p>[HC026-S]</p> <p>- 8 x Head Cap Screws M2.5x12mm.</p>	<p>[HC028-S]</p> <p>- 8 x Head Cap Screws M2.5x15mm.</p>
<p>[HC032-S]</p> <p>- 5 x Head Cap Screws M2.5x18mm.</p>	<p>[HC044-S]</p> <p>- 5 x Head Cap Screws M3x6mm.</p>	<p>[HC050-S]</p> <p>- 8 x Head Cap Screws M3x8mm.</p>	<p>[HC056-S]</p> <p>- 8 x Head Cap Screws M3x10mm.</p>	<p>[HC068-S]</p> <p>- 8 x Head Cap Screws M3x16mm.</p>
<p>[HC074-S]</p> <p>- 2 x Head Cap Shoulder M3x16mm. - 2 x Nylon Nut M3.</p>	<p>[HC079-S]</p> <p>- 2 x Head Cap Shoulder M3x18mm. - 2 x Nylon Nut M3.</p>	<p>[HC094-S]</p> <p>- 8 x Button Cap Screws M3x6mm.</p>	<p>[HC098-S]</p> <p>- 8 x Button Cap Screws M4x8mm.</p>	<p>[HC102-S]</p> <p>- 8 x Head Cap Screws M4x10mm.</p>

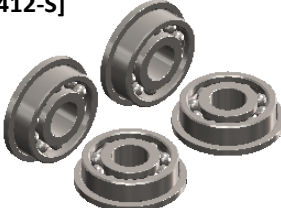
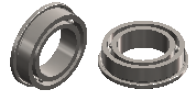
<p>[HC111-S]</p>  <p>- 8 x Head Cap Shoulder M4x24mm.</p>	<p>[HC122-S]</p>  <p>- 8 x Button Cap Screws M6x10mm.</p>	<p>[HC128-S]</p>  <p>- 8 x Flat Cap Screws M2.5x5mm.</p>	<p>[HC132-S]</p>  <p>- 8 x Flat Cap Screws M3x5mm.</p>	<p>[HC134-S]</p>  <p>- 8 x Flat Cap Screws M3x8mm.</p>
<p>[HC136-S]</p>  <p>- 8 x Self Tapping Screws M3x10mm.</p>	<p>[HC140-S]</p>  <p>- 8 x Set Screws M2.5x18mm.</p>	<p>[HC144-S]</p>  <p>- 8 x Set Screws M3x6mm.</p>	<p>[HC150-S]</p>  <p>- 8 x Set Screws M3x20mm.</p>	<p>[HC152-S]</p>  <p>- 8 x Set Screws M4x4mm.</p>
<p>[HC164-S]</p>  <p>- 4 x Bolt M6x14mm.</p>	<p>[HC165-S]</p>  <p>- 4 x Bolt M6x20mm.</p>	<p>[HC170-S]</p>  <p>- 10 x Washer $\varnothing 2,2x \varnothing 5x0,3mm$.</p>	<p>[HC181-S]</p>  <p>- 4 x Washer $\varnothing 3x \varnothing 7x1mm$.</p>	<p>[HC193-S]</p>  <p>- 5 x Washer $\varnothing 6x \varnothing 12x1mm$.</p>
<p>[HC206-S]</p>  <p>- 8 x Metrix Nylon Nut M3.</p>	<p>[HC212-S]</p>  <p>- 8 x Metrix Nylon Nut M4.</p>	<p>[HC224-S]</p>  <p>- 4 x Nut M8.</p>	<p>[HC228-S]</p>  <p>- 5 x Shim $\varnothing 8x \varnothing 14x0.2mm$.</p>	<p>[HC232-S]</p>  <p>- 5 x Shim $\varnothing 8x \varnothing 14x0.2mm$.</p>
<p>[HC242-S]</p>  <p>- 3 x Thread Rod M2.5x40.</p>	<p>[HC400-S]</p>  <p>- 4 x Flanged Bearing $\varnothing 2.5x \varnothing 6x2.6$.</p>	<p>[HC403-S]</p>  <p>- 4 x Ball Bearing $\varnothing 4x \varnothing 9x2.5mm$.</p>	<p>[HC412-S]</p>  <p>- 4 x Flanged Bearing $\varnothing 5x \varnothing 13x4mm$.</p>	<p>[HC416-S]</p>  <p>- 2 x Flanged Bearing $\varnothing 7x \varnothing 11x2.5$.</p>

<p>[HC417-S]</p>  <p>- 2 x Ball Bearing Ø 8x Ø 14x4mm.</p>	<p>[HC420-S]</p>  <p>- 4 x Ball Bearing Ø 10x Ø 15x4mm.</p>	<p>[HC425-S]</p>  <p>- 2 x Radial bearing Ø 12x Ø 18x4mm.</p>	<p>[HC430-S]</p>  <p>- 2 x Rad Bearing Ø 30x Ø 37x4mm.</p>	<p>[HC434-S]</p>  <p>- 2 x Thrust Bearing Ø 4x Ø 9x4mm.</p>	<p>[HC437-S]</p>  <p>- 2 x Thrust Bearing Ø 10x Ø 14x4mm.</p>	<p>[HC544-S]</p>  <p>- 8 x Head Cap Screw M4x20.</p>
<p>[HC549-S]</p>  <p>- 8 x Tapping Screw M3x12mm.</p>	<p>[HC582-S]</p>  <p>- 8 x Head Screw Special M4x8.</p>	<p>[HC586-S]</p>  <p>- 1 x Carbon Rod Ø 2.5x Ø 4x570. - 2 x Plastic Ball Linkage. - 2 x Thread Rod M2.5x40. - 2 x Aluminum Bush.</p>	<p>[HC587-S]</p>  <p>- 1 x Ball Bearing Ø10xØ24x7mm. - 1 x Ball Bearing 10 x 22 x 6 mm. - 1 x Ball Bearing 2RSØ10xØ22x6. - 1 x Ball Bearing Ø6xØ13x5mm. - 1 x Wave Washer Ø10xØ15x0.3 - 2 x Pin 3x6mm. - 1 x Head Cap Shoulder M4x30. - 1 x Bushing. - 1 x Shim Ø6xØ9x0.2mm.</p>	<p>[HC600-S]</p>  <p>- 1 x Motor Belt GT3-288-13 mm.</p>		
<p>[HC592-S]</p>  <p>- 1 x Tail Belt 1722mm HTD3.</p>	<p>[HC594-S]</p>  <p>- 2 x Spacer Ø7xØ9x0,5. - 2 x Grip Link Bushing. - 2 x Spacer Ø4xØ6,9x0,5. - 2 x Spacer Ø8xØ12,5x0,5. - 2 x Spacer Ø11xØ13,8x0,5. - 2 x Spacer Arm Ø2,5xØ4x6,3. - 2 x Oring 90°.</p>	<p>[HC594-S]</p>  <p>- 2 x Spacer Arm Ø2,5xØ4x3mm. - 2 x Washer Ø2,5xØ4x0,3mm. - 2 x Washer Ø4.1xØ6x0.1mm. - 2 x Spring Washer Ø10xØ15x0.3. - 2 x Washer Ø8xØ14x0.2mm.</p>	<p>[HA010-S]</p>  <p>- 2 x Cable Pass.</p>	<p>[HA021-S]</p>  <p>- 2 x Canopy Grommet.</p>	<p>[HA035-S]</p>  <p>- 2 x Double side tape 30x100x1.</p>	
<p>[HA044-S]</p>  <p>- 2 x Strap 16x205mm.</p>	<p>[HA050-S]</p>  <p>- 4 x Futaba servo arm.</p>	<p>[HA051-S]</p>  <p>- 4 x JR servo arm.</p>	<p>[HA075-S]</p>  <p>- 1 x Free Wheel Clutches grease.</p>	<p>[HA076-S]</p>  <p>- 1 x Tranmissions module grease.</p>	<p>[HA078-S]</p>  <p>- 1 x Foam Blade Holder 580.</p>	
<p>MAIN BLADES 570 WHITE (BW0570)</p>  <p>- 2 x Main Blades 570 White.</p>				<p>TAIL BLADES 95 WHITE (BW5095)</p>  <p>- 2 x Tail Blades 95 White.</p>		



Carefully check your model before each flight to ensure it is airworthy.

Consider flying only in areas dedicated to the use of model helicopters.

Check and inspect the flying area to ensure it is clear of people and obstacles.

Rotor blades can rotate at very high speeds! Be aware of the danger they pose.

Always keep the model at a safe distance from other pilots and spectators.

Avoid maneuvers with trajectories towards a crowd.

Always maintain a safe distance from the model.

GOBLIN KRAKEN NITRO 580

Release 1.0 - August 2020

WORLD DISTRIBUTION

www.goblin-helicopter.com

For sales inquiries, please email:

sales@goblin-helicopter.com

For info inquiries, please email:

support@goblin-helicopter.com

Attention: If you are a customer and have questions or need of assistance, please contact in a first time the Goblin retailer where you made the purchase.

EUROPEAN DISTRIBUTION

www.sabitaly.it

For sales inquiries, please email:

sales@sabitaly.it

For info inquiries, please email:

support@sabitaly.it

Attention: If you are a customer and have questions or need of assistance, please contact in a first time the Goblin retailer where you made the purchase.

WWW.GOBLIN-HELICOPTER.COM



SAB HELI DIVISION

SAB